

CHAPTER – 23 HEAT AND TEMPERATURE EXERCISES

1. Ice point = 20° (L_0) $L_1 = 32^\circ$
Steam point = 80° (L_{100})

$$T = \frac{L_1 - L_0}{L_{100} - L_0} \times 100 = \frac{32 - 20}{80 - 20} \times 100 = 20^\circ\text{C}$$

2. $P_{tr} = 1.500 \times 10^4$ Pa
 $P = 2.050 \times 10^4$ Pa

We know, For constant volume gas Thermometer

$$T = \frac{P}{P_{tr}} \times 273.16 \text{ K} = \frac{2.050 \times 10^4}{1.500 \times 10^4} \times 273.16 = 373.31$$

3. Pressure Measured at M.P = $2.2 \times$ Pressure at Triple Point

$$T = \frac{P}{P_{tr}} \times 273.16 = \frac{2.2 \times P_{tr}}{P_{tr}} \times 273.16 = 600.952 \text{ K} \approx 601 \text{ K}$$

4. $P_{tr} = 40 \times 10^3$ Pa, $P = ?$

$$T = 100^\circ\text{C} = 373 \text{ K}, \quad T = \frac{P}{P_{tr}} \times 273.16 \text{ K}$$

$$\Rightarrow P = \frac{T \times P_{tr}}{273.16} = \frac{373 \times 40 \times 10^3}{273.16} = 54620 \text{ Pa} = 5.42 \times 10^3 \text{ Pa} \approx 5.42 \text{ K Pa}$$

5. $P_1 = 70 \text{ K Pa}$, $P_2 = ?$
 $T_1 = 273 \text{ K}$, $T_2 = 373 \text{ K}$

$$T = \frac{P_1}{P_{tr}} \times 273.16 \quad \Rightarrow 273 = \frac{70 \times 10^3}{P_{tr}} \times 273.16 \quad \Rightarrow P_{tr} = \frac{70 \times 273.16 \times 10^3}{273}$$

$$T_2 = \frac{P_2}{P_{tr}} \times 273.16 \quad \Rightarrow 373 = \frac{P_2 \times 273}{70 \times 273.16 \times 10^3} \quad \Rightarrow P_2 = \frac{373 \times 70 \times 10^3}{273} = 95.6 \text{ K Pa}$$

6. $P_{\text{ice point}} = P_{0^\circ} = 80 \text{ cm of Hg}$
 $P_{\text{steam point}} = P_{100^\circ} = 90 \text{ cm of Hg}$
 $P_0 = 100 \text{ cm}$

$$t = \frac{P - P_0}{P_{100} - P_0} \times 100^\circ = \frac{80 - 100}{90 - 100} \times 100 = 200^\circ\text{C}$$

7. $T' = \frac{V}{V - V'} T_0$ $T_0 = 273$,

$$V = 1800 \text{ CC}, \quad V' = 200 \text{ CC}$$

$$T' = \frac{1800}{1600} \times 273 = 307.125 \approx 307$$

8. $R_t = 86\Omega$; $R_{0^\circ} = 80\Omega$; $R_{100^\circ} = 90\Omega$

$$t = \frac{R_t - R_0}{R_{100} - R_0} \times 100 = \frac{86 - 80}{90 - 80} \times 100 = 60^\circ\text{C}$$

9. R at ice point (R_0) = 20Ω
 R at steam point (R_{100}) = 27.5Ω
 R at Zinc point (R_{420}) = 50Ω
 $R_\theta = R_0 (1 + \alpha\theta + \beta\theta^2)$
 $\Rightarrow R_{100} = R_0 + R_0 \alpha\theta + R_0 \beta\theta^2$
 $\Rightarrow \frac{R_{100} - R_0}{R_0} = \alpha\theta + \beta\theta^2$

$$\Rightarrow \frac{27.5 - 20}{20} = \alpha \times 100 + \beta \times 10000$$

$$\Rightarrow \frac{7.5}{20} = 100 \alpha + 10000 \beta$$

$$R_{420} = R_0 (1 + \alpha\theta + \beta\theta^2) \Rightarrow \frac{50 - R_0}{R_0} = \alpha\theta + \beta\theta^2$$

$$\Rightarrow \frac{50 - 20}{20} = 420 \times \alpha + 176400 \times \beta \quad \Rightarrow \frac{3}{2} = 420 \alpha + 176400 \beta$$

$$\Rightarrow \frac{7.5}{20} = 100 \alpha + 10000 \beta \quad \Rightarrow \frac{3}{2} = 420 \alpha + 176400 \beta$$

10. $L_1 = ?$, $L_0 = 10 \text{ m}$, $\alpha = 1 \times 10^{-5}/^\circ\text{C}$, $t = 35$

$$L_1 = L_0 (1 + \alpha t) = 10(1 + 10^{-5} \times 35) = 10 + 35 \times 10^{-4} = 10.0035 \text{ m}$$

11. $t_1 = 20^\circ\text{C}$, $t_2 = 10^\circ\text{C}$, $L_1 = 1 \text{ cm} = 0.01 \text{ m}$, $L_2 = ?$

$$\alpha_{\text{steel}} = 1.1 \times 10^{-5}/^\circ\text{C}$$

$$L_2 = L_1 (1 + \alpha_{\text{steel}} \Delta T) = 0.01(1 + 101 \times 10^{-5} \times 10) = 0.01 + 0.01 \times 1.1 \times 10^{-4}$$

$$= 10^{-4} \times 10^{-6} + 1.1 \times 10^{-6} = 10^{-6} (10000 + 1.1) = 10001.1$$

$$= 1.00011 \times 10^{-2} \text{ m} = 1.00011 \text{ cm}$$

12. $L_0 = 12 \text{ cm}$, $\alpha = 11 \times 10^{-5}/^\circ\text{C}$

$$t_w = 18^\circ\text{C} \quad t_s = 48^\circ\text{C}$$

$$L_w = L_0 (1 + \alpha t_w) = 12 (1 + 11 \times 10^{-5} \times 18) = 12.002376 \text{ m}$$

$$L_s = L_0 (1 + \alpha t_s) = 12 (1 + 11 \times 10^{-5} \times 48) = 12.006336 \text{ m}$$

$$\Delta L = 12.006336 - 12.002376 = 0.00396 \text{ m} \approx 0.4 \text{ cm}$$

13. $d_1 = 2 \text{ cm} = 2 \times 10^{-2}$

$$t_1 = 0^\circ\text{C}, \quad t_2 = 100^\circ\text{C}$$

$$\alpha_{\text{al}} = 2.3 \times 10^{-5}/^\circ\text{C}$$

$$d_2 = d_1 (1 + \alpha \Delta t) = 2 \times 10^{-2} (1 + 2.3 \times 10^{-5} \times 100)$$

$$= 0.02 + 0.000046 = 0.020046 \text{ m} = 2.0046 \text{ cm}$$

14. $L_{\text{st}} = L_{\text{Al}}$ at 20°C $\alpha_{\text{Al}} = 2.3 \times 10^{-5}/^\circ\text{C}$

$$\text{So, } L_{\text{st}} (1 - \alpha_{\text{st}} \times 20) = L_{\text{Al}} (1 - \alpha_{\text{Al}} \times 20) \quad \alpha_{\text{st}} = 1.1 \times 10^{-5}/^\circ\text{C}$$

$$(a) \Rightarrow \frac{L_{\text{st}}}{L_{\text{Al}}} = \frac{(1 - \alpha_{\text{Al}} \times 20)}{(1 - \alpha_{\text{st}} \times 20)} = \frac{1 - 2.3 \times 10^{-5} \times 20}{1 - 1.1 \times 10^{-5} \times 20} = \frac{0.99954}{0.99978} = 0.999$$

$$(b) \Rightarrow \frac{L_{\text{40st}}}{L_{\text{40Al}}} = \frac{(1 - \alpha_{\text{Al}} \times 40)}{(1 - \alpha_{\text{st}} \times 40)} = \frac{1 - 2.3 \times 10^{-5} \times 40}{1 - 1.1 \times 10^{-5} \times 40} = \frac{0.99954}{0.99978} = 0.999$$

$$= \frac{L_{\text{Al}}}{L_{\text{st}}} \times \frac{1 + 2.3 \times 10^{-5} \times 10}{273} = \frac{0.99977 \times 1.00092}{1.00044} = 1.0002496 \approx 1.00025$$

$$\frac{L_{\text{100Al}}}{L_{\text{100St}}} = \frac{(1 + \alpha_{\text{Al}} \times 100)}{(1 + \alpha_{\text{st}} \times 100)} = \frac{0.99977 \times 1.00092}{1.00011} = 1.00096$$

15. (a) Length at $16^\circ\text{C} = L$

$$L = ? \quad T_1 = 16^\circ\text{C}, \quad T_2 = 46^\circ\text{C}$$

$$\alpha = 1.1 \times 10^{-5}/^\circ\text{C}$$

$$\Delta L = L \alpha \Delta \theta = L \times 1.1 \times 10^{-5} \times 30$$

$$\% \text{ of error} = \left(\frac{\Delta L}{L} \times 100 \right) \% = \left(\frac{L \alpha \Delta \theta}{L} \times 100 \right) \% = 1.1 \times 10^{-5} \times 30 \times 100 \% = 0.033 \%$$

(b) $T_2 = 6^\circ\text{C}$

$$\% \text{ of error} = \left(\frac{\Delta L}{L} \times 100 \right) \% = \left(\frac{L \alpha \Delta \theta}{L} \times 100 \right) \% = -1.1 \times 10^{-5} \times 10 \times 100 = -0.011 \%$$

16. $T_1 = 20^\circ\text{C}$, $\Delta L = 0.055\text{mm} = 0.55 \times 10^{-3}\text{ m}$
 $t_2 = ?$ $\alpha_{\text{st}} = 11 \times 10^{-6}/^\circ\text{C}$

We know,
 $\Delta L = L_0 \alpha \Delta T$

In our case,
 $0.055 \times 10^{-3} = 1 \times 11 \times 10^{-6} \times (T_1 + T_2)$
 $0.055 = 11 \times 10^{-3} \times 20 \pm 11 \times 10^{-3} \times T_2$
 $T_2 = 20 + 5 = 25^\circ\text{C}$ or $20 - 5 = 15^\circ\text{C}$
 The expt. Can be performed from 15 to 25°C

17. $f_{0^\circ\text{C}} = 0.998\text{ g/m}^3$, $f_{4^\circ\text{C}} = 1\text{ g/m}^3$
 $f_{0^\circ\text{C}} = \frac{f_{4^\circ\text{C}}}{1 + \gamma \Delta T} \Rightarrow 0.998 = \frac{1}{1 + \gamma \times 4} \Rightarrow 1 + 4\gamma = \frac{1}{0.998}$
 $\Rightarrow 4 + \gamma = \frac{1}{0.998} - 1 \Rightarrow \gamma = 0.0005 \approx 5 \times 10^{-4}$

As density decreases $\gamma = -5 \times 10^{-4}$

18. Iron rod Aluminium rod
 L_{Fe} L_{Al}
 $\alpha_{\text{Fe}} = 12 \times 10^{-8}/^\circ\text{C}$ $\alpha_{\text{Al}} = 23 \times 10^{-8}/^\circ\text{C}$

Since the difference in length is independent of temp. Hence the different always remains constant.

$L'_{\text{Fe}} = L_{\text{Fe}}(1 + \alpha_{\text{Fe}} \times \Delta T)$... (1)
 $L'_{\text{Al}} = L_{\text{Al}}(1 + \alpha_{\text{Al}} \times \Delta T)$... (2)
 $L'_{\text{Fe}} - L'_{\text{Al}} = L_{\text{Fe}} - L_{\text{Al}} + L_{\text{Fe}} \times \alpha_{\text{Fe}} \times \Delta T - L_{\text{Al}} \times \alpha_{\text{Al}} \times \Delta T$
 $\frac{L_{\text{Fe}}}{L_{\text{Al}}} = \frac{\alpha_{\text{Al}}}{\alpha_{\text{Fe}}} = \frac{23}{12} = 23 : 12$

19. $g_1 = 9.8\text{ m/s}^2$, $g_2 = 9.788\text{ m/s}^2$
 $T_1 = 2\pi \frac{\sqrt{l_1}}{g_1}$ $T_2 = 2\pi \frac{\sqrt{l_2}}{g_2} = 2\pi \frac{\sqrt{l_1(1 + \Delta T)}}{g}$

$\alpha_{\text{Steel}} = 12 \times 10^{-6}/^\circ\text{C}$
 $T_1 = 20^\circ\text{C}$ $T_2 = ?$
 $T_1 = T_2$

$\Rightarrow 2\pi \frac{\sqrt{l_1}}{g_1} = 2\pi \frac{\sqrt{l_1(1 + \Delta T)}}{g_2} \Rightarrow \frac{l_1}{g_1} = \frac{l_1(1 + \Delta T)}{g_2}$
 $\Rightarrow \frac{1}{9.8} = \frac{1 + 12 \times 10^{-6} \times \Delta T}{9.788} \Rightarrow \frac{9.788}{9.8} = 1 + 12 \times 10^{-6} \times \Delta T$
 $\Rightarrow \frac{9.788}{9.8} - 1 = 12 \times 10^{-6} \Delta T \Rightarrow \Delta T = \frac{-0.00122}{12 \times 10^{-6}}$
 $\Rightarrow T_2 - 20 = -101.6 \Rightarrow T_2 = -101.6 + 20 = -81.6 \approx -82^\circ\text{C}$

20. Given
 $d_{\text{st}} = 2.005\text{ cm}$, $d_{\text{Al}} = 2.000\text{ cm}$
 $\alpha_{\text{S}} = 11 \times 10^{-6}/^\circ\text{C}$ $\alpha_{\text{Al}} = 23 \times 10^{-6}/^\circ\text{C}$
 $d's = 2.005(1 + \alpha_{\text{S}} \Delta T)$ (where ΔT is change in temp.)
 $\Rightarrow d's = 2.005 + 2.005 \times 11 \times 10^{-6} \Delta T$
 $d'_{\text{Al}} = 2(1 + \alpha_{\text{Al}} \Delta T) = 2 + 2 \times 23 \times 10^{-6} \Delta T$

The two will slip i.e the steel ball will fall when both the diameters become equal.

So,
 $\Rightarrow 2.005 + 2.005 \times 11 \times 10^{-6} \Delta T = 2 + 2 \times 23 \times 10^{-6} \Delta T$
 $\Rightarrow (46 - 22.055)10^{-6} \times \Delta T = 0.005$
 $\Rightarrow \Delta T = \frac{0.005 \times 10^6}{23.945} = 208.81$

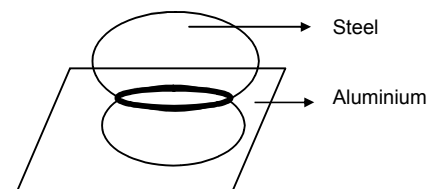

Now $\Delta T = T_2 - T_1 = T_2 - 10^\circ\text{C}$ [$\therefore T_1 = 10^\circ\text{C}$ given]

$$\Rightarrow T_2 = \Delta T + T_1 = 208.81 + 10 = 281.81$$

21. The final length of aluminium should be equal to final length of glass.

Let the initial length of aluminium = l

$$l(1 - \alpha_{Al}\Delta T) = 20(1 - \alpha_g\Delta\theta)$$

$$\Rightarrow l(1 - 24 \times 10^{-6} \times 40) = 20(1 - 9 \times 10^{-6} \times 40)$$

$$\Rightarrow l(1 - 0.00096) = 20(1 - 0.00036)$$

$$\Rightarrow l = \frac{20 \times 0.99964}{0.99904} = 20.012 \text{ cm}$$

Let initial breadth of aluminium = b

$$b(1 - \alpha_{Al}\Delta T) = 30(1 - \alpha_g\Delta\theta)$$

$$\Rightarrow b = \frac{30 \times (1 - 9 \times 10^{-6} \times 40)}{(1 - 24 \times 10^{-6} \times 40)} = \frac{30 \times 0.99964}{0.99904} = 30.018 \text{ cm}$$

22. $V_g = 1000 \text{ CC}$, $T_1 = 20^\circ\text{C}$
 $V_{Hg} = ?$ $\gamma_{Hg} = 1.8 \times 10^{-4} /^\circ\text{C}$
 $\gamma_g = 9 \times 10^{-6} /^\circ\text{C}$

ΔT remains constant

$$\text{Volume of remaining space} = V'_g - V'_{Hg}$$

Now

$$V'_g = V_g(1 + \gamma_g\Delta T) \quad \dots(1)$$

$$V'_{Hg} = V_{Hg}(1 + \gamma_{Hg}\Delta T) \quad \dots(2)$$

Subtracting (2) from (1)

$$V'_g - V'_{Hg} = V_g - V_{Hg} + V_g\gamma_g\Delta T - V_{Hg}\gamma_{Hg}\Delta T$$

$$\Rightarrow \frac{V_g}{V_{Hg}} = \frac{\gamma_{Hg}}{\gamma_g} \Rightarrow \frac{1000}{V_{Hg}} = \frac{1.8 \times 10^{-4}}{9 \times 10^{-6}}$$

$$\Rightarrow V_{HG} = \frac{9 \times 10^{-3}}{1.8 \times 10^{-4}} = 500 \text{ CC.}$$

23. Volume of water = 500 cm^3

$$\text{Area of cross section of can} = 125 \text{ m}^2$$

Final Volume of water

$$= 500(1 + \gamma\Delta\theta) = 500[1 + 3.2 \times 10^{-4} \times (80 - 10)] = 511.2 \text{ cm}^3$$

The aluminium vessel expands in its length only so area expansion of base can be neglected.

$$\text{Increase in volume of water} = 11.2 \text{ cm}^3$$

$$\text{Considering a cylinder of volume} = 11.2 \text{ cm}^3$$

$$\text{Height of water increased} = \frac{11.2}{125} = 0.089 \text{ cm}$$

24. $V_0 = 10 \times 10 \times 10 = 1000 \text{ CC}$

$$\Delta T = 10^\circ\text{C}, \quad V'_{HG} - V'_g = 1.6 \text{ cm}^3$$

$$\alpha_g = 6.5 \times 10^{-6} /^\circ\text{C}, \quad \gamma_{Hg} = ?, \quad \gamma_g = 3 \times 6.5 \times 10^{-6} /^\circ\text{C}$$

$$V'_{Hg} = V_{HG}(1 + \gamma_{Hg}\Delta T) \quad \dots(1)$$

$$V'_g = V_g(1 + \gamma_g\Delta T) \quad \dots(2)$$

$$V'_{Hg} - V'_g = V_{HG} - V_g + V_{HG}\gamma_{Hg}\Delta T - V_g\gamma_g\Delta T$$

$$\Rightarrow 1.6 = 1000 \times \gamma_{Hg} \times 10 - 1000 \times 6.5 \times 3 \times 10^{-6} \times 10$$

$$\Rightarrow \gamma_{Hg} = \frac{1.6 + 6.3 \times 3 \times 10^{-2}}{10000} = 1.789 \times 10^{-4} \approx 1.8 \times 10^{-4} /^\circ\text{C}$$

25. $f_w = 880 \text{ Kg/m}^3$, $f_b = 900 \text{ Kg/m}^3$
 $T_1 = 0^\circ\text{C}$, $\gamma_w = 1.2 \times 10^{-3} /^\circ\text{C}$,
 $\gamma_b = 1.5 \times 10^{-3} /^\circ\text{C}$

The sphere begins to sink when,

$$(mg)_{\text{sphere}} = \text{displaced water}$$

$$\Rightarrow Vf'_w g = Vf'_b g$$

$$\Rightarrow \frac{f_w}{1 + \gamma_w \Delta\theta} = \frac{f_b}{1 + \gamma_b \Delta\theta}$$

$$\Rightarrow \frac{880}{1 + 1.2 \times 10^{-3} \Delta\theta} = \frac{900}{1 + 1.5 \times 10^{-3} \Delta\theta}$$

$$\Rightarrow 880 + 880 \times 1.5 \times 10^{-3} (\Delta\theta) = 900 + 900 \times 1.2 \times 10^{-3} (\Delta\theta)$$

$$\Rightarrow (880 \times 1.5 \times 10^{-3} - 900 \times 1.2 \times 10^{-3}) (\Delta\theta) = 20$$

$$\Rightarrow (1320 - 1080) \times 10^{-3} (\Delta\theta) = 20$$

$$\Rightarrow \Delta\theta = 83.3^\circ\text{C} \approx 83^\circ\text{C}$$

26. $\Delta L = 100^\circ\text{C}$

A longitudinal strain develops if and only if, there is an opposition to the expansion. Since there is no opposition in this case, hence the longitudinal stain here = Zero.

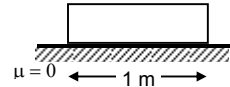

27. $\theta_1 = 20^\circ\text{C}$, $\theta_2 = 50^\circ\text{C}$

$$\alpha_{\text{steel}} = 1.2 \times 10^{-5} /^\circ\text{C}$$

Longitudinal stain = ?

$$\text{Stain} = \frac{\Delta L}{L} = \frac{L\alpha\Delta\theta}{L} = \alpha\Delta\theta$$

$$= 1.2 \times 10^{-5} \times (50 - 20) = 3.6 \times 10^{-4}$$

28. $A = 0.5\text{mm}^2 = 0.5 \times 10^{-6} \text{m}^2$

$$T_1 = 20^\circ\text{C}, T_2 = 0^\circ\text{C}$$

$$\alpha_s = 1.2 \times 10^{-5} /^\circ\text{C}, \quad Y = 2 \times 2 \times 10^{11} \text{N/m}^2$$

$$\text{Decrease in length due to compression} = L\alpha\Delta\theta \quad \dots(1)$$

$$Y = \frac{\text{Stress}}{\text{Strain}} = \frac{F}{A} \times \frac{L}{\Delta L} \Rightarrow \Delta L = \frac{FL}{AY} \quad \dots(2)$$

Tension is developed due to (1) & (2)

Equating them,

$$L\alpha\Delta\theta = \frac{FL}{AY} \Rightarrow F = \alpha\Delta\theta AY$$

$$= 1.2 \times 10^{-5} \times (20 - 0) \times 0.5 \times 10^{-6} \times 2 \times 10^{11} = 24 \text{ N}$$

29. $\theta_1 = 20^\circ\text{C}$, $\theta_2 = 100^\circ\text{C}$

$$A = 2\text{mm}^2 = 2 \times 10^{-6} \text{m}^2$$

$$\alpha_{\text{steel}} = 12 \times 10^{-6} /^\circ\text{C}, \quad Y_{\text{steel}} = 2 \times 10^{11} \text{N/m}^2$$

Force exerted on the clamps = ?

$$\left(\frac{F}{A}\right)_{\text{Strain}} = Y \Rightarrow F = \frac{Y \times \Delta L}{L} \times L = \frac{YL\alpha\Delta\theta A}{L} = YA\alpha\Delta\theta$$

$$= 2 \times 10^{11} \times 2 \times 10^{-6} \times 12 \times 10^{-6} \times 80 = 384 \text{ N}$$

30. Let the final length of the system at system of temp. $0^\circ\text{C} = \ell_0$

Initial length of the system = ℓ_0

When temp. changes by θ .

$$\text{Strain of the system} = \ell_1 - \frac{\ell_0}{\ell_0}$$

$$\text{But the total strain of the system} = \frac{\text{total stress of system}}{\text{total young's modulus of system}}$$

Now, total stress = Stress due to two steel rod + Stress due to Aluminium

$$= \gamma_s \alpha_s \theta + \gamma_s ds \theta + \gamma_{\text{al}} \text{ at } \theta = 2\% \alpha_s \theta + \gamma_2 A \ell \theta$$

$$\text{Now young' modulus of system} = \gamma_s + \gamma_s + \gamma_{\text{al}} = 2\gamma_s + \gamma_{\text{al}}$$

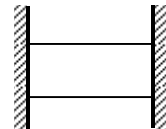

Steel
Aluminium
Steel

$$\therefore \text{Strain of system} = \frac{2\gamma_s\alpha_s\theta + \gamma_s\alpha_{al}\theta}{2\gamma_s + \gamma_{al}}$$

$$\Rightarrow \frac{l_\theta - l_0}{l_0} = \frac{2\gamma_s\alpha_s\theta + \gamma_s\alpha_{al}\theta}{2\gamma_s + \gamma_{al}}$$

$$\Rightarrow l_\theta = l_0 \left[\frac{1 + \alpha_{al}\gamma_{al} + 2\alpha_s\gamma_s\theta}{\gamma_{al} + 2\gamma_s} \right]$$

31. The ball tries to expand its volume. But it is kept in the same volume. So it is kept at a constant volume. So the stress arises

$$\frac{P}{\left(\frac{\Delta V}{V}\right)} = B \Rightarrow P = B \frac{\Delta V}{V} = B \times \gamma \Delta \theta$$

$$= B \times 3\alpha \Delta \theta = 1.6 \times 10^{11} \times 10^{-6} \times 3 \times 12 \times 10^{-6} \times (120 - 20) = 57.6 \times 19^7 \approx 5.8 \times 10^8 \text{ pa.}$$

32. Given

I_0 = Moment of Inertia at 0°C

α = Coefficient of linear expansion

To prove, $I = I_0 (1 + 2\alpha\theta)$

Let the temp. change to θ from 0°C

$\Delta T = \theta$

Let 'R' be the radius of Gyration,

Now, $R' = R (1 + \alpha\theta)$, $I_0 = MR^2$ where M is the mass.

Now, $I' = MR'^2 = MR^2 (1 + \alpha\theta)^2 \approx MR^2 (1 + 2\alpha\theta)$

[By binomial expansion or neglecting $\alpha^2 \theta^2$ which given a very small value.]

So, $I = I_0 (1 + 2\alpha\theta)$ (proved)

33. Let the initial m.I. at 0°C be I_0

$$T = 2\pi \sqrt{\frac{I}{K}}$$

$I = I_0 (1 + 2\alpha\Delta\theta)$ (from above question)

$$\text{At } 5^\circ\text{C}, \quad T_1 = 2\pi \sqrt{\frac{I_0(1+2\alpha\Delta\theta)}{K}} = 2\pi \sqrt{\frac{I_0(1+2\alpha 5)}{K}} = 2\pi \sqrt{\frac{I_0(1+10\alpha)}{K}}$$

$$\text{At } 45^\circ\text{C}, \quad T_2 = 2\pi \sqrt{\frac{I_0(1+2\alpha 45)}{K}} = 2\pi \sqrt{\frac{I_0(1+90\alpha)}{K}}$$

$$\frac{T_2}{T_1} = \sqrt{\frac{1+90\alpha}{1+10\alpha}} = \sqrt{\frac{1+90 \times 2.4 \times 10^{-5}}{1+10 \times 2.4 \times 10^{-5}}} = \sqrt{\frac{1.00216}{1.00024}}$$

$$\% \text{ change} = \left(\frac{T_2}{T_1} - 1 \right) \times 100 = 0.0959\% = 9.6 \times 10^{-2}\%$$

34. $T_1 = 20^\circ\text{C}$, $T_2 = 50^\circ\text{C}$, $\Delta T = 30^\circ\text{C}$

$\alpha = 1.2 \times 10^5 /^\circ\text{C}$

ω remains constant

$$(I) \omega = \frac{V}{R} \quad (II) \omega = \frac{V'}{R'}$$

Now, $R' = R(1 + \alpha\Delta\theta) = R + R \times 1.2 \times 10^5 \times 30 = 1.00036R$

From (I) and (II)

$$\frac{V}{R} = \frac{V'}{R'} = \frac{V'}{1.00036R}$$

$$\Rightarrow V' = 1.00036 V$$

$$\% \text{ change} = \frac{(1.00036V - V)}{V} \times 100 = 0.00036 \times 100 = 3.6 \times 10^{-2}$$

*** **

CHAPTER 24 KINETIC THEORY OF GASES

1. Volume of 1 mole of gas

$$PV = nRT \Rightarrow V = \frac{RT}{P} = \frac{0.082 \times 273}{1} = 22.38 \approx 22.4 \text{ L} = 22.4 \times 10^{-3} = 2.24 \times 10^{-2} \text{ m}^3$$

2. $n = \frac{PV}{RT} = \frac{1 \times 1 \times 10^{-3}}{0.082 \times 273} = \frac{10^{-3}}{22.4} = \frac{1}{22400}$

$$\text{No of molecules} = 6.023 \times 10^{23} \times \frac{1}{22400} = 2.688 \times 10^{19}$$

3. $V = 1 \text{ cm}^3$, $T = 0^\circ\text{C}$, $P = 10^{-5} \text{ mm of Hg}$

$$n = \frac{PV}{RT} = \frac{fgh \times V}{RT} = \frac{1.36 \times 980 \times 10^{-6} \times 1}{8.31 \times 273} = 5.874 \times 10^{-13}$$

$$\text{No. of molecules} = \text{No} \times n = 6.023 \times 10^{23} \times 5.874 \times 10^{-13} = 3.538 \times 10^{11}$$

4. $n = \frac{PV}{RT} = \frac{1 \times 1 \times 10^{-3}}{0.082 \times 273} = \frac{10^{-3}}{22.4}$

$$\text{mass} = \frac{(10^{-3} \times 32)}{22.4} \text{ g} = 1.428 \times 10^{-3} \text{ g} = 1.428 \text{ mg}$$

5. Since mass is same

$$n_1 = n_2 = n$$

$$P_1 = \frac{nR \times 300}{V_0}, \quad P_2 = \frac{nR \times 600}{2V_0}$$

$$\frac{P_1}{P_2} = \frac{nR \times 300}{V_0} \times \frac{2V_0}{nR \times 600} = \frac{1}{1} = 1 : 1$$

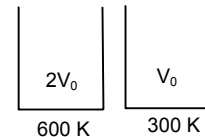

6. $V = 250 \text{ cc} = 250 \times 10^{-3}$

$$P = 10^{-3} \text{ mm} = 10^{-3} \times 10^{-3} \text{ m} = 10^{-6} \times 13600 \times 10 \text{ pascal} = 136 \times 10^{-3} \text{ pascal}$$

$$T = 27^\circ\text{C} = 300 \text{ K}$$

$$n = \frac{PV}{RT} = \frac{136 \times 10^{-3} \times 250}{8.3 \times 300} \times 10^{-3} = \frac{136 \times 250}{8.3 \times 300} \times 10^{-6}$$

$$\text{No. of molecules} = \frac{136 \times 250}{8.3 \times 300} \times 10^{-6} \times 6 \times 10^{23} = 81 \times 10^{17} \approx 0.8 \times 10^{15}$$

7. $P_1 = 8.0 \times 10^5 \text{ Pa}$, $P_2 = 1 \times 10^6 \text{ Pa}$, $T_1 = 300 \text{ K}$, $T_2 = ?$

$$\text{Since, } V_1 = V_2 = V$$

$$\frac{P_1 V_1}{T_1} = \frac{P_2 V_2}{T_2} \Rightarrow \frac{8 \times 10^5 \times V}{300} = \frac{1 \times 10^6 \times V}{T_2} \Rightarrow T_2 = \frac{1 \times 10^6 \times 300}{8 \times 10^5} = 375^\circ \text{ K}$$

8. $m = 2 \text{ g}$, $V = 0.02 \text{ m}^3 = 0.02 \times 10^6 \text{ cc} = 0.02 \times 10^3 \text{ L}$, $T = 300 \text{ K}$, $P = ?$
 $M = 2 \text{ g}$,

$$PV = nRT \Rightarrow PV = \frac{m}{M} RT \Rightarrow P \times 20 = \frac{2}{2} \times 0.082 \times 300$$

$$\Rightarrow P = \frac{0.082 \times 300}{20} = 1.23 \text{ atm} = 1.23 \times 10^5 \text{ pa} \approx 1.23 \times 10^5 \text{ pa}$$

9. $P = \frac{nRT}{V} = \frac{m}{M} \times \frac{RT}{V} = \frac{fRT}{M}$

$$f \rightarrow 1.25 \times 10^{-3} \text{ g/cm}^3$$

$$R \rightarrow 8.31 \times 10^7 \text{ ert/deg/mole}$$

$$T \rightarrow 273 \text{ K}$$

$$\Rightarrow M = \frac{fRT}{P} = \frac{1.25 \times 10^{-3} \times 8.31 \times 10^7 \times 273}{13.6 \times 980 \times 76} = 0.002796 \times 10^4 \approx 28 \text{ g/mol}$$

10. T at Simla = $15^{\circ}\text{C} = 15 + 273 = 288\text{ K}$
 P at Simla = $72\text{ cm} = 72 \times 10^{-2} \times 13600 \times 9.8$
 T at Kalka = $35^{\circ}\text{C} = 35 + 273 = 308\text{ K}$
 P at Kalka = $76\text{ cm} = 76 \times 10^{-2} \times 13600 \times 9.8$
 $PV = nRT$

$$\Rightarrow PV = \frac{m}{M}RT \Rightarrow PM = \frac{m}{V}RT \Rightarrow f = \frac{PM}{RT}$$

$$\frac{f_{\text{Simla}}}{f_{\text{Kalka}}} = \frac{P_{\text{Simla}} \times M}{RT_{\text{Simla}}} \times \frac{RT_{\text{Kalka}}}{P_{\text{Kalka}} \times M}$$

$$= \frac{72 \times 10^{-2} \times 13600 \times 9.8 \times 308}{288 \times 76 \times 10^{-2} \times 13600 \times 9.8} = \frac{72 \times 308}{76 \times 288} = 1.013$$

$$\frac{f_{\text{Kalka}}}{f_{\text{Simla}}} = \frac{1}{1.013} = 0.987$$

11. $n_1 = n_2 = n$

$$P_1 = \frac{nRT}{V}, \quad P_2 = \frac{nRT}{3V}$$

$$\frac{P_1}{P_2} = \frac{nRT}{V} \times \frac{3V}{nRT} = 3 : 1$$

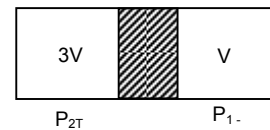
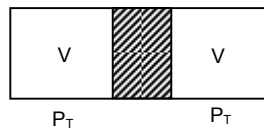

12. r.m.s velocity of hydrogen molecules = ?

$$T = 300\text{ K}, \quad R = 8.3, \quad M = 2\text{ g} = 2 \times 10^{-3}\text{ Kg}$$

$$C = \sqrt{\frac{3RT}{M}} \Rightarrow C = \sqrt{\frac{3 \times 8.3 \times 300}{2 \times 10^{-3}}} = 1932.6\text{ m/s} \approx 1930\text{ m/s}$$

Let the temp. at which the $C = 2 \times 1932.6$ is T'

$$2 \times 1932.6 = \sqrt{\frac{3 \times 8.3 \times T'}{2 \times 10^{-3}}} \Rightarrow (2 \times 1932.6)^2 = \frac{3 \times 8.3 \times T'}{2 \times 10^{-3}}$$

$$\Rightarrow \frac{(2 \times 1932.6)^2 \times 2 \times 10^{-3}}{3 \times 8.3} = T'$$

$$\Rightarrow T' = 1199.98 \approx 1200\text{ K.}$$

13. $V_{\text{rms}} = \sqrt{\frac{3P}{f}} \quad P = 10^5\text{ Pa} = 1\text{ atm}, \quad f = \frac{1.77 \times 10^{-4}}{10^{-3}}$

$$= \sqrt{\frac{3 \times 10^5 \times 10^{-3}}{1.77 \times 10^{-4}}} = 1301.8 \approx 1302\text{ m/s.}$$

14. Agv. K.E. = $3/2\text{ KT}$

$$3/2\text{ KT} = 0.04 \times 1.6 \times 10^{-19}$$

$$\Rightarrow (3/2) \times 1.38 \times 10^{-23} \times T = 0.04 \times 1.6 \times 10^{-19}$$

$$\Rightarrow T = \frac{2 \times 0.04 \times 1.6 \times 10^{-19}}{3 \times 1.38 \times 10^{-23}} = 0.0309178 \times 10^4 = 309.178 \approx 310\text{ K}$$

15. $V_{\text{avg}} = \sqrt{\frac{8RT}{\pi M}} = \sqrt{\frac{8 \times 8.3 \times 300}{3.14 \times 0.032}}$

$$T = \frac{\text{Distance}}{\text{Speed}} = \frac{6400000 \times 2}{445.25} = 445.25\text{ m/s}$$

$$= \frac{28747.83}{3600}\text{ km} = 7.985 \approx 8\text{ hrs.}$$

16. $M = 4 \times 10^{-3}\text{ Kg}$

$$V_{\text{avg}} = \sqrt{\frac{8RT}{\pi M}} = \sqrt{\frac{8 \times 8.3 \times 273}{3.14 \times 4 \times 10^{-3}}} = 1201.35$$

$$\text{Momentum} = M \times V_{\text{avg}} = 6.64 \times 10^{-27} \times 1201.35 = 7.97 \times 10^{-24} \approx 8 \times 10^{-24}\text{ Kg-m/s.}$$

$$17. V_{\text{avg}} = \sqrt{\frac{8RT}{\pi M}} = \frac{8 \times 8.3 \times 300}{3.14 \times 0.032}$$

$$\text{Now, } \frac{8RT_1}{\pi \times 2} = \frac{8RT_2}{\pi \times 4} \quad \frac{T_1}{T_2} = \frac{1}{2}$$

$$18. \text{ Mean speed of the molecule} = \sqrt{\frac{8RT}{\pi M}}$$

$$\text{Escape velocity} = \sqrt{2gr}$$

$$\sqrt{\frac{8RT}{\pi M}} = \sqrt{2gr} \Rightarrow \frac{8RT}{\pi M} = 2gr$$

$$\Rightarrow T = \frac{2gr\pi M}{8R} = \frac{2 \times 9.8 \times 6400000 \times 3.14 \times 2 \times 10^{-3}}{8 \times 8.3} = 11863.9 \approx 11800 \text{ m/s.}$$

$$19. V_{\text{avg}} = \sqrt{\frac{8RT}{\pi M}}$$

$$\frac{V_{\text{avg}H_2}}{V_{\text{avg}N_2}} = \sqrt{\frac{8RT}{\pi \times 2}} \times \sqrt{\frac{\pi \times 28}{8RT}} = \sqrt{\frac{28}{2}} = \sqrt{14} = 3.74$$

20. The left side of the container has a gas, let having molecular wt. M_1

Right part has Mol. wt = M_2

Temperature of both left and right chambers are equal as the separating wall is diathermic

$$\sqrt{\frac{3RT}{M_1}} = \sqrt{\frac{8RT}{\pi M_2}} \Rightarrow \frac{3RT}{M_1} = \frac{8RT}{\pi M_2} \Rightarrow \frac{M_1}{\pi M_2} = \frac{3}{8} \Rightarrow \frac{M_1}{M_2} = \frac{3\pi}{8} = 1.1775 \approx 1.18$$

$$21. V_{\text{mean}} = \sqrt{\frac{8RT}{\pi M}} = \sqrt{\frac{8 \times 8.3 \times 273}{3.14 \times 2 \times 10^{-3}}} = 1698.96$$

$$\text{Total Dist} = 1698.96 \text{ m}$$

$$\text{No. of Collisions} = \frac{1698.96}{1.38 \times 10^{-7}} = 1.23 \times 10^{10}$$

22. $P = 1 \text{ atm} = 10^5 \text{ Pascal}$

$$T = 300 \text{ K, } M = 2 \text{ g} = 2 \times 10^{-3} \text{ Kg}$$

$$(a) V_{\text{avg}} = \sqrt{\frac{8RT}{\pi M}} = \sqrt{\frac{8 \times 8.3 \times 300}{3.14 \times 2 \times 10^{-3}}} = 1781.004 \approx 1780 \text{ m/s}$$

(b) When the molecules strike at an angle 45° ,

$$\text{Force exerted} = mV \cos 45^\circ - (-mV \cos 45^\circ) = 2mV \cos 45^\circ = 2mV \frac{1}{\sqrt{2}} = \sqrt{2}mV$$

$$\text{No. of molecules striking per unit area} = \frac{\text{Force}}{\sqrt{2}mv \times \text{Area}} = \frac{\text{Pressure}}{\sqrt{2}mV}$$

$$= \frac{10^5}{\sqrt{2} \times 2 \times 10^{-3} \times 1780} = \frac{3}{\sqrt{2} \times 1780} \times 10^{31} = 1.19 \times 10^{-3} \times 10^{31} = 1.19 \times 10^{28} \approx 1.2 \times 10^{28}$$

$$23. \frac{P_1 V_1}{T_1} = \frac{P_2 V_2}{T_2}$$

$$P_1 \rightarrow 200 \text{ KPa} = 2 \times 10^5 \text{ pa}$$

$$P_2 = ?$$

$$T_1 = 20^\circ\text{C} = 293 \text{ K}$$

$$T_2 = 40^\circ\text{C} = 313 \text{ K}$$

$$V_2 = V_1 + 2\% V_1 = \frac{102 \times V_1}{100}$$

$$\Rightarrow \frac{2 \times 10^5 \times V_1}{293} = \frac{P_2 \times 102 \times V_1}{100 \times 313} \Rightarrow P_2 = \frac{2 \times 10^7 \times 313}{102 \times 293} = 209462 \text{ Pa} = 209.462 \text{ KPa}$$

$$24. V_1 = 1 \times 10^{-3} \text{ m}^3, \quad P_1 = 1.5 \times 10^5 \text{ Pa}, \quad T_1 = 400 \text{ K}$$

$$P_1 V_1 = n_1 R_1 T_1$$

$$\Rightarrow n = \frac{P_1 V_1}{R_1 T_1} = \frac{1.5 \times 10^5 \times 1 \times 10^{-3}}{8.3 \times 400} \Rightarrow n = \frac{1.5}{8.3 \times 4}$$

$$\Rightarrow m_1 = \frac{1.5}{8.3 \times 4} \times M = \frac{1.5}{8.3 \times 4} \times 32 = 1.4457 \approx 1.446$$

$$P_2 = 1 \times 10^5 \text{ Pa}, \quad V_2 = 1 \times 10^{-3} \text{ m}^3, \quad T_2 = 300 \text{ K}$$

$$P_2 V_2 = n_2 R_2 T_2$$

$$\Rightarrow n_2 = \frac{P_2 V_2}{R_2 T_2} = \frac{10^5 \times 10^{-3}}{8.3 \times 300} = \frac{1}{3 \times 8.3} = 0.040$$

$$\Rightarrow m_2 = 0.04 \times 32 = 1.285$$

$$\Delta m = m_1 - m_2 = 1.446 - 1.285 = 0.1608 \text{ g} \approx 0.16 \text{ g}$$

$$25. P_1 = 10^5 + fgh = 10^5 + 1000 \times 10 \times 3.3 = 1.33 \times 10^5 \text{ pa}$$

$$P_2 = 10^5, \quad T_1 = T_2 = T, \quad V_1 = \frac{4}{3} \pi (2 \times 10^{-3})^3$$

$$V_2 = \frac{4}{3} \pi r^3, \quad r = ?$$

$$\frac{P_1 V_1}{T_1} = \frac{P_2 V_2}{T_2}$$

$$\Rightarrow \frac{1.33 \times 10^5 \times \frac{4}{3} \times \pi \times (2 \times 10^{-3})^3}{T_1} = \frac{10^5 \times \frac{4}{3} \times \pi r^3}{T_2}$$

$$\Rightarrow 1.33 \times 8 \times 10^5 \times 10^{-9} = 10^5 \times r^3 \quad \Rightarrow r = \sqrt[3]{10.64 \times 10^{-3}} = 2.19 \times 10^{-3} \approx 2.2 \text{ mm}$$

$$26. P_1 = 2 \text{ atm} = 2 \times 10^5 \text{ pa}$$

$$V_1 = 0.002 \text{ m}^3, \quad T_1 = 300 \text{ K}$$

$$P_1 V_1 = n_1 R T_1$$

$$\Rightarrow n = \frac{P_1 V_1}{R T_1} = \frac{2 \times 10^5 \times 0.002}{8.3 \times 300} = \frac{4}{8.3 \times 3} = 0.1606$$

$$P_2 = 1 \text{ atm} = 10^5 \text{ pa}$$

$$V_2 = 0.0005 \text{ m}^3, \quad T_2 = 300 \text{ K}$$

$$P_2 V_2 = n_2 R T_2$$

$$\Rightarrow n_2 = \frac{P_2 V_2}{R T_2} = \frac{10^5 \times 0.0005}{8.3 \times 300} = \frac{5}{3 \times 8.3} \times \frac{1}{10} = 0.02$$

$$\Delta n = \text{moles leaked out} = 0.16 - 0.02 = 0.14$$

$$27. m = 0.040 \text{ g}, \quad T = 100^\circ\text{C}, \quad M_{\text{He}} = 4 \text{ g}$$

$$U = \frac{3}{2} n R t = \frac{3}{2} \times \frac{m}{M} \times R T \quad T' = ?$$

$$\text{Given } \frac{3}{2} \times \frac{m}{M} \times R T + 12 = \frac{3}{2} \times \frac{m}{M} \times R T'$$

$$\Rightarrow 1.5 \times 0.01 \times 8.3 \times 373 + 12 = 1.5 \times 0.01 \times 8.3 \times T'$$

$$\Rightarrow T' = \frac{58.4385}{0.1245} = 469.3855 \text{ K} = 196.3^\circ\text{C} \approx 196^\circ\text{C}$$

$$28. P V^2 = \text{constant}$$

$$\Rightarrow P_1 V_1^2 = P_2 V_2^2$$

$$\Rightarrow \frac{n R T_1}{V_1} \times V_1^2 = \frac{n R T_2}{V_2} \times V_2^2$$

$$\Rightarrow T_1 V_1 = T_2 V_2 = T V = T_1 \times 2V \Rightarrow T_2 = \frac{T}{2}$$

$$29. P_{O_2} = \frac{n_{O_2}RT}{V}, \quad P_{H_2} = \frac{n_{H_2}RT}{V}$$

$$n_{O_2} = \frac{m}{M_{O_2}} = \frac{1.60}{32} = 0.05$$

$$\text{Now, } P_{\text{mix}} = \left(\frac{n_{O_2} + n_{H_2}}{V} \right) RT$$

$$n_{H_2} = \frac{m}{M_{H_2}} = \frac{2.80}{28} = 0.1$$

$$P_{\text{mix}} = \frac{(0.05 + 0.1) \times 8.3 \times 300}{0.166} = 2250 \text{ N/m}^2$$

$$30. P_1 = \text{Atmospheric pressure} = 75 \times fg$$

$$V_1 = 100 \times A$$

$$P_2 = \text{Atmospheric pressure} + \text{Mercury pressure} = 75fg + hfg \text{ (if } h = \text{height of mercury)}$$

$$V_2 = (100 - h) A$$

$$P_1V_1 = P_2V_2$$

$$\Rightarrow 75fg(100A) = (75 + h)fg(100 - h)A$$

$$\Rightarrow 75 \times 100 = (75 + h)(100 - h) \Rightarrow 7500 = 7500 - 75h + 100h - h^2$$

$$\Rightarrow h^2 - 25h = 0 \Rightarrow h^2 = 25h \Rightarrow h = 25 \text{ cm}$$

Height of mercury that can be poured = 25 cm

$$31. \text{ Now, Let the final pressure; Volume \& Temp be}$$

After connection = P_A' → Partial pressure of A

P_B' → Partial pressure of B

$$\text{Now, } \frac{P_A' \times 2V}{T} = \frac{P_A \times V}{T_A}$$

$$\text{Or } \frac{P_A'}{T} = \frac{P_A}{2T_A} \quad \dots(1)$$

$$\text{Similarly, } \frac{P_B'}{T} = \frac{P_B}{2T_B} \quad \dots(2)$$

Adding (1) & (2)

$$\frac{P_A'}{T} + \frac{P_B'}{T} = \frac{P_A}{2T_A} + \frac{P_B}{2T_B} = \frac{1}{2} \left(\frac{P_A}{T_A} + \frac{P_B}{T_B} \right)$$

$$\Rightarrow \frac{P}{T} = \frac{1}{2} \left(\frac{P_A}{T_A} + \frac{P_B}{T_B} \right) \quad [\because P_A' + P_B' = P]$$

$$32. V = 50 \text{ cc} = 50 \times 10^{-6} \text{ cm}^3$$

$$P = 100 \text{ KPa} = 10^5 \text{ Pa}$$

$$M = 28.8 \text{ g}$$

$$(a) PV = nrT_1$$

$$\Rightarrow PV = \frac{m}{M}RT_1 \Rightarrow m = \frac{PMV}{RT_1} = \frac{10^5 \times 28.8 \times 50 \times 10^{-6}}{8.3 \times 273} = \frac{50 \times 28.8 \times 10^{-1}}{8.3 \times 273} = 0.0635 \text{ g.}$$

(b) When the vessel is kept on boiling water

$$PV = \frac{m}{M}RT_2 \Rightarrow m = \frac{PVM}{RT_2} = \frac{10^5 \times 28.8 \times 50 \times 10^{-6}}{8.3 \times 373} = \frac{50 \times 28.8 \times 10^{-1}}{8.3 \times 373} = 0.0465$$

(c) When the vessel is closed

$$P \times 50 \times 10^{-6} = \frac{0.0465}{28.8} \times 8.3 \times 273$$

$$\Rightarrow P = \frac{0.0465 \times 8.3 \times 273}{28.8 \times 50 \times 10^{-6}} = 0.07316 \times 10^6 \text{ Pa} \approx 73 \text{ KPa}$$

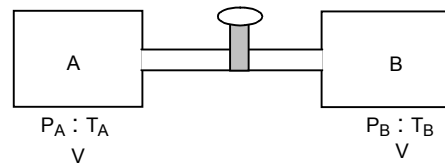

33. Case I → Net pressure on air in volume V
 $= P_{atm} - hfg = 75 \times f_{Hg} - 10 f_{Hg} = 65 \times f_{Hg} \times g$
Case II → Net pressure on air in volume 'V' = $P_{atm} + f_{Hg} \times g \times h$
 $P_1 V_1 = P_2 V_2$
 $\Rightarrow f_{Hg} \times g \times 65 \times A \times 20 = f_{Hg} \times g \times 75 + f_{Hg} \times g \times 10 \times A \times h$
 $\Rightarrow 62 \times 20 = 85 h \Rightarrow h = \frac{65 \times 20}{85} = 15.2 \text{ cm} \approx 15 \text{ cm}$

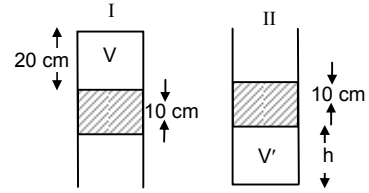

34. $2L + 10 = 100 \Rightarrow 2L = 90 \Rightarrow L = 45 \text{ cm}$
 Applying combined gas eqn to part 1 of the tube

$$\frac{(45A)P_0}{300} = \frac{(45-x)P_1}{273}$$

$$\Rightarrow P_1 = \frac{273 \times 45 \times P_0}{300(45-x)}$$

Applying combined gas eqn to part 2 of the tube

$$\frac{45AP_0}{300} = \frac{(45+x)AP_2}{400}$$

$$\Rightarrow P_2 = \frac{400 \times 45 \times P_0}{300(45+x)}$$

$$P_1 = P_2$$

$$\Rightarrow \frac{273 \times 45 \times P_0}{300(45-x)} = \frac{400 \times 45 \times P_0}{300(45+x)}$$

$$\Rightarrow (45-x)400 = (45+x)273 \Rightarrow 18000 - 400x = 12285 + 273x$$

$$\Rightarrow (400+273)x = 18000 - 12285 \Rightarrow x = 8.49$$

$$P_1 = \frac{273 \times 46 \times 76}{300 \times 36.51} = 85 \% \text{ 25 cm of Hg}$$

Length of air column on the cooler side = $L - x = 45 - 8.49 = 36.51$

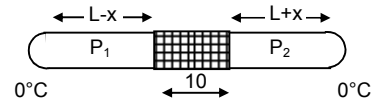
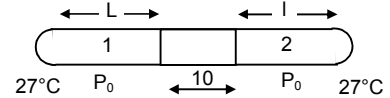

35. Case I Atmospheric pressure + pressure due to mercury column
Case II Atmospheric pressure + Component of the pressure due to mercury column

$$P_1 V_1 = P_2 V_2$$

$$\Rightarrow (76 \times f_{Hg} \times g + f_{Hg} \times g \times 20) \times A \times 43$$

$$= (76 \times f_{Hg} \times g + f_{Hg} \times g \times 20 \times \cos 60^\circ) \times A \times \ell$$

$$\Rightarrow 96 \times 43 = 86 \times \ell$$

$$\Rightarrow \ell = \frac{96 \times 43}{86} = 48 \text{ cm}$$

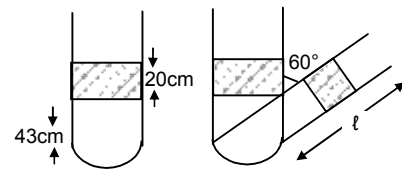

36. The middle wall is weakly conducting. Thus after a long time the temperature of both the parts will equalise.
 The final position of the separating wall be at distance x from the left end. So it is at a distance $30 - x$ from the right end

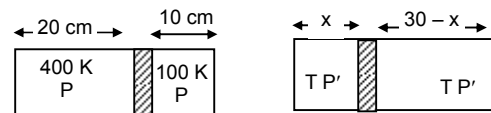

Putting combined gas equation of one side of the separating wall,

$$\frac{P_1 \times V_1}{T_1} = \frac{P_2 \times V_2}{T_2}$$

$$\Rightarrow \frac{P \times 20A}{400} = \frac{P' \times A}{T} \quad \dots(1)$$

$$\Rightarrow \frac{P \times 10A}{100} = \frac{P'(30-x)}{T} \quad \dots(2)$$

Equating (1) and (2)

$$\Rightarrow \frac{1}{2} = \frac{x}{30-x} \Rightarrow 30-x = 2x \Rightarrow 3x = 30 \Rightarrow x = 10 \text{ cm}$$

The separator will be at a distance 10 cm from left end.

$$37. \frac{dV}{dt} = r \Rightarrow dV = r dt$$

Let the pumped out gas pressure dp

Volume of container = V_0 At a pump dv amount of gas has been pumped out.

$$Pdv = -V_0df \Rightarrow P_V df = -V_0 dp$$

$$\Rightarrow \int_P^P \frac{dp}{p} = - \int_0^t \frac{dr}{V_0} \Rightarrow P = P_0 e^{-rt/V_0}$$

Half of the gas has been pumped out, Pressure will be half = $\frac{1}{2} P_0 e^{-rt/V_0}$

$$\Rightarrow \ln 2 = \frac{rt}{V_0} \quad \Rightarrow t = \frac{V_0 \ln 2}{r}$$

$$38. P = \frac{P_0}{1 + \left(\frac{V}{V_0}\right)^2}$$

$$\Rightarrow \frac{nRT}{V} = \frac{P_0}{1 + \left(\frac{V}{V_0}\right)^2} \quad [PV = nRT \text{ according to ideal gas equation}]$$

$$\Rightarrow \frac{RT}{V} = \frac{P_0}{1 + \left(\frac{V}{V_0}\right)^2} \quad [\text{Since } n = 1 \text{ mole}]$$

$$\Rightarrow \frac{RT}{V_0} = \frac{P_0}{1 + \left(\frac{V}{V_0}\right)^2} \quad [\text{At } V = V_0]$$

$$\Rightarrow P_0 V_0 = RT(1 + 1) \Rightarrow P_0 V_0 = 2 RT \Rightarrow T = \frac{P_0 V_0}{2R}$$

39. Internal energy = nRT

Now, $PV = nRT$

$$nT = \frac{PV}{R} \quad \text{Here } P \text{ \& } V \text{ constant}$$

$\Rightarrow nT$ is constant

\therefore Internal energy = $R \times \text{Constant} = \text{Constant}$

40. Frictional force = μN

Let the cork moves to a distance = dl

\therefore Work done by frictional force = $\mu N dl$

Before that the work will not start that means volume remains constant

$$\Rightarrow \frac{P_1}{T_1} = \frac{P_2}{T_2} \Rightarrow \frac{1}{300} = \frac{P_2}{600} \Rightarrow P_2 = 2 \text{ atm}$$

\therefore Extra Pressure = $2 \text{ atm} - 1 \text{ atm} = 1 \text{ atm}$

Work done by cork = $1 \text{ atm} (A dl) \quad \mu N dl = [1 \text{ atm}][A dl]$

$$N = \frac{1 \times 10^5 \times (5 \times 10^{-2})^2}{2} = \frac{1 \times 10^5 \times \pi \times 25 \times 10^{-5}}{2}$$

$$\text{Total circumference of work} = 2\pi r \frac{dN}{dl} = \frac{N}{2\pi r}$$

$$= \frac{1 \times 10^5 \times \pi \times 25 \times 10^{-5}}{0.2 \times 2\pi r} = \frac{1 \times 10^5 \times 25 \times 10^{-5}}{0.2 \times 2 \times 5 \times 10^{-5}} = 1.25 \times 10^4 \text{ N/m}$$

$$41. \frac{P_1 V_1}{T_1} = \frac{P_2 V_2}{T_2}$$

$$\Rightarrow \frac{P_0 V}{T_0} = \frac{P' V}{2T_0} \Rightarrow P' = 2P_0$$

Net pressure = P_0 outwards

\therefore Tension in wire = $P_0 A$

Where A is area of tube.

$$42. (a) 2P_0 x = (h_2 + h_0)fg \quad [\because \text{Since liquid at the same level have same pressure}]$$

$$\Rightarrow 2P_0 = h_2 fg + h_0 fg$$

$$\Rightarrow h_2 fg = 2P_0 - h_0 fg$$

$$h_2 = \frac{2P_0}{fg} - \frac{h_0 fg}{fg} = \frac{2P_0}{fg} - h_0$$

(b) K.E. of the water = Pressure energy of the water at that layer

$$\Rightarrow \frac{1}{2} mV^2 = m \times \frac{P}{f}$$

$$\Rightarrow V^2 = \frac{2P}{f} = \left[\frac{2}{f(P_0 + fg(h_1 - h_0))} \right]$$

$$\Rightarrow V = \left[\frac{2}{f(P_0 + fg(h_1 - h_0))} \right]^{1/2}$$

$$(c) (x + P_0)fh = 2P_0$$

$$\therefore 2P_0 + fg(h - h_0) = P_0 + fgx$$

$$\therefore x = \frac{P_0}{fg + h_1 - h_0} = h_2 + h_1$$

\therefore i.e. x is h_1 meter below the top \Rightarrow x is $-h_1$ above the top

$$43. A = 100 \text{ cm}^2 = 10^{-3} \text{ m}^2$$

$$m = 1 \text{ kg}, \quad P = 100 \text{ kPa} = 10^5 \text{ Pa}$$

$$l = 20 \text{ cm}$$

Case I = External pressure exists

Case II = Internal Pressure does not exist

$$P_1 V_1 = P_2 V_2$$

$$\Rightarrow \left(10^5 + \frac{1 \times 9.8}{10^{-3}} \right) V = \frac{1 \times 9.8}{10^{-3}} \times V'$$

$$\Rightarrow (10^5 + 9.8 \times 10^3) A \times l = 9.8 \times 10^3 \times A \times l'$$

$$\Rightarrow 10^5 \times 2 \times 10^{-1} + 2 \times 9.8 \times 10^2 = 9.8 \times 10^3 \times l'$$

$$\Rightarrow l' = \frac{2 \times 10^4 + 19.6 \times 10^2}{9.8 \times 10^3} = 2.24081 \text{ m}$$

$$44. P_1 V_1 = P_2 V_2$$

$$\Rightarrow \left(\frac{mg}{A} + P_0 \right) A l = P_0 A l'$$

$$\Rightarrow \left(\frac{1 \times 9.8}{10 \times 10^{-4}} + 10^5 \right) 0.2 = 10^5 l'$$

$$\Rightarrow (9.8 \times 10^3 + 10^5) \times 0.2 = 10^5 l'$$

$$\Rightarrow 109.8 \times 10^3 \times 0.2 = 10^5 l'$$

$$\Rightarrow l' = \frac{109.8 \times 0.2}{10^2} = 0.2196 \approx 0.22 \text{ m} \approx 22 \text{ cm}$$

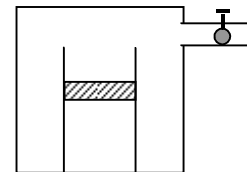
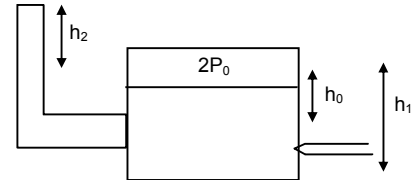
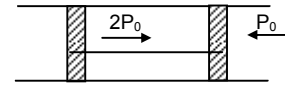

45. When the bulbs are maintained at two different temperatures.

The total heat gained by 'B' is the heat lost by 'A'

Let the final temp be x

So, $m_1 S \Delta t = m_2 S \Delta t$

$$\Rightarrow n_1 M \times s(x - 0) = n_2 M \times S \times (62 - x) \quad \Rightarrow n_1 x = 62n_2 - n_2 x$$

$$\Rightarrow x = \frac{62n_2}{n_1 + n_2} = \frac{62n_2}{2n_2} = 31^\circ\text{C} = 304 \text{ K}$$

For a single ball

Initial Temp = 0°C

$P = 76 \text{ cm of Hg}$

$$\frac{P_1 V_1}{T_1} = \frac{P_2 V_2}{T_2}$$

$V_1 = V_2$

Hence $n_1 = n_2$

$$\Rightarrow \frac{76 \times V}{273} = \frac{P_2 \times V}{304} \Rightarrow P_2 = \frac{403 \times 76}{273} = 84.630 \approx 84^\circ\text{C}$$

46. Temp is 20° Relative humidity = 100%

So the air is saturated at 20°C

Dew point is the temperature at which SVP is equal to present vapour pressure

So 20°C is the dew point.

47. $T = 25^\circ\text{C}$ $P = 104 \text{ KPa}$

$$\text{RH} = \frac{\text{VP}}{\text{SVP}} \quad [\text{SVP} = 3.2 \text{ KPa}, \quad \text{RH} = 0.6]$$

$$\text{VP} = 0.6 \times 3.2 \times 10^3 = 1.92 \times 10^3 \approx 2 \times 10^3$$

When vapours are removed VP reduces to zero

$$\text{Net pressure inside the room now} = 104 \times 10^3 - 2 \times 10^3 = 102 \times 10^3 = 102 \text{ KPa}$$

48. Temp = 20°C Dew point = 10°C

The place is saturated at 10°C

Even if the temp drop dew point remains unaffected.

The air has V.P. which is the saturation VP at 10°C . It (SVP) does not change on temp.

$$49. \text{RH} = \frac{\text{VP}}{\text{SVP}}$$

The point where the vapour starts condensing, $\text{VP} = \text{SVP}$

We know $P_1 V_1 = P_2 V_2$

$$R_H \text{ SVP} \times 10 = \text{SVP} \times V_2 \quad \Rightarrow V_2 = 10R_H \Rightarrow 10 \times 0.4 = 4 \text{ cm}^3$$

50. Atm-Pressure = 76 cm of Hg

When water is introduced the water vapour exerts some pressure which counter acts the atm pressure.

The pressure drops to 75.4 cm

$$\text{Pressure of Vapour} = (76 - 75.4) \text{ cm} = 0.6 \text{ cm}$$

$$\text{R. Humidity} = \frac{\text{VP}}{\text{SVP}} = \frac{0.6}{1} = 0.6 = 60\%$$

51. From fig. 24.6, we draw $\perp r$, from Y axis to meet the graphs.

Hence we find the temp. to be approximately 65°C & 45°C

52. The temp. of body is $98^\circ\text{F} = 37^\circ\text{C}$

At 37°C from the graph SVP = Just less than 50 mm

B.P. is the temp. when atmospheric pressure equals the atmospheric pressure.

Thus min. pressure to prevent boiling is 50 mm of Hg.

53. Given

SVP at the dew point = 8.9 mm

SVP at room temp = 17.5 mm

Dew point = 10°C as at this temp. the condensation starts

Room temp = 20°C

$$\text{RH} = \frac{\text{SVP at dew point}}{\text{SVP at room temp}} = \frac{8.9}{17.5} = 0.508 \approx 51\%$$

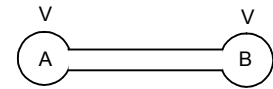

54. 50 m^3 of saturated vapour is cooled 30° to 20° . The absolute humidity of saturated H_2O vapour 30 g/m^3
 Absolute humidity is the mass of water vapour present in a given volume at 30°C , it contains 30 g/m^3
 at 50 m^3 it contains $30 \times 50 = 1500 \text{ g}$
 at 20°C it contains $16 \times 50 = 800 \text{ g}$
 Water condense = $1500 - 800 = 700 \text{ g}$.

55. Pressure is minimum when the vapour present inside are at saturation vapour pressure
 As this is the max. pressure which the vapours can exert.
 Hence the normal level of mercury drops down by 0.80 cm
 \therefore The height of the Hg column = $76 - 0.80 \text{ cm} = 75.2 \text{ cm}$ of Hg.
 [\therefore Given SVP at atmospheric temp = 0.80 cm of Hg]

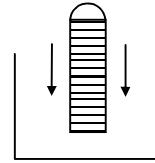

56. Pressure inside the tube = Atmospheric Pressure = 99.4 KPa
 Pressure exerted by O_2 vapour = Atmospheric pressure - V.P.
 = $99.4 \text{ KPa} - 3.4 \text{ KPa} = 96 \text{ KPa}$

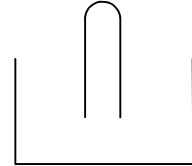

No of moles of $\text{O}_2 = n$
 $96 \times 10^3 \times 50 \times 10^{-6} = n \times 8.3 \times 300$
 $\Rightarrow n = \frac{96 \times 50 \times 10^{-3}}{8.3 \times 300} = 1.9277 \times 10^{-3} \approx 1.93 \times 10^{-3}$

57. Let the barometer has a length = x
 Height of air above the mercury column = $(x - 74 - 1) = (x - 73)$
 Pressure of air = $76 - 74 - 1 = 1 \text{ cm}$
 For 2nd case height of air above = $(x - 72.1 - 1 - 1) = (x - 71.1)$
 Pressure of air = $(74 - 72.1 - 1) = 0.99$
 $(x - 73)(1) = \frac{9}{10}(x - 71.1) \Rightarrow 10(x - 73) = 9(x - 71.1)$
 $\Rightarrow x = 10 \times 73 - 9 \times 71.1 = 730 - 639.9 = 90.1$
 Height of air = 90.1
 Height of barometer tube above the mercury column = $90.1 + 1 = 91.1 \text{ mm}$

58. Relative humidity = 40%
 SVP = 4.6 mm of Hg

$$0.4 = \frac{VP}{4.6} \Rightarrow VP = 0.4 \times 4.6 = 1.84$$

$$\frac{P_1 V}{T_1} = \frac{P_2 V}{T_2} \Rightarrow \frac{1.84}{273} = \frac{P_2}{293} \Rightarrow P_2 = \frac{1.84}{273} \times 293$$

Relative humidity at 20°C
 $= \frac{VP}{SVP} = \frac{1.84 \times 293}{273 \times 10} = 0.109 = 10.9\%$

59. $RH = \frac{VP}{SVP}$

Given, $0.50 = \frac{VP}{3600}$

$$\Rightarrow VP = 3600 \times 0.5$$

Let the Extra pressure needed be P

$$\text{So, } P = \frac{m}{M} \times \frac{RT}{V} = \frac{m}{18} \times \frac{8.3 \times 300}{1}$$

Now, $\frac{m}{18} \times 8.3 \times 300 + 3600 \times 0.50 = 3600$ [air is saturated i.e. $RH = 100\% = 1$ or $VP = SVP$]

$$\Rightarrow m = \left(\frac{36 - 18}{8.3} \right) \times 6 = 13 \text{ g}$$

60. $T = 300 \text{ K}$, Rel. humidity = 20%, $V = 50 \text{ m}^3$
 $\text{SVP at } 300 \text{ K} = 3.3 \text{ KPa}$, $\text{V.P.} = \text{Relative humidity} \times \text{SVP} = 0.2 \times 3.3 \times 10^3$

$$PV = \frac{m}{M}RT \Rightarrow 0.2 \times 3.3 \times 10^3 \times 50 = \frac{m}{18} \times 8.3 \times 300$$

$$\Rightarrow m = \frac{0.2 \times 3.3 \times 50 \times 18 \times 10^3}{8.3 \times 300} = 238.55 \text{ grams} \approx 238 \text{ g}$$

Mass of water present in the room = 238 g.

61. $\text{RH} = \frac{\text{VP}}{\text{SVP}} \Rightarrow 0.20 = \frac{\text{VP}}{3.3 \times 10^3} \Rightarrow \text{VP} = 0.2 \times 3.3 \times 10^3 = 660$

$$PV = nRT \Rightarrow P = \frac{nRT}{V} = \frac{m}{M} \times \frac{RT}{V} = \frac{500}{18} \times \frac{8.3 \times 300}{50} = 1383.3$$

$$\text{Net } P = 1383.3 + 660 = 2043.3 \quad \text{Now, } \text{RH} = \frac{2034.3}{3300} = 0.619 \approx 62\%$$

62. (a) $\text{Rel. humidity} = \frac{\text{VP}}{\text{SVP at } 15^\circ\text{C}} \Rightarrow 0.4 = \frac{\text{VP}}{1.6 \times 10^3} \Rightarrow \text{VP} = 0.4 \times 1.6 \times 10^3$

The evaporation occurs as long as the atmosphere does not become saturated.

$$\text{Net pressure change} = 1.6 \times 10^3 - 0.4 \times 1.6 \times 10^3 = (1.6 - 0.4 \times 1.6)10^3 = 0.96 \times 10^3$$

$$\text{Net mass of water evaporated} = m \Rightarrow 0.96 \times 10^3 \times 50 = \frac{m}{18} \times 8.3 \times 288$$

$$\Rightarrow m = \frac{0.96 \times 50 \times 18 \times 10^3}{8.3 \times 288} = 361.45 \approx 361 \text{ g}$$

(b) At 20°C $\text{SVP} = 2.4 \text{ KPa}$, At 15°C $\text{SVP} = 1.6 \text{ KPa}$

$$\text{Net pressure change} = (2.4 - 1.6) \times 10^3 \text{ Pa} = 0.8 \times 10^3 \text{ Pa}$$

$$\text{Mass of water evaporated} = m' = 0.8 \times 10^3 \times 50 = \frac{m'}{18} \times 8.3 \times 293$$

$$\Rightarrow m' = \frac{0.8 \times 50 \times 18 \times 10^3}{8.3 \times 293} = 296.06 \approx 296 \text{ grams}$$



CHAPTER – 25 CALORIMETRY

1. Mass of aluminium = 0.5kg, Mass of water = 0.2 kg
 Mass of Iron = 0.2 kg Temp. of aluminium and water = 20°C = 297°k
 Sp heat of Iron = 100°C = 373°k. Sp heat of aluminium = 910J/kg-k
 Sp heat of Iron = 470J/kg-k Sp heat of water = 4200J/kg-k
 Heat gain = $0.5 \times 910(T - 293) + 0.2 \times 4200 \times (343 - T)$
 $= (T - 292) (0.5 \times 910 + 0.2 \times 4200)$ Heat lost = $0.2 \times 470 \times (373 - T)$
 \therefore Heat gain = Heat lost
 $\Rightarrow (T - 292) (0.5 \times 910 + 0.2 \times 4200) = 0.2 \times 470 \times (373 - T)$
 $\Rightarrow (T - 293) (455 + 8400) = 49(373 - T)$
 $\Rightarrow (T - 293) \left(\frac{1295}{94} \right) = (373 - T)$
 $\Rightarrow (T - 293) \times 14 = 373 - T$
 $\Rightarrow T = \frac{4475}{15} = 298 \text{ k}$
 $\therefore T = 298 - 273 = 25^\circ\text{C}.$ The final temp = 25°C.
2. mass of Iron = 100g water Eq of calorimeter = 10g
 mass of water = 240g Let the Temp. of surface = 0°C
 $S_{\text{iron}} = 470\text{J/kg}^\circ\text{C}$ Total heat gained = Total heat lost.
 So, $\frac{100}{1000} \times 470 \times (\theta - 60) = \frac{250}{1000} \times 4200 \times (60 - 20)$
 $\Rightarrow 47\theta - 47 \times 60 = 25 \times 42 \times 40$
 $\Rightarrow \theta = 4200 + \frac{2820}{47} = \frac{44820}{47} = 953.61^\circ\text{C}$
3. The temp. of A = 12°C The temp. of B = 19°C
 The temp. of C = 28°C The temp of $\Rightarrow A + B = 16^\circ$
 The temp. of $\Rightarrow B + C = 23^\circ$
 In accordance with the principle of calorimetry when A & B are mixed
 $M_{CA} (16 - 12) = M_{CB} (19 - 16) \Rightarrow CA4 = CB3 \Rightarrow CA = \frac{3}{4} CB \quad \dots(1)$
 And when B & C are mixed
 $M_{CB} (23 - 19) = M_{CC} (28 - 23) \Rightarrow 4CB = 5CC \Rightarrow CC = \frac{4}{5} CB \quad \dots(2)$
 When A & c are mixed, if T is the common temperature of mixture
 $M_{CA} (T - 12) = M_{CC} (28 - T)$
 $\Rightarrow \left(\frac{3}{4} \right) CB(T - 12) = \left(\frac{4}{5} \right) CB(28 - T)$
 $\Rightarrow 15T - 180 = 448 - 16T$
 $\Rightarrow T = \frac{628}{31} = 20.258^\circ\text{C} = 20.3^\circ\text{C}$

* * * * *

CHAPTER 26
LAWS OF THERMODYNAMICS
QUESTIONS FOR SHORT ANSWER

- No in isothermal process heat is added to a system. The temperature does not increase so the internal energy does not.
- Yes, the internal energy must increase when temp. increases; as internal energy depends upon temperature $U \propto T$
- Work done on the gas is 0. as the P.E. of the container is increased and not of gas. Work done by the gas is 0. as the gas is not expanding.
The temperature of the gas is decreased.
- $W = F \times d = Fd \cos 0^\circ = Fd$
Change in PE is zero. Change in KE is non Zero.
So, there may be some internal energy.
- The outer surface of the cylinder is rubbed vigorously by a polishing machine.
The energy given to the cylinder is work. The heat is produced on the cylinder which transferred to the gas.
- No. work done by rubbing the hands is converted to heat and the hands become warm.
- When the bottle is shaken the liquid in it is also shaken. Thus work is done on the liquid. But heat is not transferred to the liquid.
- Final volume = Initial volume. So, the process is isobaric.
Work done in an isobaric process is necessarily zero.
- No work can be done by the system without changing its volume.
- Internal energy = $U = nC_vT$
Now, since gas is continuously pumped in. So $n_2 = 2n_1$ as the $p_2 = 2p_1$. Hence the internal energy is also doubled.
- When the tyre bursts, there is adiabatic expansion of the air because the pressure of the air inside is sufficiently higher than atmospheric pressure. In expansion air does some work against surroundings. So the internal energy decreases. This leads to a fall in temperature.
- 'No', work is done on the system during this process. No, because the object expands during the process i.e. volume increases.
- No, it is not a reversible process.
- Total heat input = Total heat out put i.e., the total heat energy given to the system is converted to mechanical work.
- Yes, the entropy of the body decreases. But in order to cool down a body we need another external sink which draws out the heat the entropy of object is partly transferred to the external sink. Thus once entropy is created. It is kept by universe. And it is never destroyed. This is according to the 2nd law of thermodynamics

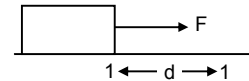

OBJECTIVE – I

- (d) $dQ = dU + dW$. This is the statement of law of conservation of energy. The energy provided is utilized to do work as well as increase the molecular K.E. and P.E.
- (b) Since it is an isothermal process. So temp. will remain constant as a result 'U' or internal energy will also remain constant. So the system has to do positive work.
- (a) In case of A $\Delta W_1 > \Delta W_2$ (Area under the graph is higher for A than for B).
 $\Delta Q = \Delta u + dw$.
du for both the processes is same (as it is a state function)
 $\therefore \Delta Q_1 > \Delta Q_2$ as $\Delta W_1 > \Delta W_2$
- (b) As Internal energy is a state function and not a path function. $\Delta U_1 = \Delta U_2$

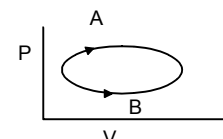
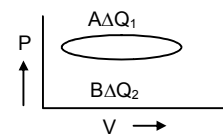

5. (a) In the process the volume of the system increases continuously. Thus, the work done increases continuously.

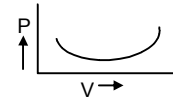

6. (c) for A → In a so thermal system temp remains same although heat is added.
for B → For the work done by the system volume increase as is consumes heat.

7. (c) In this case P and T vary proportionally i.e. $P/T = \text{constant}$. This is possible only when volume does not change. ∴ $pdv = 0$

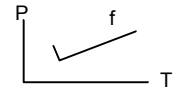

8. (c) Given : $\Delta V_A = \Delta V_B$. But $P_A < P_B$
Now, $W_A = P_A \Delta V_B$; $W_B = P_B \Delta V_B$; So, $W_A < W_B$.

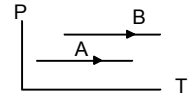

9. (b) As the volume of the gas decreases, the temperature increases as well as the pressure. But, on passage of time, the heat develops radiates through the metallic cylinder thus T decreases as well as the pressure.

OBJECTIVE – II

1. (b), (c) Pressure P and Volume V both increases. Thus work done is positive (V increases). Heat must be added to the system to follow this process. So temperature must increases.

2. (a) (b) Initial temp = Final Temp. Initial internal energy = Final internal energy.
i.e. $\Delta U = 0$, So, this is found in case of a cyclic process.



3. (d) $\Delta U = \text{Heat supplied}$, $\Delta W = \text{Work done}$.
 $(\Delta Q - \Delta W) = du$, du is same for both the methods since it is a state function.

4. (a) (c) Since it is a cyclic process.
So, $\Delta U_1 = -\Delta U_2$, hence $\Delta U_1 + \Delta U_2 = 0$
 $\Delta Q - \Delta W = 0$

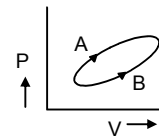

5. (a) (d) Internal energy decreases by the same amount as work done.
 $du = dw$, ∴ $dQ = 0$. Thus the process is adiabatic. In adiabatic process, $dU = -dw$. Since 'U' decreases $U_2 - U_1$ is -ve. ∴ dw should be +ve $\Rightarrow \frac{nR}{\gamma - 1} (T_1 - T_2)$ is +ve. $T_1 > T_2$ ∴ Temperature decreases.

EXERCISES

1. $t_1 = 15^\circ\text{C}$ $t_2 = 17^\circ\text{C}$
 $\Delta t = t_2 - t_1 = 17 - 15 = 2^\circ\text{C} = 2 + 273 = 275 \text{ K}$
 $m_v = 100 \text{ g} = 0.1 \text{ kg}$ $m_w = 200 \text{ g} = 0.2 \text{ kg}$
 $cu_g = 420 \text{ J/kg-k}$ $W_g = 4200 \text{ J/kg-k}$
(a) The heat transferred to the liquid vessel system is 0. The internal heat is shared in between the vessel and water.

(b) Work done on the system = Heat produced unit
 $\Rightarrow dw = 100 \times 10^{-3} \times 420 \times 2 + 200 \times 10^{-3} \times 4200 \times 2 = 84 + 84 \times 20 = 84 \times 21 = 1764 \text{ J}$.

(c) $dQ = 0$, $dU = -dw = 1764$. [since $dw = -ve$ work done on the system]

2. (a) Heat is not given to the liquid. Instead the mechanical work done is converted to heat. So, heat given to liquid is z.

(b) Work done on the liquid is the PE lost by the 12 kg mass = $mgh = 12 \times 10 \times 0.70 = 84 \text{ J}$

(c) Rise in temp at Δt We know, $84 = ms\Delta t$
 $\Rightarrow 84 = 1 \times 4200 \times \Delta t$ (for 'm' = 1kg) $\Rightarrow \Delta t = \frac{84}{4200} = 0.02 \text{ k}$

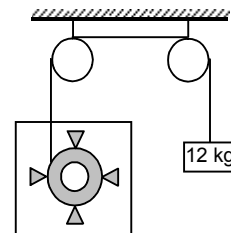

3. mass of block = 100 kg
 $u = 2 \text{ m/s}$, $m = 0.2$ $v = 0$
 $dQ = du + dw$
 In this case $dQ = 0$

$$\Rightarrow -du = dw \Rightarrow du = -\left(\frac{1}{2}mv^2 - \frac{1}{2}mu^2\right) = \frac{1}{2} \times 100 \times 2 \times 2 = 200 \text{ J}$$

4. $Q = 100 \text{ J}$

We know, $\Delta U = \Delta Q - \Delta W$

Here since the container is rigid, $\Delta V = 0$,

Hence the $\Delta W = P\Delta V = 0$,

So, $\Delta U = \Delta Q = 100 \text{ J}$.

5. $P_1 = 10 \text{ kpa} = 10 \times 10^3 \text{ pa}$. $P_2 = 50 \times 10^3 \text{ pa}$. $v_1 = 200 \text{ cc}$. $v_2 = 50 \text{ cc}$

(i) Work done on the gas = $\frac{1}{2}(10 + 50) \times 10^3 \times (50 - 200) \times 10^{-6} = -4.5 \text{ J}$

(ii) $dQ = 0 \Rightarrow 0 = du + dw \Rightarrow du = -dw = 4.5 \text{ J}$

6. initial State 'i' Final State 'f'

Given $\frac{P_1}{T_1} = \frac{P_2}{T_2}$

where $P_1 \rightarrow$ Initial Pressure ; $P_2 \rightarrow$ Final Pressure.

$T_2, T_1 \rightarrow$ Absolute temp. So, $\Delta V = 0$

Work done by gas = $P\Delta V = 0$

7. In path ACB,

$W_{AC} + W_{BC} = 0 + pdv = 30 \times 10^3 (25 - 10) \times 10^{-6} = 0.45 \text{ J}$

In path AB, $W_{AB} = \frac{1}{2} \times (10 + 30) \times 10^3 \times 15 \times 10^{-6} = 0.30 \text{ J}$

In path ADB, $W = W_{AD} + W_{DB} = 10 \times 10^3 (25 - 10) \times 10^{-6} + 0 = 0.15 \text{ J}$

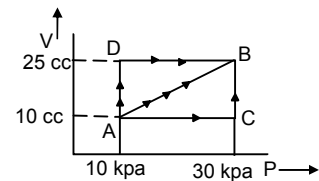

8. $\Delta Q = \Delta U + \Delta W$

In abc, $\Delta Q = 80 \text{ J}$ $\Delta W = 30 \text{ J}$

So, $\Delta U = (80 - 30) \text{ J} = 50 \text{ J}$

Now in adc, $\Delta W = 10 \text{ J}$

So, $\Delta Q = 10 + 50 = 60 \text{ J} [\therefore \Delta U = 50 \text{ J}]$

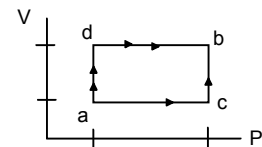

9. In path ACB,

$dQ = 50 \text{ J}$ $50 \times 4.2 = 210 \text{ J}$

$dW = W_{AC} + W_{CB} = 50 \times 10^3 \times 200 \times 10^{-6} = 10 \text{ J}$

$dQ = dU + dW$

$\Rightarrow dU = dQ - dW = 210 - 10 = 200 \text{ J}$

In path ADB, $dQ = ?$

$dU = 200 \text{ J}$ (Internal energy change between 2 points is always same)

$dW = W_{AD} + W_{DB} = 0 + 155 \times 10^3 \times 200 \times 10^{-6} = 31 \text{ J}$

$dQ = dU + dW = 200 + 31 = 231 \text{ J} = 55 \text{ cal}$

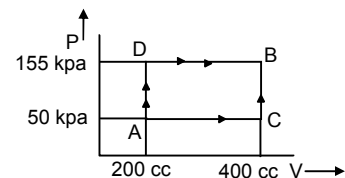

10. Heat absorbed = work done = Area under the graph

In the given case heat absorbed = area of the circle

$= \pi \times 10^4 \times 10^{-6} \times 10^3 = 3.14 \times 10 = 31.4 \text{ J}$

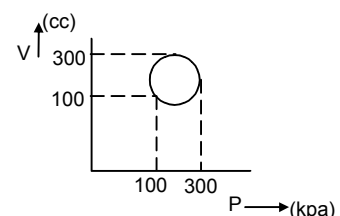

11. $dQ = 2.4 \text{ cal} = 2.4 \text{ J Joules}$

$dw = W_{AB} + W_{BC} + W_{AC}$

$= 0 + (1/2) \times (100 + 200) \times 10^3 \times 200 \times 10^{-6} - 100 \times 10^3 \times 200 \times 10^{-6}$
 $= (1/2) \times 300 \times 10^3 \times 200 \times 10^{-6} - 20 = 30 - 20 = 10 \text{ joules.}$

$du = 0$ (in a cyclic process)

$dQ = dU + dW \Rightarrow 2.4 \text{ J} = 10$

$\Rightarrow J = \frac{10}{2.4} \approx 4.17 \text{ J/Cal.}$

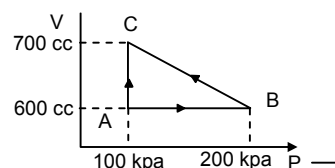

12. Now, $\Delta Q = (2625 \times J) \text{ J}$

$\Delta U = 5000 \text{ J}$

From Graph $\Delta W = 200 \times 10^3 \times 0.03 = 6000 \text{ J.}$

Now, $\Delta Q = \Delta W + \Delta U$

$\Rightarrow 2625 \text{ J} = 6000 + 5000 \text{ J}$

$J = \frac{11000}{2625} = 4.19 \text{ J/Cal}$

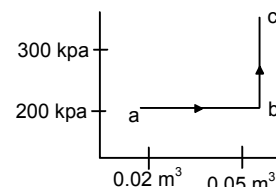

13. $dQ = 70 \text{ cal} = (70 \times 4.2) \text{ J}$

$dW = (1/2) \times (200 + 500) \times 10^3 \times 150 \times 10^{-6}$

$= (1/2) \times 500 \times 150 \times 10^{-3}$

$= 525 \times 10^{-1} = 52.5 \text{ J}$

$dU = ? \quad dQ = du + dw$

$\Rightarrow -294 = du + 52.5$

$\Rightarrow du = -294 - 52.5 = -346.5 \text{ J}$

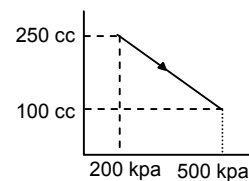

14. $U = 1.5 \text{ pV} \quad P = 1 \times 10^5 \text{ Pa}$

$dV = (200 - 100) \text{ cm}^3 = 100 \text{ cm}^3 = 10^{-4} \text{ m}^3$

$dU = 1.5 \times 10^5 \times 10^{-4} = 15$

$dW = 10^5 \times 10^{-4} = 10$

$dQ = dU + dW = 10 + 15 = 25 \text{ J}$

15. $dQ = 10 \text{ J}$

$dV = A \times 10 \text{ cm}^3 = 4 \times 10 \text{ cm}^3 = 40 \times 10^{-6} \text{ cm}^3$

$dw = Pdv = 100 \times 10^3 \times 40 \times 10^{-6} = 4 \text{ cm}^3$

$du = ? \quad 10 = du + dw \Rightarrow 10 = du + 4 \Rightarrow du = 6 \text{ J.}$

16. (a) $P_1 = 100 \text{ KPa}$

$V_1 = 2 \text{ m}^3$

$\Delta V_1 = 0.5 \text{ m}^3$

$\Delta P_1 = 100 \text{ KPa}$

From the graph, We find that area under AC is greater than area under AB. So, we see that heat is extracted from the system.

(b) Amount of heat = Area under ABC.

$= \frac{1}{2} \times \frac{5}{10} \times 10^5 = 25000 \text{ J}$

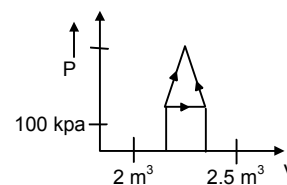

17. $n = 2 \text{ mole}$

$dQ = -1200 \text{ J}$

$dU = 0$ (During cyclic Process)

$dQ = dU + dW$

$\Rightarrow -1200 = W_{AB} + W_{BC} + W_{CA}$

$\Rightarrow -1200 = nR\Delta T + W_{BC} + 0$

$\Rightarrow -1200 = 2 \times 8.3 \times 200 + W_{BC}$

$\Rightarrow W_{BC} = -400 \times 8.3 - 1200 = -4520 \text{ J.}$

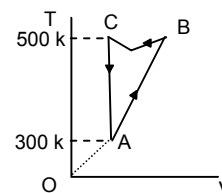

18. Given $n = 2$ moles

$$dV = 0$$

in ad and bc.

$$\text{Hence } dW = dQ$$

$$dW = dW_{ab} + dW_{cd}$$

$$= nRT_1 \ln \frac{2V_0}{V_0} + nRT_2 \ln \frac{V_0}{2V_0}$$

$$= nR \times 2.303 \times \log 2(500 - 300)$$

$$= 2 \times 8.314 \times 2.303 \times 0.301 \times 200 = 2305.31 \text{ J}$$

19. Given $M = 2 \text{ kg}$ $2t = 4^\circ\text{C}$ $S_w = 4200 \text{ J/Kg-k}$

$$f_0 = 999.9 \text{ kg/m}^3$$

$$f_4 = 1000 \text{ kg/m}^3$$

$$P = 10^5 \text{ Pa.}$$

Net internal energy = dv

$$dQ = dU + dw \Rightarrow ms\Delta Q\phi = dU + P(v_0 - v_4)$$

$$\Rightarrow 2 \times 4200 \times 4 = dU + 10^5(m - m)$$

$$\Rightarrow 33600 = dU + 10^5 \left(\frac{m}{V_0} - \frac{m}{V_4} \right) = dU + 10^5(0.0020002 - 0.002) = dU + 10^5 \cdot 0.0000002$$

$$\Rightarrow 33600 = du + 0.02 \Rightarrow du = (33600 - 0.02) \text{ J}$$

20. Mass = $10\text{g} = 0.01\text{kg}$.

$$P = 10^5 \text{ Pa}$$

$$dQ = Q_{\text{H}_2\text{O}} 0^\circ - 100^\circ + Q_{\text{H}_2\text{O}} - \text{steam}$$

$$= 0.01 \times 4200 \times 100 + 0.01 \times 2.5 \times 10^6 = 4200 + 25000 = 29200$$

$$dW = P \times \Delta V$$

$$\Delta = \frac{0.01}{0.6} - \frac{0.01}{1000} = 0.01699$$

$$dW = P\Delta V = 0.01699 \times 10^5 = 1699 \text{ J}$$

$$dQ = dW + dU \text{ or } dU = dQ - dW = 29200 - 1699 = 27501 = 2.75 \times 10^4 \text{ J}$$

21. (a) Since the wall can not be moved thus $dU = 0$ and $dQ = 0$.

Hence $dW = 0$.

- (b) Let final pressure in LHS = P_1

In RHS = P_2

(\therefore no. of mole remains constant)

$$\frac{P_1 V}{2RT_1} = \frac{P_1 V}{2RT}$$

$$\Rightarrow P_1 = \frac{P_1 T}{T_1} = \frac{P_1(P_1 + P_2)T_1 T_2}{\lambda}$$

$$\text{As, } T = \frac{(P_1 + P_2)T_1 T_2}{\lambda}$$

$$\text{Similarly } P_2 = \frac{P_2 T_1 (P_1 + P_2)}{\lambda}$$

- (c) Let $T_2 > T_1$ and 'T' be the common temp.

$$\text{Initially } \frac{P_1 V}{2} = n_1 r t_1 \Rightarrow n_1 = \frac{P_1 V}{2RT_1}$$

$$n_2 = \frac{P_2 V}{2RT_2} \text{ Hence } dQ = 0, dW = 0, \text{ Hence } dU = 0.$$

In case (LHS)

$$\Delta u_1 = 1.5n_1 R(T - T_1) \text{ But } \Delta u_1 - \Delta u_2 = 0$$

$$\Rightarrow 1.5 n_1 R(T - T_1) = 1.5 n_2 R(T_2 - T)$$

$$\Rightarrow n_2 T - n_1 T_1 = n_2 T_2 - n_2 T \Rightarrow T(n_1 + n_2) = n_1 T_1 + n_2 T_2$$

RHS

$$\Delta u_2 = 1.5n_2 R(T_2 - T)$$

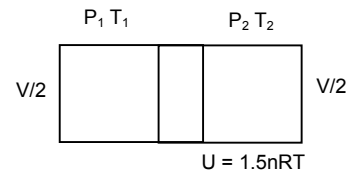
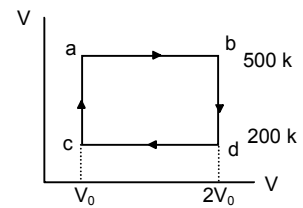

$$\Rightarrow T = \frac{n_1 T_1 + n_2 T_2}{n_1 + n_2}$$

$$= \frac{\frac{P_1 V}{2RT_1} \times T_1 + \frac{P_2 V}{2RT_2} \times T_2}{\frac{P_1 V}{2RT_1} + \frac{P_2 V}{2RT_2}} = \frac{P_1 T_2 + P_2 T_1}{T_1 T_2}$$

$$= \frac{(P_1 + P_2) T_1 T_2}{P_1 T_2 + P_2 T_1} = \frac{(P_1 + P_2) T_1 T_2}{\lambda} \text{ as } P_1 T_2 + P_2 T_1 = \lambda$$

(d) For RHS $dQ = dU$ (As $dW = 0$) $= 1.5 n_2 R(T_2 - t)$

$$= \frac{1.5 P_2 V}{2RT_2} R \left[\frac{T_2 - (P_1 - P_2) T_1 T_2}{P_1 T_2 - P_2 T_1} \right] = \frac{1.5 P_2 V}{2T_2} \left(\frac{P_1 T_2^2 - P_1 T_1 T_2}{\lambda} \right)$$

$$= \frac{1.5 P_2 V}{2T_2} \times \frac{T_2 P_1 (T_2 - T_1)}{\lambda} = \frac{3 P_1 P_2 (T_2 - T_1) V}{4 \lambda}$$

22. (a) As the conducting wall is fixed the work done by the gas on the left part during the process is Zero.

(b) For left side

Pressure = P

Volume = V

No. of moles = n(1mole)

Let initial Temperature = T_1

$$\frac{PV}{2} = nRT_1$$

$$\Rightarrow \frac{PV}{2} = (1)RT_1$$

$$\Rightarrow T_1 = \frac{PV}{2(\text{moles})R}$$

For right side

Let initial Temperature = T_2

$$\frac{PV}{2} = n_2 RT_2$$

$$\Rightarrow T_2 = \frac{PV}{2n_2 R} \times 1$$

$$\Rightarrow T_2 = \frac{PV}{4(\text{moles})R}$$

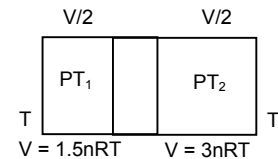

(c) Let the final Temperature = T

Final Pressure = R

No. of mole = 1 mole + 2 moles = 3 moles

$$\therefore PV = nRT \Rightarrow T = \frac{PV}{nR} = \frac{PV}{3(\text{mole})R}$$

(d) For RHS $dQ = dU$ [as, $dW = 0$]

$$= 1.5 n_2 R(T - T_2) = 1.5 \times 2 \times R \times \left[\frac{PV}{3(\text{mole})R} - \frac{PV}{4(\text{mole})R} \right]$$

$$= 1.5 \times 2 \times R \times \frac{4PV - 3PV}{4 \times 3(\text{mole})} = \frac{3 \times R \times PV}{3 \times 4 \times R} = \frac{PV}{4}$$

(e) As, $dQ = -dU$

$$\Rightarrow dU = -dQ = \frac{-PV}{4}$$

*** **

CHAPTER – 27
SPECIFIC HEAT CAPACITIES OF GASES

- $N = 1$ mole, $W = 20$ g/mol, $V = 50$ m/s
 K.E. of the vessel = Internal energy of the gas
 $= (1/2)mv^2 = (1/2) \times 20 \times 10^{-3} \times 50 \times 50 = 25$ J
 $25 = n \frac{3}{2} r(\Delta T) \Rightarrow 25 = 1 \times \frac{3}{2} \times 8.31 \times \Delta T \Rightarrow \Delta T = \frac{50}{3 \times 8.3} \approx 2$ k.
- $m = 5$ g, $\Delta t = 25 - 15 = 10^\circ\text{C}$
 $C_V = 0.172$ cal/g- $^\circ\text{C}$ = 4.2 J/Cal.
 $dQ = du + dw$
 Now, $V = 0$ (for a rigid body)
 So, $dw = 0$.
 So $dQ = du$.
 $Q = msdt = 5 \times 0.172 \times 10 = 8.6$ cal = $8.6 \times 4.2 = 36.12$ Joule.
- $\gamma = 1.4$, w or piston = 50 kg., A of piston = 100 cm²
 $P_o = 100$ kpa, $g = 10$ m/s², $x = 20$ cm.
 $dw = pdv = \left(\frac{mg}{A} + P_o \right) A dx = \left(\frac{50 \times 10}{100 \times 10^{-4}} + 10^5 \right) 100 \times 10^{-4} \times 20 \times 10^{-2} = 1.5 \times 10^5 \times 20 \times 10^{-4} = 300$ J.
 $nRdt = 300 \Rightarrow dT = \frac{300}{nR}$
 $dQ = nC_p dT = nC_p \times \frac{300}{nR} = \frac{n\gamma R 300}{(\gamma - 1)nR} = \frac{300 \times 1.4}{0.4} = 1050$ J.
- $C_V H_2 = 2.4$ Cal/g $^\circ\text{C}$, $C_p H^2 = 3.4$ Cal/g $^\circ\text{C}$
 $M = 2$ g/ Mol, $R = 8.3 \times 10^7$ erg/mol- $^\circ\text{C}$
 We know, $C_p - C_V = 1$ Cal/g $^\circ\text{C}$
 So, difference of molar specific heats
 $= C_p \times M - C_V \times M = 1 \times 2 = 2$ Cal/g $^\circ\text{C}$
 Now, $2 \times J = R \Rightarrow 2 \times J = 8.3 \times 10^7$ erg/mol- $^\circ\text{C} \Rightarrow J = 4.15 \times 10^7$ erg/cal.
- $\frac{C_p}{C_V} = 7.6$, $n = 1$ mole, $\Delta T = 50$ K
 (a) Keeping the pressure constant, $dQ = du + dw$,
 $\Delta T = 50$ K, $\gamma = 7/6$, $m = 1$ mole,
 $dQ = du + dw \Rightarrow nC_V dT = du + RdT \Rightarrow du = nC_p dT - RdT$
 $= 1 \times \frac{R\gamma}{\gamma - 1} \times dT - RdT = \frac{R \times \frac{7}{6}}{\frac{7}{6} - 1} dT - RdT$
 $= DT - RdT = 7RdT - RdT = 6RdT = 6 \times 8.3 \times 50 = 2490$ J.
 (b) Kipping Volume constant, $dv = nC_V dT$
 $= 1 \times \frac{R}{\gamma - 1} \times dt = \frac{1 \times 8.3}{\frac{7}{6} - 1} \times 50$
 $= 8.3 \times 50 \times 6 = 2490$ J
 (c) Adiabatically $dQ = 0$, $du = -dw$
 $= \left[\frac{n \times R}{\gamma - 1} (T_1 - T_2) \right] = \frac{1 \times 8.3}{\frac{7}{6} - 1} (T_2 - T_1) = 8.3 \times 50 \times 6 = 2490$ J

6. $m = 1.18 \text{ g}$, $V = 1 \times 10^3 \text{ cm}^3 = 1 \text{ L}$ $T = 300 \text{ k}$, $P = 10^5 \text{ Pa}$

$$PV = nRT \text{ or } n = \frac{PV}{RT} = 10^5 = \text{atm.}$$

$$N = \frac{PV}{RT} = \frac{1}{8.2 \times 10^{-2} \times 3 \times 10^2} = \frac{1}{8.2 \times 3} = \frac{1}{24.6}$$

$$\text{Now, } C_v = \frac{1}{n} \times \frac{Q}{dt} = 24.6 \times 2 = 49.2$$

$$C_p = R + C_v = 1.987 + 49.2 = 51.187$$

$$Q = nC_p dT = \frac{1}{24.6} \times 51.187 \times 1 = 2.08 \text{ Cal.}$$

7. $V_1 = 100 \text{ cm}^3$, $V_2 = 200 \text{ cm}^3$ $P = 2 \times 10^5 \text{ Pa}$, $\Delta Q = 50 \text{ J}$

$$(a) \Delta Q = du + dw \Rightarrow 50 = du + 20 \times 10^5 (200 - 100 \times 10^{-6}) \Rightarrow 50 = du + 20 \Rightarrow du = 30 \text{ J}$$

$$(b) 30 = n \times \frac{3}{2} \times 8.3 \times 300 \quad [U = \frac{3}{2} nRT \text{ for monoatomic}]$$

$$\Rightarrow n = \frac{2}{3 \times 83} = \frac{2}{249} = 0.008$$

$$(c) du = nC_v dT \Rightarrow C_v = \frac{dndTu}{0.008 \times 300} = \frac{30}{0.008 \times 300} = 12.5$$

$$C_p = C_v + R = 12.5 + 8.3 = 20.3$$

$$(d) C_v = 12.5 \text{ (Proved above)}$$

8. $Q = \text{Amt of heat given}$

$$\text{Work done} = \frac{Q}{2}, \quad \Delta Q = W + \Delta U$$

$$\text{for monoatomic gas } \Rightarrow \Delta U = Q - \frac{Q}{2} = \frac{Q}{2}$$

$$V = n \frac{3}{2} RT = \frac{Q}{2} = nT \times \frac{3}{2} R = 3R \times nT$$

$$\text{Again } Q = n C_p dT \text{ Where } C_p > \text{Molar heat capacity at const. pressure.}$$

$$3RnT = ndTC_p \Rightarrow C_p = 3R$$

9. $P = KV \Rightarrow \frac{nRT}{V} = KV \Rightarrow RT = KV^2 \Rightarrow R \Delta T = 2KV \Delta U \Rightarrow \frac{R \Delta T}{2KV} = dv$

$$dQ = du + dw \Rightarrow mcdT = C_v dT + pdv \Rightarrow msdT = C_v dT + \frac{PRdF}{2KV}$$

$$\Rightarrow ms = C_v + \frac{RKV}{2KV} \Rightarrow C_p + \frac{R}{2}$$

10. $\frac{C_p}{C_v} = \gamma$, $C_p - C_v = R$, $C_v = \frac{r}{\gamma - 1}$, $C_p = \frac{\gamma R}{\gamma - 1}$

$$PdV = \frac{1}{b+1} (Rdt)$$

$$\Rightarrow 0 = C_v dT + \frac{1}{b+1} (Rdt) \Rightarrow \frac{1}{b+1} = \frac{-C_v}{R}$$

$$\Rightarrow b + 1 = \frac{-R}{C_v} = \frac{-(C_p - C_v)}{C_v} = -\gamma + 1 \Rightarrow b = -\gamma$$

11. Considering two gases, in Gas(1) we have,

$$\gamma, C_{p1} \text{ (Sp. Heat at const. 'P')}, C_{v1} \text{ (Sp. Heat at const. 'V')}, n_1 \text{ (No. of moles)}$$

$$\frac{C_{p1}}{C_{v1}} = \gamma \text{ \& } C_{p1} - C_{v1} = R$$

$$\Rightarrow \gamma C_{V1} - C_{V1} = R \Rightarrow C_{V1} (\gamma - 1) = R$$

$$\Rightarrow C_{V1} = \frac{R}{\gamma - 1} \quad \& \quad C_{P1} = \frac{\gamma R}{\gamma - 1}$$

In Gas(2) we have, γ , C_{P2} (Sp. Heat at const. 'P'), C_{V2} (Sp. Heat at const. 'V'), n_2 (No. of moles)

$$\frac{C_{P2}}{C_{V2}} = \gamma \quad \& \quad C_{P2} - C_{V2} = R \Rightarrow \gamma C_{V2} - C_{V2} = R \Rightarrow C_{V2} (\gamma - 1) = R \Rightarrow C_{V2} = \frac{R}{\gamma - 1} \quad \& \quad C_{P2} = \frac{\gamma R}{\gamma - 1}$$

Given $n_1 : n_2 = 1 : 2$

$$dU_1 = nC_{V1} dT \quad \& \quad dU_2 = 2nC_{V2} dT = 3nC_{Vd}dT$$

$$\Rightarrow C_V = \frac{C_{V1} + 2C_{V2}}{3} = \frac{\frac{R}{\gamma-1} + \frac{2R}{\gamma-1}}{3} = \frac{3R}{3(\gamma-1)} = \frac{R}{\gamma-1} \quad \dots(1)$$

$$\& C_P = \gamma C_V = \frac{\gamma R}{\gamma-1} \quad \dots(2)$$

$$\text{So, } \frac{C_P}{C_V} = \gamma \text{ [from (1) \& (2)]}$$

12. $C_{P'} = 2.5 R$ $C_{P''} = 3.5 R$

$$C_{V'} = 1.5 R \quad C_{V''} = 2.5 R$$

$$n_1 = n_2 = 1 \text{ mol} \quad (n_1 + n_2)C_V dT = n_1 C_{V'} dT + n_2 C_{V''} dT$$

$$\Rightarrow C_V = \frac{n_1 C_{V'} + n_2 C_{V''}}{n_1 + n_2} = \frac{1.5R + 2.5R}{2} = 2R$$

$$C_P = C_V + R = 2R + R = 3R$$

$$\gamma = \frac{C_P}{C_V} = \frac{3R}{2R} = 1.5$$

13. $n = \frac{1}{2}$ mole, $R = \frac{25}{3}$ J/mol-k, $\gamma = \frac{5}{3}$

(a) Temp at A = T_a , $P_a V_a = nRT_a$

$$\Rightarrow T_a = \frac{P_a V_a}{nR} = \frac{5000 \times 10^{-6} \times 100 \times 10^3}{\frac{1}{2} \times \frac{25}{3}} = 120 \text{ k.}$$

Similarly temperatures at point b = 240 k at C it is 480 k and at D it is 240 k.

(b) For ab process,

$$dQ = nC_P dT \quad \text{[since ab is isobaric]}$$

$$= \frac{1}{2} \times \frac{R\gamma}{\gamma-1} (T_b - T_a) = \frac{1}{2} \times \frac{\frac{35}{5} \times \frac{5}{3}}{\frac{5}{3}-1} \times (240 - 120) = \frac{1}{2} \times \frac{125}{9} \times \frac{3}{2} \times 120 = 1250 \text{ J}$$

For bc, $dQ = du + dw$ [dq = 0, Isochoric process]

$$\Rightarrow dQ = du = nC_V dT = \frac{nR}{\gamma-1} (T_c - T_a) = \frac{1}{2} \times \frac{\frac{25}{3}}{\left(\frac{5}{3}-1\right)} (240) = \frac{1}{2} \times \frac{25}{3} \times \frac{3}{2} \times 240 = 1500 \text{ J}$$

(c) Heat liberated in cd = $-nC_P dT$

$$= \frac{-1}{2} \times \frac{nR}{\gamma-1} (T_d - T_c) = \frac{-1}{2} \times \frac{125}{3} \times \frac{3}{2} \times 240 = 2500 \text{ J}$$

Heat liberated in da = $-nC_V dT$

$$= \frac{-1}{2} \times \frac{R}{\gamma-1} (T_a - T_d) = \frac{-1}{2} \times \frac{25}{2} \times (120 - 240) = 750 \text{ J}$$

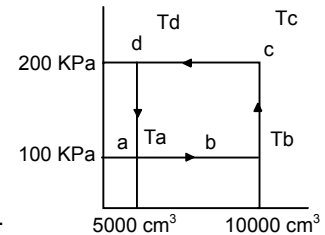

14. (a) For a, b 'V' is constant

$$\text{So, } \frac{P_1}{T_1} = \frac{P_2}{T_2} \Rightarrow \frac{100}{300} = \frac{200}{T_2} \Rightarrow T_2 = \frac{200 \times 300}{100} = 600 \text{ k}$$

For b,c 'P' is constant

$$\text{So, } \frac{V_1}{T_1} = \frac{V_2}{T_2} \Rightarrow \frac{100}{600} = \frac{150}{T_2} \Rightarrow T_2 = \frac{600 \times 150}{100} = 900 \text{ k}$$

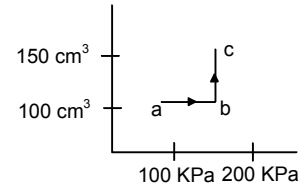

(b) Work done = Area enclosed under the graph $50 \text{ cc} \times 200 \text{ kPa} = 50 \times 10^{-6} \times 200 \times 10^3 \text{ J} = 10 \text{ J}$

(c) 'Q' Supplied = $nC_v dT$

$$\text{Now, } n = \frac{PV}{RT} \text{ considering at pt. 'b'}$$

$$C_v = \frac{R}{\gamma - 1} dT = 300 \text{ a, b.}$$

$$Q_{bc} = \frac{PV}{RT} \times \frac{R}{\gamma - 1} dT = \frac{200 \times 10^3 \times 100 \times 10^{-6}}{600 \times 0.67} \times 300 = 14.925 \quad (\because \gamma = 1.67)$$

$$Q \text{ supplied to be } nC_p dT \quad [\because C_p = \frac{\gamma R}{\gamma - 1}]$$

$$= \frac{PV}{RT} \times \frac{\gamma R}{\gamma - 1} dT = \frac{200 \times 10^3 \times 150 \times 10^{-6}}{8.3 \times 900} \times \frac{1.67 \times 8.3}{0.67} \times 300 = 24.925$$

(d) $Q = \Delta U + w$

$$\text{Now, } \Delta U = Q - w = \text{Heat supplied} - \text{Work done} = (24.925 + 14.925) - 1 = 29.850$$

15. In Joly's differential steam calorimeter

$$C_v = \frac{m_2 L}{m_1(\theta_2 - \theta_1)}$$

$$m_2 = \text{Mass of steam condensed} = 0.095 \text{ g, } L = 540 \text{ Cal/g} = 540 \times 4.2 \text{ J/g}$$

$$m_1 = \text{Mass of gas present} = 3 \text{ g, } \theta_1 = 20^\circ\text{C, } \theta_2 = 100^\circ\text{C}$$

$$\Rightarrow C_v = \frac{0.095 \times 540 \times 4.2}{3(100 - 20)} = 0.89 \approx 0.9 \text{ J/g-K}$$

16. $\gamma = 1.5$

Since it is an adiabatic process, So $PV^\gamma = \text{const.}$

$$(a) P_1 V_1^\gamma = P_2 V_2^\gamma \quad \text{Given } V_1 = 4 \text{ L, } V_2 = 3 \text{ L, } \frac{P_2}{P_1} = ?$$

$$\Rightarrow \frac{P_2}{P_1} = \left(\frac{V_1}{V_2}\right)^\gamma = \left(\frac{4}{3}\right)^{1.5} = 1.5396 \approx 1.54$$

(b) $TV^{\gamma-1} = \text{Const.}$

$$T_1 V_1^{\gamma-1} = T_2 V_2^{\gamma-1} \Rightarrow \frac{T_2}{T_1} = \left(\frac{V_1}{V_2}\right)^{\gamma-1} = \left(\frac{4}{3}\right)^{0.5} = 1.154$$

17. $P_1 = 2.5 \times 10^5 \text{ Pa, } V_1 = 100 \text{ cc, } T_1 = 300 \text{ k}$

$$(a) P_1 V_1^\gamma = P_2 V_2^\gamma$$

$$\Rightarrow 2.5 \times 10^5 \times V^{1.5} = \left(\frac{V}{2}\right)^{1.5} \times P_2$$

$$\Rightarrow P_2 = 2^{1.5} \times 2.5 \times 10^5 = 7.07 \times 10^5 \approx 7.1 \times 10^5$$

$$(b) T_1 V_1^{\gamma-1} = T_2 V_2^{\gamma-1} \Rightarrow 300 \times (100)^{1.5-1} = T_2 \times (50)^{1.5-1}$$

$$\Rightarrow T_2 = \frac{3000}{7.07} = 424.32 \text{ k} \approx 424 \text{ k}$$

(c) Work done by the gas in the process

$$W = \frac{mR}{\gamma-1} [T_2 - T_1] = \frac{P_1 V_1}{T(\gamma-1)} [T_2 - T_1]$$

$$= \frac{2.5 \times 10^5 \times 100 \times 10^{-6}}{300(1.5-1)} [424 - 300] = \frac{2.5 \times 10}{300 \times 0.5} \times 124 = 20.72 \approx 21 \text{ J}$$

18. $\gamma = 1.4$, $T_1 = 20^\circ\text{C} = 293 \text{ k}$, $P_1 = 2 \text{ atm}$, $p_2 = 1 \text{ atm}$

We know for adiabatic process,

$$P_1^{1-\gamma} \times T_1^\gamma = P_2^{1-\gamma} \times T_2^\gamma \text{ or } (2)^{1-1.4} \times (293)^{1.4} = (1)^{1-1.4} \times T_2^{1.4}$$

$$\Rightarrow (2)^{0.4} \times (293)^{1.4} = T_2^{1.4} \Rightarrow 2153.78 = T_2^{1.4} \Rightarrow T_2 = (2153.78)^{1/1.4} = 240.3 \text{ K}$$

19. $P_1 = 100 \text{ KPa} = 10^5 \text{ Pa}$, $V_1 = 400 \text{ cm}^3 = 400 \times 10^{-6} \text{ m}^3$, $T_1 = 300 \text{ k}$,

$$\gamma = \frac{C_P}{C_V} = 1.5$$

(a) Suddenly compressed to $V_2 = 100 \text{ cm}^3$

$$P_1 V_1^\gamma = P_2 V_2^\gamma \Rightarrow 10^5 (400)^{1.5} = P_2 \times (100)^{1.5}$$

$$\Rightarrow P_2 = 10^5 \times (4)^{1.5} = 800 \text{ KPa}$$

$$T_1 V_1^{\gamma-1} = T_2 V_2^{\gamma-1} \Rightarrow 300 \times (400)^{1.5-1} = T_2 \times (100)^{1.5-1} \Rightarrow T_2 = \frac{300 \times 20}{10} = 600 \text{ K}$$

(b) Even if the container is slowly compressed the walls are adiabatic so heat transferred is 0.

Thus the values remain, $P_2 = 800 \text{ KPa}$, $T_2 = 600 \text{ K}$.

20. Given $\frac{C_P}{C_V} = \gamma$ P_0 (Initial Pressure), V_0 (Initial Volume)

(a) (i) Isothermal compression, $P_1 V_1 = P_2 V_2$ or, $P_0 V_0 = \frac{P_2 V_0}{2} \Rightarrow P_2 = 2P_0$

(ii) Adiabatic Compression $P_1 V_1^\gamma = P_2 V_2^\gamma$ or $2P_0 \left(\frac{V_0}{2}\right)^\gamma = P_1 \left(\frac{V_0}{4}\right)^\gamma$

$$\Rightarrow P' = \frac{V_0^\gamma}{2^\gamma} \times 2P_0 \times \frac{4^\gamma}{V_0^\gamma} = 2^\gamma \times 2 P_0 \Rightarrow P_0 2^{\gamma+1}$$

(b) (i) Adiabatic compression $P_1 V_1^\gamma = P_2 V_2^\gamma$ or $P_0 V_0^\gamma = P' \left(\frac{V_0}{2}\right)^\gamma \Rightarrow P' = P_0 2^\gamma$

(ii) Isothermal compression $P_1 V_1 = P_2 V_2$ or $2^\gamma P_0 \times \frac{V_0}{2} = P_2 \times \frac{V_0}{4} \Rightarrow P_2 = P_0 2^{\gamma+1}$

21. Initial pressure = P_0

Initial Volume = V_0

$$\gamma = \frac{C_P}{C_V}$$

(a) Isothermally to pressure $\frac{P_0}{2}$

$$P_0 V_0 = \frac{P_0}{2} V_1 \Rightarrow V_1 = 2 V_0$$

Adiabatically to pressure = $\frac{P_0}{4}$

$$\frac{P_0}{2} (V_1)^\gamma = \frac{P_0}{4} (V_2)^\gamma \Rightarrow \frac{P_0}{2} (2V_0)^\gamma = \frac{P_0}{4} (V_2)^\gamma$$

$$\Rightarrow 2^{\gamma+1} V_0^\gamma = V_2^\gamma \Rightarrow V_2 = 2^{(\gamma+1)/\gamma} V_0$$

$$\therefore \text{Final Volume} = 2^{(\gamma+1)/\gamma} V_0$$

(b) Adiabatically to pressure $\frac{P_0}{2}$ to P_0

$$P_0 \times (2^{\gamma+1} V_0^\gamma) = \frac{P_0}{2} \times (V')^\gamma$$

Isothermal to pressure $\frac{P_0}{4}$

$$\frac{P_0}{2} \times 2^{1/\gamma} V_0 = \frac{P_0}{4} \times V'' \Rightarrow V'' = 2^{(\gamma+1)/\gamma} V_0$$

$$\therefore \text{Final Volume} = 2^{(\gamma+1)/\gamma} V_0$$

22. $PV = nRT$

Given $P = 150 \text{ KPa} = 150 \times 10^3 \text{ Pa}$, $V = 150 \text{ cm}^3 = 150 \times 10^{-6} \text{ m}^3$, $T = 300 \text{ K}$

(a) $n = \frac{PV}{RT} = \frac{150 \times 10^3 \times 150 \times 10^{-6}}{8.3 \times 300} = 9.036 \times 10^{-3} = 0.009 \text{ moles.}$

(b) $\frac{C_P}{C_V} = \gamma \Rightarrow \frac{\gamma R}{(\gamma-1)C_V} = \gamma \quad \left[\therefore C_P = \frac{\gamma R}{\gamma-1} \right]$

$$\Rightarrow C_V = \frac{R}{\gamma-1} = \frac{8.3}{1.5-1} = \frac{8.3}{0.5} = 2R = 16.6 \text{ J/mole}$$

(c) Given $P_1 = 150 \text{ KPa} = 150 \times 10^3 \text{ Pa}$, $P_2 = ?$

$$V_1 = 150 \text{ cm}^3 = 150 \times 10^{-6} \text{ m}^3, \quad \gamma = 1.5$$

$$V_2 = 50 \text{ cm}^3 = 50 \times 10^{-6} \text{ m}^3, \quad T_1 = 300 \text{ K}, \quad T_2 = ?$$

Since the process is adiabatic Hence $-P_1 V_1^\gamma = P_2 V_2^\gamma$

$$\Rightarrow 150 \times 10^3 (150 \times 10^{-6})^\gamma = P_2 \times (50 \times 10^{-6})^\gamma$$

$$\Rightarrow P_2 = 150 \times 10^3 \times \left(\frac{150 \times 10^{-6}}{50 \times 10^{-6}} \right)^{1.5} = 150000 \times 3^{1.5} = 779.422 \times 10^3 \text{ Pa} \approx 780 \text{ KPa}$$

(d) $\Delta Q = W + \Delta U$ or $W = -\Delta U$ [$\therefore \Delta U = 0$, in adiabatic]

$$= -nC_V dT = -0.009 \times 16.6 \times (520 - 300) = -0.009 \times 16.6 \times 220 = -32.8 \text{ J} \approx -33 \text{ J}$$

(e) $\Delta U = nC_V dT = 0.009 \times 16.6 \times 220 \approx 33 \text{ J}$

23. $V_A = V_B = V_C$

For A, the process is isothermal

$$P_A V_A = P_A' V_A' \Rightarrow P_A' = P_A \frac{V_A}{V_A'} = P_A \times \frac{1}{2}$$

For B, the process is adiabatic,

$$P_A (V_B)^\gamma = P_A' (V_B)^\gamma = P_B' = P_B \left(\frac{V_B}{V_B'} \right)^\gamma = P_B \times \left(\frac{1}{2} \right)^{1.5} = \frac{P_B}{2^{1.5}}$$

For, C, the process is isobaric

$$\frac{V_C}{T_C} = \frac{V_C'}{T_C'} \Rightarrow \frac{V_C}{T_C} = \frac{2V_C'}{T_C'} \Rightarrow T_C' = \frac{2}{T_C}$$

Final pressures are equal.

$$= \frac{P_A}{2} = \frac{P_B}{2^{1.5}} = P_C \Rightarrow P_A : P_B : P_C = 2 : 2^{1.5} : 1 = 2 : 2\sqrt{2} : 1$$

24. $P_1 = \text{Initial Pressure}$ $V_1 = \text{Initial Volume}$ $P_2 = \text{Final Pressure}$ $V_2 = \text{Final Volume}$

Given, $V_2 = 2V_1$, Isothermal workdone = $nRT_1 \ln \left(\frac{V_2}{V_1} \right)$

$$\text{Adiabatic workdone} = \frac{P_1 V_1 - P_2 V_2}{\gamma - 1}$$

Given that workdone in both cases is same.

$$\text{Hence } nRT_1 \ln\left(\frac{V_2}{V_1}\right) = \frac{P_1 V_1 - P_2 V_2}{\gamma - 1} \Rightarrow (\gamma - 1) \ln\left(\frac{V_2}{V_1}\right) = \frac{P_1 V_1 - P_2 V_2}{nRT_1}$$

$$\Rightarrow (\gamma - 1) \ln\left(\frac{V_2}{V_1}\right) = \frac{nRT_1 - nRT_2}{nRT_1} \Rightarrow (\gamma - 1) \ln 2 = \frac{T_1 - T_2}{T_1} \quad \dots(i) \quad [\because V_2 = 2V_1]$$

We know $TV^{\gamma-1} = \text{const.}$ in adiabatic Process.

$$T_1 V_1^{\gamma-1} = T_2 V_2^{\gamma-1}, \text{ or } T_1 (V_2)^{\gamma-1} = T_2 \times (2)^{\gamma-1} \times (V_1)^{\gamma-1}$$

$$\text{Or, } T_1 = 2^{\gamma-1} \times T_2 \text{ or } T_2 = T_1^{1-\gamma} \quad \dots(ii)$$

From (i) & (ii)

$$(\gamma - 1) \ln 2 = \frac{T_1 - T_1 \times 2^{1-\gamma}}{T_1} \Rightarrow (\gamma - 1) \ln 2 = 1 - 2^{1-\gamma}$$

25. $\gamma = 1.5, \quad T = 300 \text{ k}, \quad V = 1 \text{ L} = \frac{1}{2} \text{ m}^3$

(a) The process is adiabatic as it is sudden,

$$P_1 V_1^\gamma = P_2 V_2^\gamma \Rightarrow P_1 (V_0)^\gamma = P_2 \left(\frac{V_0}{2}\right)^\gamma \Rightarrow P_2 = P_1 \left(\frac{1}{1/2}\right)^{1.5} = P_1 (2)^{1.5} \Rightarrow \frac{P_2}{P_1} = 2^{1.5} = 2\sqrt{2}$$

$$(b) P_1 = 100 \text{ KPa} = 10^5 \text{ Pa} \quad W = \frac{nR}{\gamma - 1} [T_1 - T_2]$$

$$T_1 V_1^{\gamma-1} = P_2 V_2^{\gamma-1} \Rightarrow 300 \times (1)^{1.5-1} = T_2 (0.5)^{1.5-1} \Rightarrow 300 \times 1 = T_2 \sqrt{0.5}$$

$$T_2 = 300 \times \sqrt{\frac{1}{0.5}} = 300\sqrt{2} \text{ K}$$

$$P_1 V_1 = nRT_1 \Rightarrow n = \frac{P_1 V_1}{RT_1} = \frac{10^5 \times 10^{-3}}{R \times 300} = \frac{1}{3R} \quad (V \text{ in m}^3)$$

$$w = \frac{nR}{\gamma - 1} [T_1 - T_2] = \frac{1R}{3R(1.5 - 1)} [300 - 300\sqrt{2}] = \frac{300}{3 \times 0.5} (1 - \sqrt{2}) = -82.8 \text{ J} \approx -82 \text{ J.}$$

(c) Internal Energy,

$$dQ = 0, \quad \Rightarrow du = -dw = -(-82.8) \text{ J} = 82.8 \text{ J} \approx 82 \text{ J.}$$

(d) Final Temp = $300\sqrt{2} = 300 \times 1.414 \times 100 = 424.2 \text{ k} \approx 424 \text{ k.}$

(e) The pressure is kept constant. \therefore The process is isobaric.

$$\text{Work done} = nRdT = \frac{1}{3R} \times R \times (300 - 300\sqrt{2}) \quad \text{Final Temp} = 300 \text{ K}$$

$$= -\frac{1}{3} \times 300 (0.414) = -41.4 \text{ J. Initial Temp} = 300\sqrt{2}$$

$$(f) \text{ Initial volume} \Rightarrow \frac{V_1}{T_1} = \frac{V_1'}{T_1'} = V_1' = \frac{V_1}{T_1} \times T_1' = \frac{1}{2 \times 300 \times \sqrt{2}} \times 300 = \frac{1}{2\sqrt{2}} \text{ L.}$$

Final volume = 1L

$$\text{Work done in isothermal} = nRT \ln \frac{V_2}{V_1}$$

$$= \frac{1}{3R} \times R \times 300 \ln\left(\frac{1}{1/2\sqrt{2}}\right) = 100 \times \ln(2\sqrt{2}) = 100 \times 1.039 \approx 103$$

$$(g) \text{ Net work done} = W_A + W_B + W_C = -82 - 41.4 + 103 = -20.4 \text{ J.}$$

26. Given $\gamma = 1.5$

We know from adiabatic process $TV^{\gamma-1} = \text{Const.}$

So, $T_1 V_1^{\gamma-1} = T_2 V_2^{\gamma-1}$... (eq)

As, it is an adiabatic process and all the other conditions are same. Hence the above equation can be applied.

So, $T_1 \times \left(\frac{3V}{4}\right)^{1.5-1} = T_2 \times \left(\frac{V}{4}\right)^{1.5-1} \Rightarrow T_1 \times \left(\frac{3V}{4}\right)^{0.5} = T_2 \times \left(\frac{V}{4}\right)^{0.5}$

$\Rightarrow \frac{T_1}{T_2} = \left(\frac{V}{4}\right)^{0.5} \times \left(\frac{4}{3V}\right)^{0.5} = \frac{1}{\sqrt{3}}$ So, $T_1 : T_2 = 1 : \sqrt{3}$

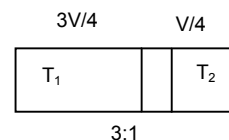
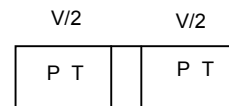

27. $V = 200 \text{ cm}^3$, $C = 12.5 \text{ J/mol-k}$, $T = 300 \text{ k}$, $P = 75 \text{ cm}$

(a) No. of moles of gas in each vessel,

$\frac{PV}{RT} = \frac{75 \times 13.6 \times 980 \times 200}{8.3 \times 10^7 \times 300} = 0.008$

(b) Heat is supplied to the gas but $dv = 0$

$dQ = du \Rightarrow 5 = nC_v dT \Rightarrow 5 = 0.008 \times 12.5 \times dT \Rightarrow dT = \frac{5}{0.008 \times 12.5}$ for (A)

For (B) $dT = \frac{10}{0.008 \times 12.5}$ $\therefore \frac{P}{T} = \frac{P_A}{T_A}$ [For container A]

$\Rightarrow \frac{75}{300} = \frac{P_A \times 0.008 \times 12.5}{5} \Rightarrow P_A = \frac{75 \times 5}{300 \times 0.008 \times 12.5} = 12.5 \text{ cm of Hg.}$

$\therefore \frac{P}{T} = \frac{P_B}{T_B}$ [For Container B] $\Rightarrow \frac{75}{300} = \frac{P_B \times 0.008 \times 12.5}{10} \Rightarrow P_B = 2 P_A = 25 \text{ cm of Hg.}$

Mercury moves by a distance $P_B - P_A = 25 - 12.5 = 12.5 \text{ Cm.}$

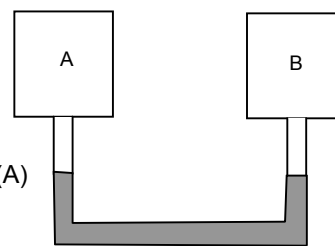

28. $m_{\text{He}} = 0.1 \text{ g}$, $\gamma = 1.67$, $\mu = 4 \text{ g/mol}$, $m_{\text{H}_2} = ?$

$\mu = 28/\text{mol}$ $\gamma_2 = 1.4$

Since it is an adiabatic surrounding

He $dQ = nC_v dT = \frac{0.1}{4} \times \frac{R}{\gamma-1} \times dT = \frac{0.1}{4} \times \frac{R}{(1.67-1)} \times dT$... (i)

$\text{H}_2 = nC_v dT = \frac{m}{2} \times \frac{R}{\gamma-1} \times dT = \frac{m}{2} \times \frac{R}{1.4-1} \times dT$ [Where m is the reqd.]

Mass of H_2

Since equal amount of heat is given to both and ΔT is same in both.

Equating (i) & (ii) we get

$\frac{0.1}{4} \times \frac{R}{0.67} \times dT = \frac{m}{2} \times \frac{R}{0.4} \times dT \Rightarrow m = \frac{0.1}{2} \times \frac{0.4}{0.67} = 0.0298 \approx 0.03 \text{ g}$

29. Initial pressure = P_0 , Initial Temperature = T_0

Initial Volume = V_0

$\frac{C_p}{C_v} = \gamma$

(a) For the diathermic vessel the temperature inside remains constant

$P_1 V_1 = P_2 V_2 \Rightarrow P_0 V_0 = P_2 \times 2V_0 \Rightarrow P_2 = \frac{P_0}{2}$, Temperature = T_0

For adiabatic vessel the temperature does not remains constant. The process is adiabatic

$T_1 V_1^{\gamma-1} = T_2 V_2^{\gamma-1} \Rightarrow T_0 V_0^{\gamma-1} = T_2 \times (2V_0)^{\gamma-1} \Rightarrow T_2 = T_0 \left(\frac{V_0}{2V_0}\right)^{\gamma-1} = T_0 \times \left(\frac{1}{2}\right)^{\gamma-1} = \frac{T_0}{2^{\gamma-1}}$

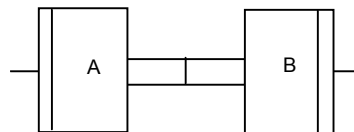

$$P_1 V_1^\gamma = P_2 V_2^\gamma \Rightarrow P_0 V_0^\gamma = p_1 (2V_0)^\gamma \Rightarrow P_1 = P_0 \left(\frac{V_0}{2V_0} \right)^\gamma = \frac{P_0}{2^\gamma}$$

(b) When the values are opened, the temperature remains T_0 through out

$$P_1 = \frac{n_1 RT_0}{4V_0}, P_2 = \frac{n_2 RT_0}{4V_0} \text{ [Total value after the expt} = 2V_0 + 2V_0 = 4V_0]$$

$$P = P_1 + P_2 = \frac{(n_1 + n_2)RT_0}{4V_0} = \frac{2nRT_0}{4V_0} = \frac{nRT_0}{2V} = \frac{P_0}{2}$$

30. For an adiabatic process, $PV^\gamma = \text{Const.}$

There will be a common pressure 'P' when the equilibrium is reached

$$\text{Hence } P_1 \left(\frac{V_0}{2} \right)^\gamma = P(V')^\gamma$$

$V_0/2$	$V_0/2$
$P_1 T_1$	$P_2 T_2$

$$\text{For left } P = P_1 \left(\frac{V_0}{2} \right)^\gamma (V')^\gamma \dots(1)$$

$$\text{For Right } P = P_2 \left(\frac{V_0}{2} \right)^\gamma (V_0 - V')^\gamma \dots(2)$$

V'	$V_0 - V'$
1	

Equating 'P' for both left & right

$$= \frac{P_1}{(V')^\gamma} = \frac{P_2}{(V_0 - V')^\gamma} \text{ or } \frac{V_0 - V'}{V'} = \left(\frac{P_2}{P_1} \right)^{1/\gamma}$$

$$\Rightarrow \frac{V_0}{V'} - 1 = \frac{P_2^{1/\gamma}}{P_1^{1/\gamma}} \Rightarrow \frac{V_0}{V'} = \frac{P_2^{1/\gamma} + P_1^{1/\gamma}}{P_1^{1/\gamma}} \Rightarrow V' = \frac{V_0 P_1^{1/\gamma}}{P_1^{1/\gamma} + P_2^{1/\gamma}} \text{ For left(3)}$$

$$\text{Similarly } V_0 - V' = \frac{V_0 P_2^{1/\gamma}}{P_1^{1/\gamma} + P_2^{1/\gamma}} \text{ For right(4)}$$

(b) Since the whole process takes place in adiabatic surroundings. The separator is adiabatic. Hence heat given to the gas in the left part = Zero.

$$\text{(c) From (1) Final pressure } P = \frac{P_1 \left(\frac{V_0}{2} \right)^\gamma}{(V')^\gamma}$$

$$\text{Again from (3) } V' = \frac{V_0 P_1^{1/\gamma}}{P_1^{1/\gamma} + P_2^{1/\gamma}} \text{ or } P = \frac{P_1 \left(\frac{V_0}{2} \right)^\gamma}{\left(\frac{V_0 P_1^{1/\gamma}}{P_1^{1/\gamma} + P_2^{1/\gamma}} \right)^\gamma} = \frac{P_1 (V_0)^\gamma}{2^\gamma} \times \frac{(P_1^{1/\gamma} + P_2^{1/\gamma})^\gamma}{(V_0)^\gamma P_1} = \left(\frac{P_1^{1/\gamma} + P_2^{1/\gamma}}{2} \right)^\gamma$$

31. $A = 1 \text{ cm}^2 = 1 \times 10^{-4} \text{ m}^2$, $M = 0.03 \text{ g} = 0.03 \times 10^{-3} \text{ kg}$,

$P = 1 \text{ atm} = 10^5 \text{ pascal}$, $L = 40 \text{ cm} = 0.4 \text{ m}$.

$L_1 = 80 \text{ cm} = 0.8 \text{ m}$, $P = 0.355 \text{ atm}$

The process is adiabatic

$$P(V)^\gamma = P(V')^\gamma \Rightarrow 1 \times (AL)^\gamma = 0.355 \times (A2L)^\gamma \Rightarrow 1 = 0.355 \cdot 2^\gamma \Rightarrow \frac{1}{0.355} = 2^\gamma$$

$$= \gamma \log 2 = \log \left(\frac{1}{0.355} \right) = 1.4941$$

$$V = \sqrt{\frac{\gamma P}{f}} = \sqrt{\frac{1.4941 \times 10^5}{\text{m/v}}} = \sqrt{\frac{1.4941 \times 10^5}{\left(\frac{0.03 \times 10^{-3}}{10^{-4} \times 1 \times 0.4} \right)^\gamma}} = \sqrt{\frac{1.441 \times 10^5 \times 4 \times 10^{-5}}{3 \times 10^{-5}}} = 446.33 \approx 447 \text{ m/s}$$

32. $V = 1280 \text{ m/s}$, $T = 0^\circ\text{C}$, $f_0\text{H}_2 = 0.089 \text{ kg/m}^3$, $rR = 8.3 \text{ J/mol-k}$,
At STP, $P = 10^5 \text{ Pa}$, We know

$$V_{\text{sound}} = \sqrt{\frac{\gamma P}{f_0}} \Rightarrow 1280 = \sqrt{\frac{\gamma \times 10^5}{0.089}} \Rightarrow (1280)^2 = \frac{\gamma \times 10^5}{0.089} \Rightarrow \gamma = \frac{0.089 \times (1280)^2}{10^5} \approx 1.458$$

Again,

$$C_V = \frac{R}{\gamma - 1} = \frac{8.3}{1.458 - 1} = 18.1 \text{ J/mol-k}$$

Again, $\frac{C_P}{C_V} = \gamma$ or $C_P = \gamma C_V = 1.458 \times 18.1 = 26.3 \text{ J/mol-k}$

33. $\mu = 4g = 4 \times 10^{-3} \text{ kg}$, $V = 22400 \text{ cm}^3 = 22400 \times 10^{-6} \text{ m}^3$
 $C_P = 5 \text{ cal/mol-ki} = 5 \times 4.2 \text{ J/mol-k} = 21 \text{ J/mol-k}$

$$C_P = \frac{\gamma R}{\gamma - 1} = \frac{\gamma \times 8.3}{\gamma - 1}$$

$$\Rightarrow 21(\gamma - 1) = \gamma(8.3) \Rightarrow 21\gamma - 21 = 8.3\gamma \Rightarrow \gamma = \frac{21}{12.7}$$

Since the condition is STP, $P = 1 \text{ atm} = 10^5 \text{ pa}$

$$V = \sqrt{\frac{\gamma f}{f}} = \sqrt{\frac{\frac{21}{12.7} \times 10^5}{4 \times 10^{-3}}} = \sqrt{\frac{21 \times 10^5 \times 22400 \times 10^{-6}}{12.7 \times 4 \times 10^{-3}}} = 962.28 \text{ m/s}$$

34. Given $f_0 = 1.7 \times 10^{-3} \text{ g/cm}^3 = 1.7 \text{ kg/m}^3$, $P = 1.5 \times 10^5 \text{ Pa}$, $R = 8.3 \text{ J/mol-k}$,
 $f = 3.0 \text{ KHz}$.

Node separation in a Kundt's tube = $\frac{\lambda}{2} = 6 \text{ cm}$, $\Rightarrow \lambda = 12 \text{ cm} = 12 \times 10^{-3} \text{ m}$

So, $V = f\lambda = 3 \times 10^3 \times 12 \times 10^{-2} = 360 \text{ m/s}$

We know, Speed of sound = $\sqrt{\frac{\gamma P}{f_0}} \Rightarrow (360)^2 = \frac{\gamma \times 1.5 \times 10^5}{1.7} \Rightarrow \gamma = \frac{(360)^2 \times 1.7}{1.5 \times 10^5} = 1.4688$

But $C_V = \frac{R}{\gamma - 1} = \frac{8.3}{1.488 - 1} = 17.72 \text{ J/mol-k}$

Again $\frac{C_P}{C_V} = \gamma$ So, $C_P = \gamma C_V = 17.72 \times 1.468 = 26.01 \approx 26 \text{ J/mol-k}$

35. $f = 5 \times 10^3 \text{ Hz}$, $T = 300 \text{ Hz}$, $\frac{\lambda}{2} = 3.3 \text{ cm} \Rightarrow \lambda = 6.6 \times 10^{-2} \text{ m}$

$V = f\lambda = 5 \times 10^3 \times 6.6 \times 10^{-2} = (66 \times 5) \text{ m/s}$

$V = \frac{\lambda P}{f}$ [$Pv = nRT \Rightarrow P = \frac{m}{mV} \times Rt \Rightarrow PM = f_0 RT \Rightarrow \frac{P}{f_0} = \frac{RT}{m}$]

$$= \sqrt{\frac{\gamma RT}{m}} (66 \times 5) = \sqrt{\frac{\gamma \times 8.3 \times 300}{32 \times 10^{-3}}} \Rightarrow (66 \times 5)^2 = \frac{\gamma \times 8.3 \times 300}{32 \times 10^{-3}} \Rightarrow \gamma = \frac{(66 \times 5)^2 \times 32 \times 10^{-3}}{8.3 \times 300} = 1.3995$$

$C_V = \frac{R}{\gamma - 1} = \frac{8.3}{0.3995} = 20.7 \text{ J/mol-k}$,

$C_P = C_V + R = 20.77 + 8.3 = 29.07 \text{ J/mol-k}$.

◆ ◆ ◆ ◆

CHAPTER 28 HEAT TRANSFER

1. $t_1 = 90^\circ\text{C}$, $t_2 = 10^\circ\text{C}$
 $l = 1 \text{ cm} = 1 \times 10^{-3} \text{ m}$
 $A = 10 \text{ cm} \times 10 \text{ cm} = 0.1 \times 0.1 \text{ m}^2 = 1 \times 10^{-2} \text{ m}^2$
 $K = 0.80 \text{ w/m-}^\circ\text{C}$

$$\frac{Q}{t} = \frac{KA(\theta_1 - \theta_2)}{l} = \frac{8 \times 10^{-1} \times 1 \times 10^{-2} \times 80}{1 \times 10^{-2}} = 64 \text{ J/s} = 64 \times 60 \text{ 3840 J.}$$

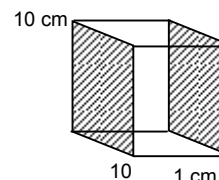

2. $t = 1 \text{ cm} = 0.01 \text{ m}$, $A = 0.8 \text{ m}^2$
 $\theta_1 = 300$, $\theta_2 = 80$
 $K = 0.025$,

$$\frac{Q}{t} = \frac{KA(\theta_1 - \theta_2)}{l} = \frac{0.025 \times 0.8 \times (300 - 80)}{0.01} = 440 \text{ watt.}$$

3. $K = 0.04 \text{ J/m-}^\circ\text{C}$, $A = 1.6 \text{ m}^2$
 $t_1 = 97^\circ\text{F} = 36.1^\circ\text{C}$ $t_2 = 47^\circ\text{F} = 8.33^\circ\text{C}$
 $l = 0.5 \text{ cm} = 0.005 \text{ m}$

$$\frac{Q}{t} = \frac{KA(\theta_1 - \theta_2)}{l} = \frac{4 \times 10^{-2} \times 1.6 \times 27.78}{5 \times 10^{-3}} = 356 \text{ J/s}$$

4. $A = 25 \text{ cm}^2 = 25 \times 10^{-4} \text{ m}^2$
 $l = 1 \text{ mm} = 10^{-3} \text{ m}$
 $K = 50 \text{ w/m-}^\circ\text{C}$

$\frac{Q}{t}$ = Rate of conversion of water into steam

$$= \frac{100 \times 10^{-3} \times 2.26 \times 10^6}{1 \text{ min}} = \frac{10^{-1} \times 2.26 \times 10^6}{60} = 0.376 \times 10^4$$

$$\frac{Q}{t} = \frac{KA(\theta_1 - \theta_2)}{l} \Rightarrow 0.376 \times 10^4 = \frac{50 \times 25 \times 10^{-4} \times (\theta - 100)}{10^{-3}}$$

$$\Rightarrow \theta = \frac{10^{-3} \times 0.376 \times 10^4}{50 \times 25 \times 10^{-4}} = \frac{10^5 \times 0.376}{50 \times 25} = 30.1 \approx 30$$

5. $K = 46 \text{ w/m-s}^\circ\text{C}$
 $l = 1 \text{ m}$
 $A = 0.04 \text{ cm}^2 = 4 \times 10^{-6} \text{ m}^2$
 $L_{\text{fusion ice}} = 3.36 \times 10^5 \text{ J/Kg}$

$$\frac{Q}{t} = \frac{46 \times 4 \times 10^{-6} \times 100}{1} = 5.4 \times 10^{-8} \text{ kg} \approx 5.4 \times 10^{-5} \text{ g.}$$

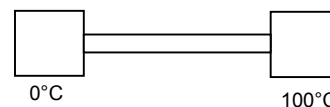

6. $A = 2400 \text{ cm}^2 = 2400 \times 10^{-4} \text{ m}^2$
 $l = 2 \text{ mm} = 2 \times 10^{-3} \text{ m}$
 $K = 0.06 \text{ w/m-}^\circ\text{C}$
 $\theta_1 = 20^\circ\text{C}$
 $\theta_2 = 0^\circ\text{C}$

$$\frac{Q}{t} = \frac{KA(\theta_1 - \theta_2)}{l} = \frac{0.06 \times 2400 \times 10^{-4} \times 20}{2 \times 10^{-3}} = 24 \times 6 \times 10^{-1} \times 10 = 24 \times 6 = 144 \text{ J/sec}$$

Rate in which ice melts = $\frac{m}{t} = \frac{Q}{t \times L} = \frac{144}{3.4 \times 10^5} \text{ Kg/h} = \frac{144 \times 3600}{3.4 \times 10^5} \text{ Kg/s} = 1.52 \text{ kg/s.}$

7. $l = 1 \text{ mm} = 10^{-3} \text{ m}$ $m = 10 \text{ kg}$
 $A = 200 \text{ cm}^2 = 2 \times 10^{-2} \text{ m}^2$
 $L_{\text{vap}} = 2.27 \times 10^6 \text{ J/kg}$
 $K = 0.80 \text{ J/m-s-}^\circ\text{C}$

$$dQ = 2.27 \times 10^6 \times 10,$$

$$\frac{dQ}{dt} = \frac{2.27 \times 10^7}{10^5} = 2.27 \times 10^2 \text{ J/s}$$

Again we know

$$\frac{dQ}{dt} = \frac{0.80 \times 2 \times 10^{-2} \times (42 - T)}{1 \times 10^{-3}}$$

$$\text{So, } \frac{8 \times 2 \times 10^{-3} (42 - T)}{10^{-3}} = 2.27 \times 10^2$$

$$\Rightarrow 16 \times 42 - 16T = 227 \Rightarrow T = 27.8 \approx 28^\circ\text{C}$$

8. $K = 45 \text{ w/m}^\circ\text{C}$

$$\ell = 60 \text{ cm} = 60 \times 10^{-2} \text{ m}$$

$$A = 0.2 \text{ cm}^2 = 0.2 \times 10^{-4} \text{ m}^2$$

Rate of heat flow,

$$= \frac{KA(\theta_1 - \theta_2)}{\ell} = \frac{45 \times 0.2 \times 10^{-4} \times 20}{60 \times 10^{-2}} = 30 \times 10^{-3} = 0.03 \text{ w}$$

9. $A = 10 \text{ cm}^2$, $h = 10 \text{ cm}$

$$\frac{\Delta Q}{\Delta t} = \frac{KA(\theta_1 - \theta_2)}{\ell} = \frac{200 \times 10^{-3} \times 30}{1 \times 10^{-3}} = 6000$$

Since heat goes out from both surfaces. Hence net heat coming out.

$$= \frac{\Delta Q}{\Delta t} = 6000 \times 2 = 12000, \quad \frac{\Delta Q}{\Delta t} = MS \frac{\Delta \theta}{\Delta t}$$

$$\Rightarrow 6000 \times 2 = 10^{-3} \times 10^{-1} \times 1000 \times 4200 \times \frac{\Delta \theta}{\Delta t}$$

$$\Rightarrow \frac{\Delta \theta}{\Delta t} = \frac{72000}{420} = 28.57$$

So, in 1 Sec. 28.57°C is dropped

$$\text{Hence for drop of } 1^\circ\text{C } \frac{1}{28.57} \text{ sec.} = 0.035 \text{ sec. is required}$$

10. $\ell = 20 \text{ cm} = 20 \times 10^{-2} \text{ m}$

$$A = 0.2 \text{ cm}^2 = 0.2 \times 10^{-4} \text{ m}^2$$

$$\theta_1 = 80^\circ\text{C}, \quad \theta_2 = 20^\circ\text{C}, \quad K = 385$$

$$(a) \frac{Q}{t} = \frac{KA(\theta_1 - \theta_2)}{\ell} = \frac{385 \times 0.2 \times 10^{-4} (80 - 20)}{20 \times 10^{-2}} = 385 \times 6 \times 10^{-4} \times 10 = 2310 \times 10^{-3} = 2.31$$

(b) Let the temp of the 11 cm point be θ

$$\frac{\Delta \theta}{\Delta l} = \frac{Q}{tKA}$$

$$\Rightarrow \frac{\Delta \theta}{\Delta l} = \frac{2.31}{385 \times 0.2 \times 10^{-4}}$$

$$\Rightarrow \frac{\theta - 20}{11 \times 10^{-2}} = \frac{2.31}{385 \times 0.2 \times 10^{-4}}$$

$$\Rightarrow \theta - 20 = \frac{2.31 \times 10^4}{385 \times 0.2} \times 11 \times 10^{-2} = 33$$

$$\Rightarrow \theta = 33 + 20 = 53$$

11. Let the point to be touched be 'B'

No heat will flow when, the temp at that point is also 25°C

i.e. $Q_{AB} = Q_{BC}$

$$\text{So, } \frac{KA(100 - 25)}{100 - x} = \frac{KA(25 - 0)}{x}$$

$$\Rightarrow 75x = 2500 - 25x \Rightarrow 100x = 2500 \Rightarrow x = 25 \text{ cm from the end with } 0^\circ\text{C}$$

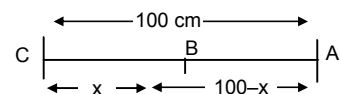
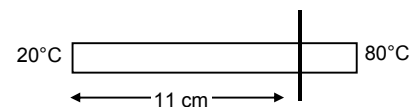
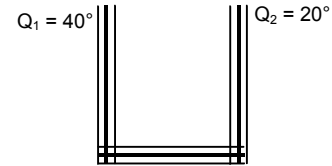

12. $V = 216 \text{ cm}^3$
 $a = 6 \text{ cm}$, Surface area = $6 a^2 = 6 \times 36 \text{ m}^2$
 $t = 0.1 \text{ cm}$ $\frac{Q}{t} = 100 \text{ W}$,

$$\frac{Q}{t} = \frac{KA(\theta_1 - \theta_2)}{\ell}$$

$$\Rightarrow 100 = \frac{K \times 6 \times 36 \times 10^{-4} \times 5}{0.1 \times 10^{-2}}$$

$$\Rightarrow K = \frac{100}{6 \times 36 \times 5 \times 10^{-1}} = 0.9259 \text{ W/m}^\circ\text{C} \approx 0.92 \text{ W/m}^\circ\text{C}$$

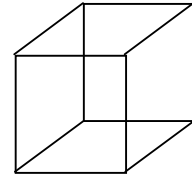

13. Given $\theta_1 = 1^\circ\text{C}$, $\theta_2 = 0^\circ\text{C}$
 $K = 0.50 \text{ w/m}^\circ\text{C}$, $d = 2 \text{ mm} = 2 \times 10^{-3} \text{ m}$
 $A = 5 \times 10^{-2} \text{ m}^2$, $v = 10 \text{ cm/s} = 0.1 \text{ m/s}$
Power = Force \times Velocity = $Mg \times v$

Again Power = $\frac{dQ}{dt} = \frac{KA(\theta_1 - \theta_2)}{d}$

So, $Mgv = \frac{KA(\theta_1 - \theta_2)}{d}$

$$\Rightarrow M = \frac{KA(\theta_1 - \theta_2)}{dvg} = \frac{5 \times 10^{-1} \times 5 \times 10^{-2} \times 1}{2 \times 10^{-3} \times 10^{-1} \times 10} = 12.5 \text{ kg.}$$

14. $K = 1.7 \text{ W/m}^\circ\text{C}$ $f_w = 1000 \text{ Kg/m}^3$
 $L_{\text{ice}} = 3.36 \times 10^5 \text{ J/kg}$ $T = 10 \text{ cm} = 10 \times 10^{-2} \text{ m}$

(a) $\frac{Q}{t} = \frac{KA(\theta_1 - \theta_2)}{\ell} \Rightarrow \frac{\ell}{t} = \frac{KA(\theta_1 - \theta_2)}{Q} = \frac{KA(\theta_1 - \theta_2)}{mL}$

$$= \frac{KA(\theta_1 - \theta_2)}{A t f_w L} = \frac{1.7 \times [0 - (-10)]}{10 \times 10^{-2} \times 1000 \times 3.36 \times 10^5}$$

$$= \frac{17}{3.36} \times 10^{-7} = 5.059 \times 10^{-7} \approx 5 \times 10^{-7} \text{ m/sec}$$

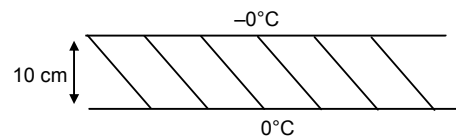

(b) let us assume that x length of ice has become formed to form a small strip of ice of length dx, dt time is required.

$$\frac{dQ}{dt} = \frac{KA(\Delta\theta)}{x} \Rightarrow \frac{dmL}{dt} = \frac{KA(\Delta\theta)}{x} \Rightarrow \frac{A dx f_w L}{dt} = \frac{KA(\Delta\theta)}{x}$$

$$\Rightarrow \frac{dx f_w L}{dt} = \frac{K(\Delta\theta)}{x} \Rightarrow dt = \frac{x dx f_w L}{K(\Delta\theta)}$$

$$\Rightarrow \int_0^t dt = \frac{f_w L}{K(\Delta\theta)} \int_0^t x dx \Rightarrow t = \frac{f_w L}{K(\Delta\theta)} \left[\frac{x^2}{2} \right]_0^t = \frac{f_w L}{K \Delta\theta} \frac{L^2}{2}$$

Putting values

$$\Rightarrow t = \frac{1000 \times 3.36 \times 10^5 \times (10 \times 10^{-2})^2}{1.7 \times 10 \times 2} = \frac{3.36}{2 \times 17} \times 10^6 \text{ sec.} = \frac{3.36 \times 10^6}{2 \times 17 \times 3600} \text{ hrs} = 27.45 \text{ hrs} \approx 27.5 \text{ hrs.}$$

15. let 'B' be the maximum level upto which ice is formed. Hence the heat conducted at that point from both the levels is the same.

Let $AB = x$

i.e. $\frac{Q}{t}_{\text{ice}} = \frac{Q}{t}_{\text{water}} \Rightarrow \frac{K_{\text{ice}} \times A \times 10}{x} = \frac{K_{\text{water}} \times A \times 4}{(1-x)}$

$$\Rightarrow \frac{1.7 \times 10}{x} = \frac{5 \times 10^{-1} \times 4}{1-x} \Rightarrow \frac{17}{x} = \frac{2}{1-x}$$

$$\Rightarrow 17 - 17x = 2x \Rightarrow 19x = 17 \Rightarrow x = \frac{17}{19} = 0.894 \approx 89 \text{ cm}$$

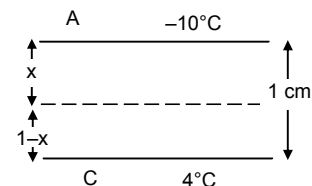

16. $K_{AB} = 50 \text{ J/m-s-}^\circ\text{C}$ $\theta_A = 40^\circ\text{C}$
 $K_{BC} = 200 \text{ J/m-s-}^\circ\text{C}$ $\theta_B = 80^\circ\text{C}$
 $K_{AC} = 400 \text{ J/m-s-}^\circ\text{C}$ $\theta_C = 80^\circ\text{C}$
Length = 20 cm = $20 \times 10^{-2} \text{ m}$
 $A = 1 \text{ cm}^2 = 1 \times 10^{-4} \text{ m}^2$

$$(a) \frac{Q_{AB}}{t} = \frac{K_{AB} \times A(\theta_B - \theta_A)}{l} = \frac{50 \times 1 \times 10^{-4} \times 40}{20 \times 10^{-2}} = 1 \text{ W.}$$

$$(b) \frac{Q_{AC}}{t} = \frac{K_{AC} \times A(\theta_C - \theta_A)}{l} = \frac{400 \times 1 \times 10^{-4} \times 40}{20 \times 10^{-2}} = 800 \times 10^{-2} = 8$$

$$(c) \frac{Q_{BC}}{t} = \frac{K_{BC} \times A(\theta_B - \theta_C)}{l} = \frac{200 \times 1 \times 10^{-4} \times 0}{20 \times 10^{-2}} = 0$$

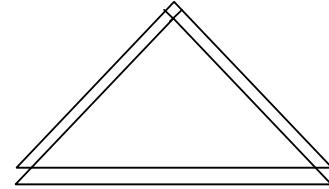

17. We know $Q = \frac{KA(\theta_1 - \theta_2)}{d}$

$$Q_1 = \frac{KA(\theta_1 - \theta_2)}{d_1},$$

$$Q_2 = \frac{KA(\theta_1 - \theta_2)}{d_2}$$

$$\frac{Q_1}{Q_2} = \frac{\frac{KA(\theta_1 - \theta_2)}{\pi r}}{\frac{KA(\theta_1 - \theta_2)}{2r}} = \frac{2r}{\pi r} = \frac{2}{\pi}$$

$$[d_1 = \pi r, \quad d_2 = 2r]$$

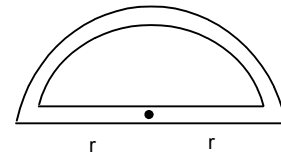

18. The rate of heat flow per sec.

$$= \frac{dQ_A}{dt} = KA \frac{d\theta}{dt}$$

The rate of heat flow per sec.

$$= \frac{dQ_B}{dt} = KA \frac{d\theta_B}{dt}$$

This part of heat is absorbed by the red.

$$\frac{Q}{t} = \frac{ms\Delta\theta}{dt} \quad \text{where } \frac{d\theta}{dt} = \text{Rate of net temp. variation}$$

$$\Rightarrow \frac{msd\theta}{dt} = KA \frac{d\theta_A}{dt} - KA \frac{d\theta_B}{dt} \quad \Rightarrow ms \frac{d\theta}{dt} = KA \left(\frac{d\theta_A}{dt} - \frac{d\theta_B}{dt} \right)$$

$$\Rightarrow 0.4 \times \frac{d\theta}{dt} = 200 \times 1 \times 10^{-4} (5 - 2.5) \text{ }^\circ\text{C/cm}$$

$$\Rightarrow 0.4 \times \frac{d\theta}{dt} = 200 \times 10^{-4} \times 2.5$$

$$\Rightarrow \frac{d\theta}{dt} = \frac{200 \times 2.5 \times 10^{-4}}{0.4 \times 10^{-2}} \text{ }^\circ\text{C/m} = 1250 \times 10^{-2} = 12.5 \text{ }^\circ\text{C/m}$$

19. Given

$$K_{\text{rubber}} = 0.15 \text{ J/m-s-}^\circ\text{C} \quad T_2 - T_1 = 90^\circ\text{C}$$

We know for radial conduction in a Cylinder

$$\frac{Q}{t} = \frac{2\pi Kl(T_2 - T_1)}{\ln(R_2/R_1)}$$

$$= \frac{2 \times 3.14 \times 15 \times 10^{-2} \times 50 \times 10^{-1} \times 90}{\ln(1.2/1)} = 232.5 \approx 233 \text{ J/s.}$$

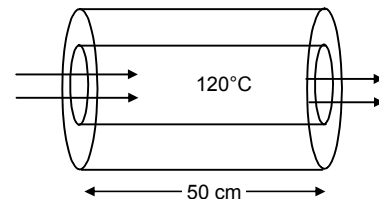

20. $\frac{dQ}{dt}$ = Rate of flow of heat

Let us consider a strip at a distance r from the center of thickness dr .

$$\frac{dQ}{dt} = \frac{K \times 2\pi r d \times d\theta}{dr} \quad [d\theta = \text{Temperature diff across the thickness } dr]$$

$$\Rightarrow C = \frac{K \times 2\pi r d \times d\theta}{dr} \quad \left[c = \frac{d\theta}{dr} \right]$$

$$\Rightarrow C \frac{dr}{r} = K2\pi d d\theta$$

Integrating

$$\Rightarrow C \int_{r_1}^{r_2} \frac{dr}{r} = K2\pi d \int_{\theta_1}^{\theta_2} d\theta \quad \Rightarrow C [\log r]_{r_1}^{r_2} = K2\pi d (\theta_2 - \theta_1)$$

$$\Rightarrow C(\log r_2 - \log r_1) = K2\pi d (\theta_2 - \theta_1) \Rightarrow C \log \left(\frac{r_2}{r_1} \right) = K2\pi d (\theta_2 - \theta_1)$$

$$\Rightarrow C = \frac{K2\pi d(\theta_2 - \theta_1)}{\log(r_2/r_1)}$$

21. $T_1 > T_2$

$$A = \pi(R_2^2 - R_1^2)$$

$$\text{So, } Q = \frac{KA(T_2 - T_1)}{l} = \frac{KA(R_2^2 - R_1^2)(T_2 - T_1)}{l}$$

Considering a concentric cylindrical shell of radius 'r' and thickness 'dr'. The radial heat flow through the shell

$$H = \frac{dQ}{dt} = -KA \frac{d\theta}{dt} \quad [(-)\text{ve because as } r \text{ increases } \theta \text{ decreases}]$$

$$A = 2\pi r l \quad H = -2\pi r l K \frac{d\theta}{dt}$$

$$\text{or } \int_{R_1}^{R_2} \frac{dr}{r} = -\frac{2\pi l K}{H} \int_{T_1}^{T_2} d\theta$$

Integrating and simplifying we get

$$H = \frac{dQ}{dt} = \frac{2\pi K L (T_2 - T_1)}{\text{Loge}(R_2/R_1)} = \frac{2\pi K L (T_2 - T_1)}{\ln(R_2/R_1)}$$

22. Here the thermal conductivities are in series,

$$\therefore \frac{\frac{K_1 A (\theta_1 - \theta_2)}{l_1} \times \frac{K_2 A (\theta_1 - \theta_2)}{l_2}}{\frac{K_1 A (\theta_1 - \theta_2)}{l_1} + \frac{K_2 A (\theta_1 - \theta_2)}{l_2}} = \frac{KA(\theta_1 - \theta_2)}{l_1 + l_2}$$

$$\Rightarrow \frac{\frac{K_1 \times K_2}{l_1 \times l_2}}{\frac{K_1}{l_1} + \frac{K_2}{l_2}} = \frac{K}{l_1 + l_2}$$

$$\Rightarrow \frac{K_1 K_2}{K_1 l_2 + K_2 l_1} = \frac{K}{l_1 + l_2} \Rightarrow K = \frac{(K_1 K_2)(l_1 + l_2)}{K_1 l_2 + K_2 l_1}$$

23. $K_{Cu} = 390 \text{ w/m}^\circ\text{C}$ $K_{St} = 46 \text{ w/m}^\circ\text{C}$

Now, Since they are in series connection,

So, the heat passed through the crosssections in the same.

So, $Q_1 = Q_2$

$$\text{Or } \frac{K_{Cu} \times A \times (\theta - 0)}{l} = \frac{K_{St} \times A \times (100 - \theta)}{l}$$

$$\Rightarrow 390(\theta - 0) = 46 \times 100 - 46 \theta \Rightarrow 436 \theta = 4600$$

$$\Rightarrow \theta = \frac{4600}{436} = 10.55 \approx 10.6^\circ\text{C}$$

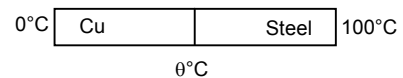
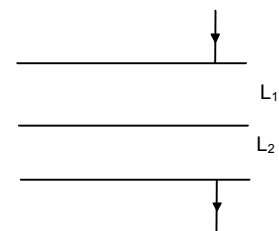
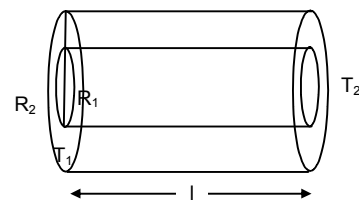
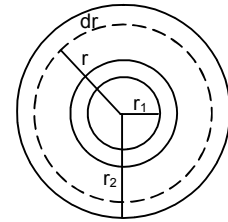

24. As the Aluminum rod and Copper rod joined are in parallel

$$\frac{Q}{t} = \left(\frac{Q}{t}\right)_{Al} + \left(\frac{Q}{t}\right)_{Cu}$$

$$\Rightarrow \frac{KA(\theta_1 - \theta_2)}{l} = \frac{K_1 A(\theta_1 - \theta_2)}{l} + \frac{K_2 A(\theta_1 - \theta_2)}{l}$$

$$\Rightarrow K = K_1 + K_2 = (390 + 200) = 590$$

$$\frac{Q}{t} = \frac{KA(\theta_1 - \theta_2)}{l} = \frac{590 \times 1 \times 10^{-4} \times (60 - 20)}{1} = 590 \times 10^{-4} \times 40 = 2.36 \text{ Watt}$$

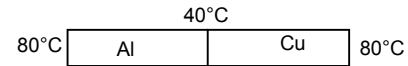

25. $K_{Al} = 200 \text{ w/m}^\circ\text{C}$ $K_{Cu} = 400 \text{ w/m}^\circ\text{C}$

$$A = 0.2 \text{ cm}^2 = 2 \times 10^{-5} \text{ m}^2$$

$$l = 20 \text{ cm} = 2 \times 10^{-1} \text{ m}$$

Heat drawn per second

$$= Q_{Al} + Q_{Cu} = \frac{K_{Al} \times A(80 - 40)}{l} + \frac{K_{Cu} \times A(80 - 40)}{l} = \frac{2 \times 10^{-5} \times 40}{2 \times 10^{-1}} [200 + 400] = 2.4 \text{ J}$$

$$\text{Heat drawn per min} = 2.4 \times 60 = 144 \text{ J}$$

26. $(Q/t)_{AB} = (Q/t)_{BE \text{ bent}} + (Q/t)_{BE}$

$$(Q/t)_{BE \text{ bent}} = \frac{KA(\theta_1 - \theta_2)}{70} \quad (Q/t)_{BE} = \frac{KA(\theta_1 - \theta_2)}{60}$$

$$\frac{(Q/t)_{BE \text{ bent}}}{(Q/t)_{BE}} = \frac{60}{70} = \frac{6}{7}$$

$$(Q/t)_{BE \text{ bent}} + (Q/t)_{BE} = 130$$

$$\Rightarrow (Q/t)_{BE \text{ bent}} + (Q/t)_{BE} \frac{7}{6} = 130$$

$$\Rightarrow \left(\frac{7}{6} + 1\right)(Q/t)_{BE \text{ bent}} = 130 \quad \Rightarrow (Q/t)_{BE \text{ bent}} = \frac{130 \times 6}{13} = 60$$

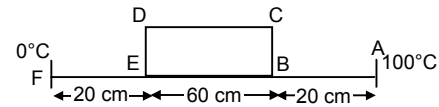

27. $\frac{Q}{t} \text{ bent} = \frac{780 \times A \times 100}{70}$

$$\frac{Q}{t} \text{ str} = \frac{390 \times A \times 100}{60}$$

$$\frac{(Q/t) \text{ bent}}{(Q/t) \text{ str}} = \frac{780 \times A \times 100}{70} \times \frac{60}{390 \times A \times 100} = \frac{12}{7}$$

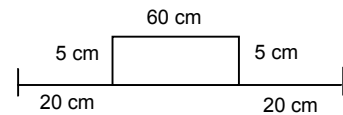

28. (a) $\frac{Q}{t} = \frac{KA(\theta_1 - \theta_2)}{l} = \frac{1 \times 2 \times 1(40 - 32)}{2 \times 10^{-3}} = 8000 \text{ J/sec.}$

$$(b) \text{ Resistance of glass} = \frac{l}{ak_g} + \frac{l}{ak_g}$$

$$\text{Resistance of air} = \frac{l}{ak_a}$$

$$\text{Net resistance} = \frac{l}{ak_g} + \frac{l}{ak_g} + \frac{l}{ak_a}$$

$$= \frac{l}{a} \left(\frac{2}{k_g} + \frac{1}{k_a} \right) = \frac{l}{a} \left(\frac{2k_a + k_g}{K_g k_a} \right)$$

$$= \frac{1 \times 10^{-3}}{2} \left(\frac{2 \times 0.025 + 1}{0.025} \right)$$

$$= \frac{1 \times 10^{-3} \times 1.05}{0.05}$$

$$\frac{Q}{t} = \frac{\theta_1 - \theta_2}{R} = \frac{8 \times 0.05}{1 \times 10^{-3} \times 1.05} = 380.9 \approx 381 \text{ W}$$

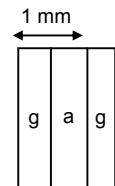

29. Now; Q/t remains same in both cases

$$\text{In Case I: } \frac{K_A \times A \times (100 - 70)}{\ell} = \frac{K_B \times A \times (70 - 0)}{\ell}$$

$$\Rightarrow 30 K_A = 70 K_B$$

$$\text{In Case II: } \frac{K_B \times A \times (100 - \theta)}{\ell} = \frac{K_A \times A \times (\theta - 0)}{\ell}$$

$$\Rightarrow 100K_B - K_B \theta = K_A \theta$$

$$\Rightarrow 100K_B - K_B \theta = \frac{70}{30} K_B \theta$$

$$\Rightarrow 100 = \frac{7}{3} \theta + \theta \quad \Rightarrow \theta = \frac{300}{10} = 30^\circ\text{C}$$

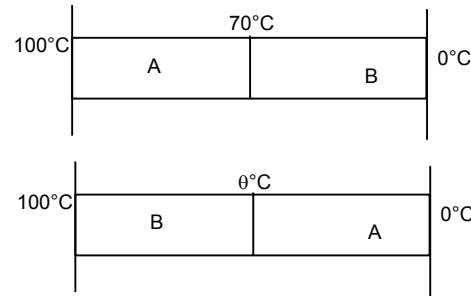

30. $\theta_1 - \theta_2 = 100$

$$\frac{Q}{t} = \frac{\theta_1 - \theta_2}{R}$$

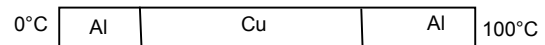

$$R = R_1 + R_2 + R_3 = \frac{\ell}{aK_{Al}} + \frac{\ell}{aK_{Cu}} + \frac{\ell}{aK_{Al}} = \frac{\ell}{a} \left(\frac{2}{200} + \frac{1}{400} \right) = \frac{\ell}{a} \left(\frac{4+1}{400} \right) = \frac{\ell}{a} \frac{1}{80}$$

$$\frac{Q}{t} = \frac{100}{(\ell/a)(1/80)} \Rightarrow 40 = 80 \times 100 \times \frac{a}{\ell}$$

$$\Rightarrow \frac{a}{\ell} = \frac{1}{200}$$

For (b)

$$R = R_1 + R_2 = R_1 + \frac{R_{Cu}R_{Al}}{R_{Cu} + R_{Al}} = R_{Al} + \frac{R_{Cu}R_{Al}}{R_{Cu} + R_{Al}} = \frac{\frac{\ell}{AK_{Al}} + \frac{\ell}{AK_{Cu}} + \frac{\ell}{AK_{Al}}}{\frac{\ell}{A_{Cu}} + \frac{\ell}{A_{Al}}}$$

$$= \frac{\frac{\ell}{AK_{Al}} + \frac{\ell}{A} + \frac{\ell}{K_{Al} + K_{Cu}}}{\frac{\ell}{A} \left(\frac{1}{200} + \frac{1}{200 + 400} \right)} = \frac{\ell}{A} \times \frac{4}{600}$$

$$\frac{Q}{t} = \frac{\theta_1 - \theta_2}{R} = \frac{100}{(\ell/A)(4/600)} = \frac{100 \times 600 A}{4 \ell} = \frac{100 \times 600}{4} \times \frac{1}{200} = 75$$

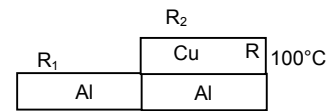

For (c)

$$\frac{1}{R} = \frac{1}{R_1} + \frac{1}{R_2} + \frac{1}{R_3} = \frac{1}{\frac{\ell}{aK_{Al}}} + \frac{1}{\frac{\ell}{aK_{Cu}}} + \frac{1}{\frac{\ell}{aK_{Al}}}$$

$$= \frac{a}{\ell} (K_{Al} + K_{Cu} + K_{Al}) = \frac{a}{\ell} (2 \times 200 + 400) = \frac{a}{\ell} (800)$$

$$\Rightarrow R = \frac{\ell}{a} \times \frac{1}{800}$$

$$\Rightarrow \frac{Q}{t} = \frac{\theta_1 - \theta_2}{R} = \frac{100 \times 800 \times a}{\ell}$$

$$= \frac{100 \times 800}{200} = 400 \text{ W}$$

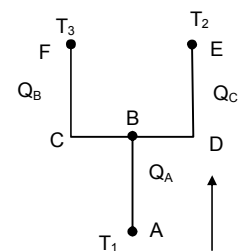
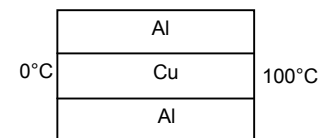

31. Let the temp. at B be T

$$\frac{Q_A}{t} = \frac{Q_B}{t} + \frac{Q_C}{t}$$

$$\Rightarrow \frac{KA(T_1 - T)}{\ell} = \frac{KA(T - T_3)}{\ell + (\ell/2)} + \frac{KA(T - T_2)}{\ell + (\ell/2)}$$

$$\Rightarrow \frac{T_1 - T}{\ell} = \frac{T - T_3}{3\ell/2} + \frac{T - T_2}{3\ell/2}$$

$$\Rightarrow 3T_1 - 3T = 4T - 2(T_2 + T_3)$$

$$\Rightarrow -7T = -3T_1 - 2(T_2 + T_3)$$

$$\Rightarrow T = \frac{3T_1 + 2(T_2 + T_3)}{7}$$

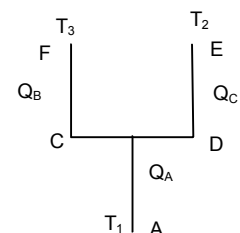

32. The temp at the both ends of bar F is same

Rate of Heat flow to right = Rate of heat flow through left

$$\Rightarrow (Q/t)_A + (Q/t)_C = (Q/t)_B + (Q/t)_D$$

$$\Rightarrow \frac{K_A(T_1 - T)A}{l} + \frac{K_C(T_1 - T)A}{l} = \frac{K_B(T - T_2)A}{l} + \frac{K_D(T - T_2)A}{l}$$

$$\Rightarrow 2K_0(T_1 - T) = 2 \times 2K_0(T - T_2)$$

$$\Rightarrow T_1 - T = 2T - 2T_2$$

$$\Rightarrow T = \frac{T_1 + 2T_2}{3}$$

- 33.
- $\tan \phi = \frac{r_2 - r_1}{L} = \frac{(y - r_1)}{x}$

$$\Rightarrow xr_2 - xr_1 = yL - r_1L$$

Differentiating wr to 'x'

$$\Rightarrow r_2 - r_1 = \frac{Ldy}{dx} - 0$$

$$\Rightarrow \frac{dy}{dx} = \frac{r_2 - r_1}{L} \Rightarrow dx = \frac{dyL}{(r_2 - r_1)} \quad \dots(1)$$

$$\text{Now } \frac{Q}{T} = \frac{K\pi y^2 d\theta}{dx} \Rightarrow \frac{\theta dx}{T} = K\pi y^2 d\theta$$

$$\Rightarrow \frac{\theta L dy}{r_2 r_1} = K\pi y^2 d\theta \quad \text{from(1)}$$

$$\Rightarrow d\theta = \frac{QLdy}{(r_2 - r_1)K\pi y^2}$$

Integrating both side

$$\Rightarrow \int_{\theta_1}^{\theta_2} d\theta = \frac{QL}{(r_2 - r_1)K\pi} \int_{r_1}^{r_2} \frac{dy}{y}$$

$$\Rightarrow (\theta_2 - \theta_1) = \frac{QL}{(r_2 - r_1)K\pi} \times \left[\frac{-1}{y} \right]_{r_1}^{r_2}$$

$$\Rightarrow (\theta_2 - \theta_1) = \frac{QL}{(r_2 - r_1)K\pi} \times \left[\frac{1}{r_1} - \frac{1}{r_2} \right]$$

$$\Rightarrow (\theta_2 - \theta_1) = \frac{QL}{(r_2 - r_1)K\pi} \times \left[\frac{r_2 - r_1}{r_1 + r_2} \right]$$

$$\Rightarrow Q = \frac{K\pi r_1 r_2 (\theta_2 - \theta_1)}{L}$$

- 34.
- $\frac{d\theta}{dt} = \frac{60}{10 \times 60} = 0.1^\circ\text{C/sec}$

$$\frac{dQ}{dt} = \frac{KA}{d} (\theta_1 - \theta_2)$$

$$= \frac{KA \times 0.1}{d} + \frac{KA \times 0.2}{d} + \dots + \frac{KA \times 60}{d}$$

$$= \frac{KA}{d} (0.1 + 0.2 + \dots + 60) = \frac{KA}{d} \times \frac{600}{2} \times (2 \times 0.1 + 599 \times 0.1)$$

$$[\therefore a + 2a + \dots + na = n/2\{2a + (n-1)a\}]$$

$$= \frac{200 \times 1 \times 10^{-4}}{20 \times 10^{-2}} \times 300 \times (0.2 + 59.9) = \frac{200 \times 10^{-2} \times 300 \times 60.1}{20}$$

$$= 3 \times 10 \times 60.1 = 1803 \text{ w} \approx 1800 \text{ w}$$

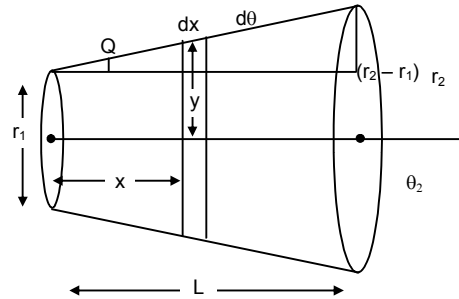

35. $a = r_1 = 5 \text{ cm} = 0.05 \text{ m}$

$b = r_2 = 20 \text{ cm} = 0.2 \text{ m}$

$\theta_1 = T_1 = 50^\circ\text{C}$

$\theta_2 = T_2 = 10^\circ\text{C}$

Now, considering a small strip of thickness 'dr' at a distance 'r'.

$A = 4 \pi r^2$

$H = -4 \pi r^2 K \frac{d\theta}{dr}$ [(-)ve because with increase of r, θ decreases]

$= \int_a^b \frac{dr}{r^2} = \frac{-4\pi K}{H} \int_{\theta_1}^{\theta_2} d\theta$ On integration,

$H = \frac{dQ}{dt} = K \frac{4\pi ab(\theta_1 - \theta_2)}{(b-a)}$

Putting the values we get

$\frac{K \times 4 \times 3.14 \times 5 \times 20 \times 40 \times 10^{-3}}{15 \times 10^{-2}} = 100$

$\Rightarrow K = \frac{15}{4 \times 3.14 \times 4 \times 10^{-1}} = 2.985 \approx 3 \text{ w/m}^\circ\text{C}$

36. $\frac{Q}{t} = \frac{KA(T_1 - T_2)}{L}$ Rise in Temp. in $T_2 \Rightarrow \frac{KA(T_1 - T_2)}{Lm_2s_2}$

Fall in Temp in $T_1 = \frac{KA(T_1 - T_2)}{Lm_1s_1}$ Final Temp. $T_1 \Rightarrow T_1 - \frac{KA(T_1 - T_2)}{Lm_1s_1}$

Final Temp. $T_2 = T_2 + \frac{KA(T_1 - T_2)}{Lm_2s_2}$

Final $\frac{\Delta T}{dt} = T_1 - \frac{KA(T_1 - T_2)}{Lm_1s_1} - T_2 - \frac{KA(T_1 - T_2)}{Lm_2s_2}$

$= (T_1 - T_2) - \frac{2KA(T_1 - T_2)}{Lms} = \frac{dT}{dt} = -\frac{2KA(T_1 - T_2)}{Lms} \Rightarrow \int_{(T_1 - T_2)}^{(T_1 - T_2)/2} \frac{dt}{(T_1 - T_2)} = \frac{-2KA}{Lms} dt$

$\Rightarrow \ln \frac{(T_1 - T_2)/2}{(T_1 - T_2)} = \frac{-2KAt}{Lms} \Rightarrow \ln (1/2) = \frac{-2KAt}{Lms} \Rightarrow \ln 2 = \frac{2KAt}{Lms} \Rightarrow t = \ln 2 \frac{Lms}{2KA}$

37. $\frac{Q}{t} = \frac{KA(T_1 - T_2)}{L}$ Rise in Temp. in $T_2 \Rightarrow \frac{KA(T_1 - T_2)}{Lm_2s_2}$

Fall in Temp in $T_1 \Rightarrow \frac{KA(T_1 - T_2)}{Lm_1s_1}$ Final Temp. $T_1 = T_1 - \frac{KA(T_1 - T_2)}{Lm_1s_1}$

Final Temp. $T_2 = T_2 + \frac{KA(T_1 - T_2)}{Lm_2s_2}$

$\frac{\Delta T}{dt} = T_1 - \frac{KA(T_1 - T_2)}{Lm_1s_1} - T_2 - \frac{KA(T_1 - T_2)}{Lm_2s_2} = (T_1 - T_2) - \left[\frac{KA(T_1 - T_2)}{Lm_1s_1} + \frac{KA(T_1 - T_2)}{Lm_2s_2} \right]$

$\Rightarrow \frac{dT}{dt} = -\frac{KA(T_1 - T_2)}{L} \left(\frac{1}{m_1s_1} + \frac{1}{m_2s_2} \right) \Rightarrow \frac{dT}{(T_1 - T_2)} = -\frac{KA}{L} \left(\frac{m_2s_2 + m_1s_1}{m_1s_1m_2s_2} \right) dt$

$\Rightarrow \ln \Delta t = -\frac{KA}{L} \left(\frac{m_2s_2 + m_1s_1}{m_1s_1m_2s_2} \right) t + C$

At time $t = 0$, $T = T_0$, $\Delta T = \Delta T_0 \Rightarrow C = \ln \Delta T_0$

$\Rightarrow \ln \frac{\Delta T}{\Delta T_0} = -\frac{KA}{L} \left(\frac{m_2s_2 + m_1s_1}{m_1s_1m_2s_2} \right) t \Rightarrow \frac{\Delta T}{\Delta T_0} = e^{-\frac{KA}{L} \left(\frac{m_1s_1 + m_2s_2}{m_1s_1m_2s_2} \right) t}$

$\Rightarrow \Delta T = \Delta T_0 e^{-\frac{KA}{L} \left(\frac{m_1s_1 + m_2s_2}{m_1s_1m_2s_2} \right) t} = (T_2 - T_1) e^{-\frac{KA}{L} \left(\frac{m_1s_1 + m_2s_2}{m_1s_1m_2s_2} \right) t}$

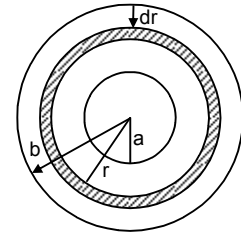
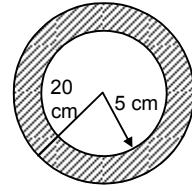

$$\begin{aligned}
 38. \quad \frac{Q}{t} &= \frac{KA(T_s - T_0)}{x} \Rightarrow \frac{nC_p dT}{dt} = \frac{KA(T_s - T_0)}{x} \\
 &\Rightarrow \frac{n(5/2)RdT}{dt} = \frac{KA(T_s - T_0)}{x} \Rightarrow \frac{dT}{dt} = \frac{-2LA}{5nRx}(T_s - T_0) \\
 &\Rightarrow \frac{dT}{(T_s - T_0)} = -\frac{2KA dt}{5nRx} \Rightarrow \ln(T_s - T_0)_{T_0}^T = -\frac{2KA dt}{5nRx} \\
 &\Rightarrow \ln \frac{T_s - T}{T_s - T_0} = -\frac{2KA dt}{5nRx} \Rightarrow T_s - T = (T_s - T_0)e^{-\frac{2KA dt}{5nRx}} \\
 &\Rightarrow T = T_s - (T_s - T_0)e^{-\frac{2KA dt}{5nRx}} = T_s + (T_0 - T_s)e^{-\frac{2KA dt}{5nRx}} \\
 &\Rightarrow \Delta T = T - T_0 = (T_s - T_0) + (T_0 - T_s)e^{-\frac{2KA dt}{5nRx}} = (T_s - T_0) \left(1 + e^{-\frac{2KA dt}{5nRx}} \right) \\
 &\Rightarrow \frac{P_a AL}{nR} = (T_s - T_0) \left(1 + e^{-\frac{2KA dt}{5nRx}} \right) \quad [p_a dv = nRdt \quad P_a A l = nRdt \quad dT = \frac{P_a AL}{nR}] \\
 &\Rightarrow L = \frac{nR}{P_a A} (T_s - T_0) \left(1 + e^{-\frac{2KA dt}{5nRx}} \right)
 \end{aligned}$$

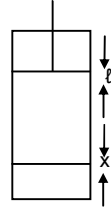

$$39. \quad A = 1.6 \text{ m}^2, \quad T = 37^\circ\text{C} = 310 \text{ K}, \quad \sigma = 6.0 \times 10^{-8} \text{ w/m}^2\text{-K}^4$$

Energy radiated per second

$$= A\sigma T^4 = 1.6 \times 6 \times 10^{-8} \times (310)^4 = 8865801 \times 10^{-4} = 886.58 \approx 887 \text{ J}$$

$$40. \quad A = 12 \text{ cm}^2 = 12 \times 10^{-4} \text{ m}^2 \quad T = 20^\circ\text{C} = 293 \text{ K}$$

$$e = 0.8$$

$$\sigma = 6 \times 10^{-8} \text{ w/m}^2\text{-k}^4$$

$$\frac{Q}{t} = Ae \sigma T^4 = 12 \times 10^{-4} \times 0.8 \times 6 \times 10^{-8} (293)^4 = 4.245 \times 10^{12} \times 10^{-13} = 0.4245 \approx 0.42$$

41. E → Energy radiated per unit area per unit time

Rate of heat flow → Energy radiated

(a) Per time = E × A

$$\text{So, } E_{A1} = \frac{e\sigma T^4 \times A}{e\sigma T^4 \times A} = \frac{4\pi r^2}{4\pi(2r)^2} = \frac{1}{4} \quad \therefore 1 : 4$$

(b) Emissivity of both are same

$$= \frac{m_1 S_1 dT_1}{m_2 S_2 dT_2} = 1$$

$$\Rightarrow \frac{dT_1}{dT_2} = \frac{m_2 S_2}{m_1 S_1} = \frac{s_1 4\pi r_1^3 \times S_2}{s_2 4\pi r_2^3 \times S_1} = \frac{1 \times \pi \times 900}{3.4 \times 8\pi \times 390} = 1 : 2 : 9$$

$$42. \quad \frac{Q}{t} = Ae \sigma T^4$$

$$\Rightarrow T^4 = \frac{\theta}{teA\sigma} \Rightarrow T^4 = \frac{100}{0.8 \times 2 \times 3.14 \times 4 \times 10^{-5} \times 1 \times 6 \times 10^{-8}}$$

$$\Rightarrow T = 1697.0 \approx 1700 \text{ K}$$

$$43. \quad (a) \quad A = 20 \text{ cm}^2 = 20 \times 10^{-4} \text{ m}^2, \quad T = 57^\circ\text{C} = 330 \text{ K}$$

$$E = A \sigma T^4 = 20 \times 10^{-4} \times 6 \times 10^{-8} \times (330)^4 \times 10^4 = 1.42 \text{ J}$$

$$(b) \quad \frac{E}{t} = A\sigma e(T_1^4 - T_2^4), \quad A = 20 \text{ cm}^2 = 20 \times 10^{-4} \text{ m}^2$$

$$\sigma = 6 \times 10^{-8} \quad T_1 = 473 \text{ K}, \quad T_2 = 330 \text{ K}$$

$$= 20 \times 10^{-4} \times 6 \times 10^{-8} \times 1[(473)^4 - (330)^4]$$

$$= 20 \times 6 \times [5.005 \times 10^{10} - 1.185 \times 10^{10}]$$

$$= 20 \times 6 \times 3.82 \times 10^{-2} = 4.58 \text{ w}$$

from the ball.

44. $r = 1 \text{ cm} = 1 \times 10^{-3} \text{ m}$
 $A = 4\pi(10^{-2})^2 = 4\pi \times 10^{-4} \text{ m}^2$
 $E = 0.3, \quad \sigma = 6 \times 10^{-8}$
 $\frac{E}{t} = A\sigma e(T_1^4 - T_2^4)$
 $= 0.3 \times 6 \times 10^{-8} \times 4\pi \times 10^{-4} \times [(100)^4 - (300)^4]$
 $= 0.3 \times 6 \times 4\pi \times 10^{-12} \times [1 - 0.0081] \times 10^{12}$
 $= 0.3 \times 6 \times 4 \times 3.14 \times 9919 \times 10^{-4}$
 $= 4 \times 18 \times 3.14 \times 9919 \times 10^{-5} = 22.4 \approx 22 \text{ W}$
45. Since the Cube can be assumed as black body

$$e = 1$$

$$\sigma = 6 \times 10^{-8} \text{ w/m}^2\text{-k}^4$$

$$A = 6 \times 25 \times 10^{-4} \text{ m}^2$$

$$m = 1 \text{ kg}$$

$$s = 400 \text{ J/kg-}^\circ\text{K}$$

$$T_1 = 227^\circ\text{C} = 500 \text{ K}$$

$$T_2 = 27^\circ\text{C} = 300 \text{ K}$$

$$\Rightarrow ms \frac{d\theta}{dt} = e\sigma A(T_1^4 - T_2^4)$$

$$\Rightarrow \frac{d\theta}{dt} = \frac{e\sigma A(T_1^4 - T_2^4)}{ms}$$

$$= \frac{1 \times 6 \times 10^{-8} \times 6 \times 25 \times 10^{-4} \times [(500)^4 - (300)^4]}{1 \times 400}$$

$$= \frac{36 \times 25 \times 544}{400} \times 10^{-4} = 1224 \times 10^{-4} = 0.1224^\circ\text{C/s} \approx 0.12^\circ\text{C/s.}$$

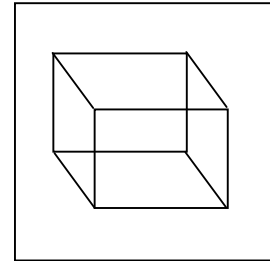

46. $Q = e\sigma A(T_2^4 - T_1^4)$
 For any body, $210 = eA\sigma[(500)^4 - (300)^4]$
 For black body, $700 = 1 \times A\sigma[(500)^4 - (300)^4]$
 Dividing $\frac{210}{700} = \frac{e}{1} \Rightarrow e = 0.3$

47. $A_A = 20 \text{ cm}^2, \quad A_B = 80 \text{ cm}^2$
 $(mS)_A = 42 \text{ J/}^\circ\text{C}, \quad (mS)_B = 82 \text{ J/}^\circ\text{C},$
 $T_A = 100^\circ\text{C}, \quad T_B = 20^\circ\text{C}$
 K_B is low thus it is a poor conductor and K_A is high.
 Thus A will absorb no heat and conduct all

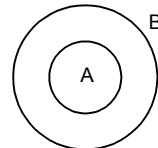

$$\left(\frac{E}{t}\right)_A = \sigma A_A [(373)^4 - (293)^4] \Rightarrow (mS)_A \left(\frac{d\theta}{dt}\right)_A = \sigma A_A [(373)^4 - (293)^4]$$

$$\Rightarrow \left(\frac{d\theta}{dt}\right)_A = \frac{\sigma A_A [(373)^4 - (293)^4]}{(mS)_A} = \frac{6 \times 10^{-8} [(373)^4 - (293)^4]}{42} = 0.03^\circ\text{C/S}$$

$$\text{Similarly } \left(\frac{d\theta}{dt}\right)_B = 0.043^\circ\text{C/S}$$

48. $\frac{Q}{t} = eAe(T_2^4 - T_1^4)$
 $\Rightarrow \frac{Q}{At} = 1 \times 6 \times 10^{-8} [(300)^4 - (290)^4] = 6 \times 10^{-8} (81 \times 10^8 - 70.7 \times 10^8) = 6 \times 10.3$
 $\frac{Q}{t} = \frac{KA(\theta_1 - \theta_2)}{l}$
 $\Rightarrow \frac{Q}{tA} = \frac{K(\theta_1 - \theta_2)}{l} = \frac{K \times 17}{0.5} = 6 \times 10.3 = \frac{K \times 17}{0.5} \Rightarrow K = \frac{6 \times 10.3 \times 0.5}{17} = 1.8$

49. $\sigma = 6 \times 10^{-8} \text{ w/m}^2\text{-k}^4$

$L = 20 \text{ cm} = 0.2 \text{ m}, \quad K = ?$

300 K

$$\Rightarrow E = \frac{KA(\theta_1 - \theta_2)}{d} = A\sigma(T_1^4 - T_2^4)$$

$$\Rightarrow K = \frac{s(T_1 - T_2) \times d}{\theta_1 - \theta_2} = \frac{6 \times 10^{-8} \times (750^4 - 300^4) \times 2 \times 10^{-1}}{50}$$

$$\Rightarrow K = 73.993 \approx 74.$$

50. $v = 100 \text{ cc}$

$\Delta\theta = 5^\circ\text{C}$

$t = 5 \text{ min}$

For water

$$\frac{mS\Delta\theta}{dt} = \frac{KA}{l} \Delta\theta$$

$$\Rightarrow \frac{100 \times 10^{-3} \times 1000 \times 4200}{5} = \frac{KA}{l}$$

For Kerosene

$$\frac{ms}{at} = \frac{KA}{l}$$

$$\Rightarrow \frac{100 \times 10^{-3} \times 800 \times 2100}{t} = \frac{KA}{l}$$

$$\Rightarrow \frac{100 \times 10^{-3} \times 800 \times 2100}{t} = \frac{100 \times 10^{-3} \times 1000 \times 4200}{5}$$

$$\Rightarrow T = \frac{5 \times 800 \times 2100}{1000 \times 4200} = 2 \text{ min}$$

51. 50°C 45°C 40°C

Let the surrounding temperature be ' T ' $^\circ\text{C}$

$$\text{Avg. } t = \frac{50 + 45}{2} = 47.5$$

Avg. temp. diff. from surrounding

$$T = 47.5 - T$$

$$\text{Rate of fall of temp} = \frac{50 - 45}{5} = 1^\circ\text{C/mm}$$

From Newton's Law

$$1^\circ\text{C/mm} = bA \times t$$

$$\Rightarrow bA = \frac{1}{t} = \frac{1}{47.5 - T} \quad \dots(1)$$

In second case,

$$\text{Avg. temp} = \frac{40 + 45}{2} = 42.5$$

Avg. temp. diff. from surrounding

$$t' = 42.5 - t$$

$$\text{Rate of fall of temp} = \frac{45 - 40}{8} = \frac{5}{8}^\circ\text{C/mm}$$

From Newton's Law

$$\frac{5}{8} = bAt'$$

$$\Rightarrow \frac{5}{8} = \frac{1}{(47.5 - T)} \times (42.5 - T)$$

By C & D [Componendo & Dividendo method]

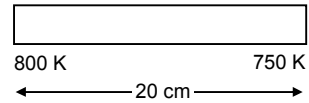
We find, $T = 34.1^\circ\text{C}$ 

52. Let the water eq. of calorimeter = m

$$\frac{(m + 50 \times 10^{-3}) \times 4200 \times 5}{10} = \text{Rate of heat flow}$$

$$\frac{(m + 100 \times 10^{-3}) \times 4200 \times 5}{18} = \text{Rate of flow}$$

$$\Rightarrow \frac{(m + 50 \times 10^{-3}) \times 4200 \times 5}{10} = \frac{(m + 100 \times 10^{-3}) \times 4200 \times 5}{18}$$

$$\Rightarrow (m + 50 \times 10^{-3})18 = 10m + 1000 \times 10^{-3}$$

$$\Rightarrow 18m + 18 \times 50 \times 10^{-3} = 10m + 1000 \times 10^{-3}$$

$$\Rightarrow 8m = 100 \times 10^{-3} \text{ kg}$$

$$\Rightarrow m = 12.5 \times 10^{-3} \text{ kg} = 12.5 \text{ g}$$

53. In steady state condition as no heat is absorbed, the rate of loss of heat by conduction is equal to that of the supplied.

i.e. $H = P$

$m = 1 \text{ Kg}$, Power of Heater = 20 W, Room Temp. = 20°C

$$(a) H = \frac{d\theta}{dt} = P = 20 \text{ watt}$$

(b) by Newton's law of cooling

$$\frac{-d\theta}{dt} = K(\theta - \theta_0)$$

$$-20 = K(50 - 20) \Rightarrow K = 2/3$$

$$\text{Again, } \frac{-d\theta}{dt} = K(\theta - \theta_0) = \frac{2}{3} \times (30 - 20) = \frac{20}{3} \text{ w}$$

$$(c) \left(\frac{dQ}{dt}\right)_{20} = 0, \quad \left(\frac{dQ}{dt}\right)_{30} = \frac{20}{3}, \quad \left(\frac{dQ}{dt}\right)_{\text{avg}} = \frac{10}{3}$$

$$T = 5 \text{ min} = 300'$$

$$\text{Heat liberated} = \frac{10}{3} \times 300 = 1000 \text{ J}$$

$$\text{Net Heat absorbed} = \text{Heat supplied} - \text{Heat Radiated} = 6000 - 1000 = 5000 \text{ J}$$

Now, $m\Delta\theta' = 5000$

$$\Rightarrow S = \frac{5000}{m\Delta\theta} = \frac{5000}{1 \times 10} = 500 \text{ J Kg}^{-1}\text{C}^{-1}$$

54. Given:

Heat capacity = $m \times s = 80 \text{ J}^\circ\text{C}$

$$\left(\frac{d\theta}{dt}\right)_{\text{increase}} = 2 \text{ }^\circ\text{C/s}$$

$$\left(\frac{d\theta}{dt}\right)_{\text{decrease}} = 0.2 \text{ }^\circ\text{C/s}$$

$$(a) \text{ Power of heater} = mS\left(\frac{d\theta}{dt}\right)_{\text{increasing}} = 80 \times 2 = 160 \text{ W}$$

$$(b) \text{ Power radiated} = mS\left(\frac{d\theta}{dt}\right)_{\text{decreasing}} = 80 \times 0.2 = 16 \text{ W}$$

$$(c) \text{ Now } mS\left(\frac{d\theta}{dt}\right)_{\text{decreasing}} = K(T - T_0)$$

$$\Rightarrow 16 = K(30 - 20) \quad \Rightarrow K = \frac{16}{10} = 1.6$$

$$\text{Now, } \frac{d\theta}{dt} = K(T - T_0) = 1.6 \times (30 - 25) = 1.6 \times 5 = 8 \text{ W}$$

$$(d) P.t = H \Rightarrow 8 \times t$$

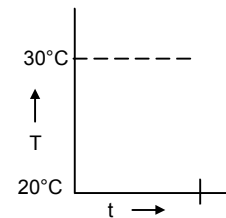

$$55. \frac{d\theta}{dt} = -K(T - T_0)$$

Temp. at $t = 0$ is θ_1

(a) Max. Heat that the body can lose = $\Delta Q_m = ms(\theta_1 - \theta_0)$

(\therefore as, $\Delta t = \theta_1 - \theta_0$)

(b) if the body loses 90% of the max heat the decrease in its temp. will be

$$\frac{\Delta Q_m \times 9}{10ms} = \frac{(\theta_1 - \theta_0) \times 9}{10}$$

If it takes time t_1 , for this process, the temp. at t_1

$$= \theta_1 - (\theta_1 - \theta_0) \frac{9}{10} = \frac{10\theta_1 - 9\theta_1 - 9\theta_0}{10} = \frac{\theta_1 - 9\theta_0}{10} \times 1$$

$$\text{Now, } \frac{d\theta}{dt} = -K(\theta - \theta_1)$$

Let $\theta = \theta_1$ at $t = 0$; & θ be temp. at time t

$$\int_{\theta}^{\theta_1} \frac{d\theta}{\theta - \theta_0} = -K \int_0^t dt$$

$$\text{or, } \ln \frac{\theta - \theta_0}{\theta_1 - \theta_0} = -Kt$$

$$\text{or, } \theta - \theta_0 = (\theta_1 - \theta_0) e^{-Kt} \quad \dots(2)$$

Putting value in the Eq (1) and Eq (2)

$$\frac{\theta_1 - 9\theta_0}{10} - \theta_0 = (\theta_1 - \theta_0) e^{-Kt}$$

$$\Rightarrow t_1 = \frac{\ln 10}{k}$$

♣ ♣ ♣ ♣ ♣

CHAPTER – 29
ELECTRIC FIELD AND POTENTIAL
EXERCISES

1. $\epsilon_0 = \frac{\text{Coulomb}^2}{\text{Newton m}^2} = 1^1 \text{M}^{-1} \text{L}^{-3} \text{T}^4$

$\therefore F = \frac{kq_1q_2}{r^2}$

2. $q_1 = q_2 = q = 1.0 \text{ C}$ distance between = $2 \text{ km} = 1 \times 10^3 \text{ m}$

so, force = $\frac{kq_1q_2}{r^2}$ $F = \frac{(9 \times 10^9) \times 1 \times 1}{(2 \times 10^3)^2} = \frac{9 \times 10^9}{2^2 \times 10^6} = 2,25 \times 10^3 \text{ N}$

The weight of body = $mg = 40 \times 10 \text{ N} = 400 \text{ N}$

So, $\frac{\text{wt of body}}{\text{force between charges}} = \left(\frac{2.25 \times 10^3}{4 \times 10^2} \right)^{-1} = (5.6)^{-1} = \frac{1}{5.6}$

So, force between charges = 5.6 weight of body.

3. $q = 1 \text{ C}$, Let the distance be χ

$F = 50 \times 9.8 = 490$

$F = \frac{Kq^2}{\chi^2} \Rightarrow 490 = \frac{9 \times 10^9 \times 1^2}{\chi^2}$ or $\chi^2 = \frac{9 \times 10^9}{490} = 18.36 \times 10^6$

$\Rightarrow \chi = 4.29 \times 10^3 \text{ m}$

4. charges 'q' each, $AB = 1 \text{ m}$

wt, of 50 kg person = $50 \times g = 50 \times 9.8 = 490 \text{ N}$

$F_c = \frac{kq_1q_2}{r^2}$ $\therefore \frac{kq^2}{r^2} = 490 \text{ N}$

$\Rightarrow q^2 = \frac{490 \times r^2}{9 \times 10^9} = \frac{490 \times 1 \times 1}{9 \times 10^9}$

$\Rightarrow q = \sqrt{54.4 \times 10^{-9}} = 23.323 \times 10^{-5} \text{ coulomb} \approx 2.3 \times 10^{-4} \text{ coulomb}$

5. Charge on each proton = $a = 1.6 \times 10^{-19} \text{ coulomb}$

Distance between charges = $10 \times 10^{-15} \text{ metre} = r$

Force = $\frac{kq^2}{r^2} = \frac{9 \times 10^9 \times 1.6 \times 1.6 \times 10^{-38}}{10^{-30}} = 9 \times 2.56 \times 10 = 230.4 \text{ Newton}$

6. $q_1 = 2.0 \times 10^{-6}$ $q_2 = 1.0 \times 10^{-6}$ $r = 10 \text{ cm} = 0.1 \text{ m}$

Let the charge be at a distance x from q_1

$F_1 = \frac{Kq_1q}{\chi^2}$ $F_2 = \frac{kqq_2}{(0.1-\chi)^2}$
 $= \frac{9.9 \times 2 \times 10^{-6} \times 10^9 \times q}{\chi^2}$

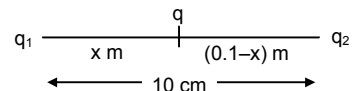

Now since the net force is zero on the charge q . $\Rightarrow f_1 = f_2$

$\Rightarrow \frac{kq_1q}{\chi^2} = \frac{kqq_2}{(0.1-\chi)^2}$

$\Rightarrow 2(0.1-\chi)^2 = \chi^2 \Rightarrow \sqrt{2}(0.1-\chi) = \chi$

$\Rightarrow \chi = \frac{0.1\sqrt{2}}{1+\sqrt{2}} = 0.0586 \text{ m} = 5.86 \text{ cm} \approx 5.9 \text{ cm}$ From larger charge

7. $q_1 = 2 \times 10^{-6} \text{ c}$ $q_2 = -1 \times 10^{-6} \text{ c}$ $r = 10 \text{ cm} = 10 \times 10^{-2} \text{ m}$

Let the third charge be a so, $F_{-AC} = -F_{-BC}$

$$\Rightarrow \frac{kQq_1}{r_1^2} = \frac{-KQq_2}{r_2^2} \quad \Rightarrow \frac{2 \times 10^{-6}}{(10 + \chi)^2} = \frac{1 \times 10^{-6}}{\chi^2}$$

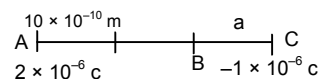

$$\Rightarrow 2\chi^2 = (10 + \chi)^2 \Rightarrow \sqrt{2} \chi = 10 + \chi \Rightarrow \chi(\sqrt{2} - 1) = 10 \Rightarrow \chi = \frac{-10}{1.414 - 1} = 24.14 \text{ cm}$$

So, distance = 24.14 + 10 = 34.14 cm from larger charge

8. Minimum charge of a body is the charge of an electron

Wo, $q = 1.6 \times 10^{-19} \text{ c}$ $\chi = 1 \text{ cm} = 1 \times 10^{-2} \text{ cm}$

$$\text{So, } F = \frac{kq_1q_2}{r^2} = \frac{9 \times 10^9 \times 1.6 \times 1.6 \times 10^{-19} \times 10^{-19}}{10^{-2} \times 10^{-2}} = 23.04 \times 10^{-38+9+2+2} = 23.04 \times 10^{-25} = 2.3 \times 10^{-24}$$

9. No. of electrons of 100 g water = $\frac{10 \times 100}{18} = 55.5 \text{ Nos}$ Total charge = 55.5

No. of electrons in 18 g of H₂O = $6.023 \times 10^{23} \times 10 = 6.023 \times 10^{24}$

No. of electrons in 100 g of H₂O = $\frac{6.023 \times 10^{24} \times 100}{18} = 0.334 \times 10^{26} = 3.334 \times 10^{25}$

Total charge = $3.34 \times 10^{25} \times 1.6 \times 10^{-19} = 5.34 \times 10^6 \text{ c}$

10. Molecular weight of H₂O = $2 \times 1 \times 16 = 16$

No. of electrons present in one molecule of H₂O = 10

18 gm of H₂O has 6.023×10^{23} molecule

18 gm of H₂O has $6.023 \times 10^{23} \times 10$ electrons

100 gm of H₂O has $\frac{6.023 \times 10^{24}}{18} \times 100$ electrons

So number of protons = $\frac{6.023 \times 10^{26}}{18}$ protons (since atom is electrically neutral)

Charge of protons = $\frac{1.6 \times 10^{-19} \times 6.023 \times 10^{26}}{18}$ coulomb = $\frac{1.6 \times 6.023 \times 10^7}{18}$ coulomb

Charge of electrons = $\frac{1.6 \times 6.023 \times 10^7}{18}$ coulomb

Hence Electrical force = $\frac{9 \times 10^9 \left(\frac{1.6 \times 6.023 \times 10^7}{18} \right) \times \left(\frac{1.6 \times 6.023 \times 10^7}{18} \right)}{(10 \times 10^{-2})^2}$

= $\frac{8 \times 6.023}{18} \times 1.6 \times 6.023 \times 10^{25} = 2.56 \times 10^{25} \text{ Newton}$

11. Let two protons be at a distance be 13.8 femi

$$F = \frac{9 \times 10^9 \times 1.6 \times 10^{-38}}{(14.8)^2 \times 10^{-30}} = 1.2 \text{ N}$$

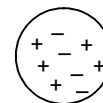

12. $F = 0.1 \text{ N}$

$r = 1 \text{ cm} = 10^{-2}$ (As they rubbed with each other. So the charge on each sphere are equal)

$$\text{So, } F = \frac{kq_1q_2}{r^2} \Rightarrow 0.1 = \frac{kq^2}{(10^{-2})^2} \Rightarrow q^2 = \frac{0.1 \times 10^{-4}}{9 \times 10^9} \Rightarrow q^2 = \frac{1}{9} \times 10^{-14} \Rightarrow q = \frac{1}{3} \times 10^{-7}$$

$1.6 \times 10^{-19} \text{ c}$ Carries by 1 electron 1 c carried by $\frac{1}{1.6 \times 10^{-19}}$

$0.33 \times 10^{-7} \text{ c}$ carries by $\frac{1}{1.6 \times 10^{-19}} \times 0.33 \times 10^{-7} = 0.208 \times 10^{12} = 2.08 \times 10^{11}$

$$13. F = \frac{kq_1q_2}{r^2} = \frac{9 \times 10^9 \times 1.6 \times 1.6 \times 10^{-19} \times 10^{-19}}{(2.75 \times 10^{-10})^2} = \frac{23.04 \times 10^{-29}}{7.56 \times 10^{-20}} = 3.04 \times 10^{-9}$$

14. Given: mass of proton = 1.67×10^{-27} kg = M_p
 $k = 9 \times 10^9$ Charge of proton = 1.6×10^{-19} c = C_p
 $G = 6.67 \times 10^{-11}$ Let the separation be 'r'

$$F_e = \frac{k(C_p)^2}{r^2}, \quad f_g = \frac{G(M_p)^2}{r^2}$$

$$\text{Now, } F_e : F_g = \frac{K(C_p)^2}{r^2} \times \frac{r^2}{G(M_p)^2} = \frac{9 \times 10^9 \times (1.6 \times 10^{-19})^2}{6.67 \times 10^{-11} \times (1.67 \times 10^{-27})^2} = 9 \times 2.56 \times 10^{38} \approx 1,24 \times 10^{38}$$

15. Expression of electrical force $F = C \times e^{-kr}$

Since e^{-kr} is a pure number. So, dimensional formulae of $F = \frac{\text{dimensional formulae of } C}{\text{dimensional formulae of } r^2}$

Or, $[MLT^{-2}][L^2] = \text{dimensional formulae of } C = [ML^3T^{-2}]$

Unit of C = unit of force \times unit of $r^2 = \text{Newton} \times m^2 = \text{Newton-m}^2$

Since $-kr$ is a number hence dimensional formulae of

$$k = \frac{1}{\text{dimensional formulae of } r} = [L^{-1}] \quad \text{Unit of } k = m^{-1}$$

16. Three charges are held at three corners of an equilateral triangle.

Let the charges be A, B and C. It is of length 5 cm or 0.05 m

Force exerted by B on A = F_1 force exerted by C on A = F_2

So, force exerted on A = resultant $F_1 = F_2$

$$\Rightarrow F = \frac{kq_2}{r^2} = \frac{9 \times 10^9 \times 2 \times 2 \times 2 \times 10^{-12}}{5 \times 5 \times 10^{-4}} = \frac{36}{25} \times 10 = 14.4$$

Now, force on A = $2 \times F \cos 30^\circ$ since it is equilateral Δ .

$$\Rightarrow \text{Force on A} = 2 \times 1.44 \times \frac{\sqrt{3}}{2} = 24.94 \text{ N.}$$

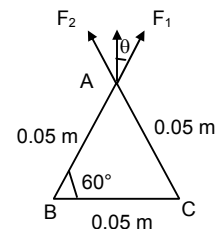

17. $q_1 = q_2 = q_3 = q_4 = 2 \times 10^{-6}$ C

$v = 5 \text{ cm} = 5 \times 10^{-2}$ m

so force on c = $\vec{F}_{CA} + \vec{F}_{CB} + \vec{F}_{CD}$

so Force along \times Component = $\vec{F}_{CD} + \vec{F}_{CA} \cos 45^\circ + 0$

$$= \frac{k(2 \times 10^{-6})^2}{(5 \times 10^{-2})^2} + \frac{k(2 \times 10^{-6})^2}{(5 \times 10^{-2})^2} \frac{1}{2\sqrt{2}} = kq^2 \left(\frac{1}{25 \times 10^{-4}} + \frac{1}{50\sqrt{2} \times 10^{-4}} \right)$$

$$= \frac{9 \times 10^9 \times 4 \times 10^{-12}}{24 \times 10^{-4}} \left(1 + \frac{1}{2\sqrt{2}} \right) = 1.44 (1.35) = 19.49 \text{ Force along } \times \text{ component} = 19.49$$

So, Resultant $R = \sqrt{F_x^2 + F_y^2} = 19.49 \sqrt{2} = 27.56$

18. $R = 0.53 \text{ A}^\circ = 0.53 \times 10^{-10}$ m

$$F = \frac{Kq_1q_2}{r^2} = \frac{9 \times 10^9 \times 1.6 \times 1.6 \times 10^{-38}}{0.53 \times 0.53 \times 10^{-10} \times 10^{-10}} = 82.02 \times 10^{-9} \text{ N}$$

19. F_e from previous problem No. 18 = 8.2×10^{-8} N $V_e = ?$

Now, $M_e = 9.12 \times 10^{-31}$ kg $r = 0.53 \times 10^{-10}$ m

$$\text{Now, } F_e = \frac{M_e v^2}{r} \Rightarrow v^2 = \frac{F_e \times r}{m_e} = \frac{8.2 \times 10^{-8} \times 0.53 \times 10^{-10}}{9.1 \times 10^{-31}} = 0.4775 \times 10^{13} = 4.775 \times 10^{12} \text{ m}^2/\text{s}^2$$

$$\Rightarrow v = 2.18 \times 10^6 \text{ m/s}$$

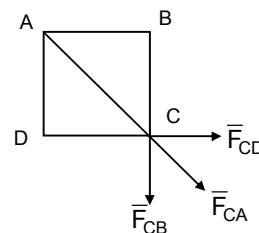

20. Electric force feeled by 1 c due to 1×10^{-8} c.

$$F_1 = \frac{k \times 1 \times 10^{-8} \times 1}{(10 \times 10^{-2})^2} = k \times 10^{-6} \text{ N.} \quad \text{electric force feeled by 1 c due to } 8 \times 10^{-8} \text{ c.}$$

$$F_2 = \frac{k \times 8 \times 10^{-8} \times 1}{(23 \times 10^{-2})^2} = \frac{k \times 8 \times 10^{-8} \times 10^2}{9} = \frac{28k \times 10^{-6}}{4} = 2k \times 10^{-6} \text{ N.}$$

$$\text{Similarly } F_3 = \frac{k \times 27 \times 10^{-8} \times 1}{(30 \times 10^{-2})^2} = 3k \times 10^{-6} \text{ N}$$

$$\text{So, } F = F_1 + F_2 + F_3 + \dots + F_{10} = k \times 10^{-6} (1 + 2 + 3 + \dots + 10) \text{ N}$$

$$= k \times 10^{-6} \times \frac{10 \times 11}{2} = 55k \times 10^{-6} = 55 \times 9 \times 10^9 \times 10^{-6} \text{ N} = 4.95 \times 10^3 \text{ N}$$

21. Force exerted = $\frac{kq_1^2}{r^2}$

$$= \frac{9 \times 10^9 \times 2 \times 2 \times 10^{-16}}{1^2} = 3.6 \times 10^{-6} \text{ is the force exerted on the string}$$

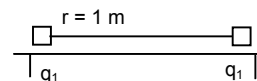

22. $q_1 = q_2 = 2 \times 10^{-7}$ c $m = 100$ g
 $l = 50$ cm = 5×10^{-2} m $d = 5 \times 10^{-2}$ m

(a) Now Electric force

$$F = K \frac{q_1^2}{r^2} = \frac{9 \times 10^9 \times 4 \times 10^{-14}}{25 \times 10^{-4}} \text{ N} = 14.4 \times 10^{-2} \text{ N} = 0.144 \text{ N}$$

(b) The components of Resultant force along it is zero, because mg balances $T \cos \theta$ and so also.

$$F = mg = T \sin \theta$$

(c) Tension on the string

$$T \sin \theta = F \quad T \cos \theta = mg$$

$$\tan \theta = \frac{F}{mg} = \frac{0.144}{100 \times 10^{-3} \times 9.8} = 0.14693$$

$$\text{But } T \cos \theta = 10^2 \times 10^{-3} \times 10 = 1 \text{ N}$$

$$\Rightarrow T = \frac{1}{\cos \theta} = \sec \theta$$

$$\Rightarrow T = \frac{F}{\sin \theta},$$

$$\sin \theta = 0.145369; \quad \cos \theta = 0.989378;$$

23. $q = 2.0 \times 10^{-8}$ c $n = ?$ $T = ?$ $\sin \theta = \frac{1}{20}$

Force between the charges

$$F = \frac{Kq_1q_2}{r^2} = \frac{9 \times 10^9 \times 2 \times 10^{-8} \times 2 \times 10^{-8}}{(3 \times 10^{-2})^2} = 4 \times 10^{-3} \text{ N}$$

$$mg \sin \theta = F \Rightarrow m = \frac{F}{g \sin \theta} = \frac{4 \times 10^{-3}}{10 \times (1/20)} = 8 \times 10^{-3} = 8 \text{ mg}$$

$$\cos \theta = \sqrt{1 - \sin^2 \theta} = \sqrt{1 - \frac{1}{400}} = \sqrt{\frac{400 - 1}{400}} = 0.99 \approx 1$$

$$\text{So, } T = mg \cos \theta$$

$$\text{Or } T = 8 \times 10^{-3} \times 10 \times 0.99 = 8 \times 10^{-2} \text{ M}$$

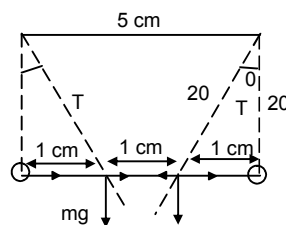
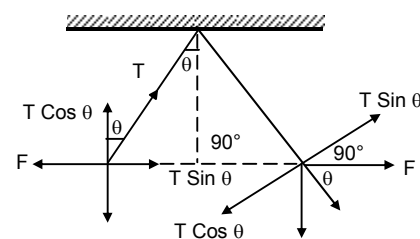

24. $T \cos \theta = mg \dots(1)$
 $T \sin \theta = Fe \dots(2)$

Solving, (2)/(1) we get, $\tan \theta = \frac{Fe}{mg} = \frac{kq^2}{r} \times \frac{1}{mg}$

$\Rightarrow \frac{2}{\sqrt{1596}} = \frac{9 \times 10^9 \times q^2}{(0.04)^2 \times 0.02 \times 9.8}$

$\Rightarrow q^2 = \frac{(0.04)^2 \times 0.02 \times 9.8 \times 2}{9 \times 10^9 \times \sqrt{1596}} = \frac{6.27 \times 10^{-4}}{9 \times 10^9 \times 39.95} = 17 \times 10^{-16} \text{C}^2$

$\Rightarrow q = \sqrt{17 \times 10^{-16}} = 4.123 \times 10^{-8} \text{C}$

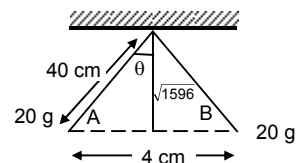

25. Electric force = $\frac{kq^2}{(\ell \sin Q + \ell \sin Q)^2} = \frac{kq^2}{4\ell^2 \sin^2}$

So, $T \cos \theta = ms$ (For equilibrium) $T \sin \theta = Ef$

Or $\tan \theta = \frac{Ef}{mg}$

$\Rightarrow mg = Ef \cot \theta = \frac{kq^2}{4\ell^2 \sin^2 \theta} \cot \theta = \frac{q^2 \cot \theta}{\ell^2 \sin^2 \theta 16\pi\epsilon_0}$

or $m = \frac{q^2 \cot \theta}{16\pi\epsilon_0 \ell^2 \sin^2 \theta g}$ unit.

26. Mass of the bob = 100 g = 0.1 kg

So Tension in the string = $0.1 \times 9.8 = 0.98 \text{N}$.

For the Tension to be 0, the charge below should repel the first bob.

$\Rightarrow F = \frac{kq_1q_2}{r^2} \quad T - mg + F = 0 \Rightarrow T = mg - f \quad T = mg$

$\Rightarrow 0.98 = \frac{9 \times 10^9 \times 2 \times 10^{-4} \times q_2}{(0.01)^2} \Rightarrow q_2 = \frac{0.98 \times 1 \times 10^{-2}}{9 \times 2 \times 10^5} = 0.054 \times 10^{-9} \text{N}$

27. Let the charge on C = q

So, net force on c is equal to zero

So $F_{AC} + F_{BA} = 0$, But $F_{AC} = F_{BC} \Rightarrow \frac{kqQ}{x^2} = \frac{k2qQ}{(d-x)^2}$

$\Rightarrow 2x^2 = (d-x)^2 \Rightarrow \sqrt{2} x = d-x$

$\Rightarrow x = \frac{d}{\sqrt{2}+1} = \frac{d}{(\sqrt{2}+1)} \times \frac{(\sqrt{2}-1)}{(\sqrt{2}-1)} = d(\sqrt{2}-1)$

For the charge on rest, $F_{AC} + F_{AB} = 0$

$(2.414)^2 \frac{kqQ}{d^2} + \frac{kq(2q)}{d^2} = 0 \Rightarrow \frac{kq}{d^2} [(2.414)^2 Q + 2q] = 0$

$\Rightarrow 2q = -(2.414)^2 Q$

$\Rightarrow Q = \frac{2}{-(\sqrt{2}+1)^2} q = -\left(\frac{2}{3+2\sqrt{2}}\right) q = -(0.343) q = -(6-4\sqrt{2})$

28. $K = 100 \text{N/m} \quad \ell = 10 \text{cm} = 10^{-1} \text{m} \quad q = 2.0 \times 10^{-8} \text{C}$ Find $\ell = ?$

Force between them $F = \frac{kq_1q_2}{r^2} = \frac{9 \times 10^9 \times 2 \times 10^{-8} \times 2 \times 10^{-8}}{10^{-2}} = 36 \times 10^{-5} \text{N}$

So, $F = -kx$ or $x = \frac{F}{-K} = \frac{36 \times 10^{-5}}{100} = 36 \times 10^{-7} \text{cm} = 3.6 \times 10^{-6} \text{m}$

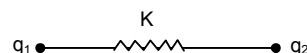
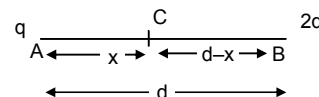
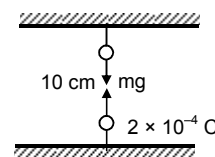
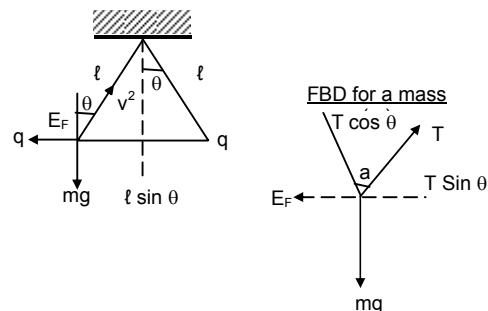

29. $q_A = 2 \times 10^{-6} \text{ C}$ $M_b = 80 \text{ g}$ $\mu = 0.2$

Since B is at equilibrium, So, $F_e = \mu R$

$$\Rightarrow \frac{Kq_A q_B}{r^2} = \mu R = \mu m \times g$$

$$\Rightarrow \frac{9 \times 10^9 \times 2 \times 10^{-6} \times q_B}{0.01} = 0.2 \times 0.08 \times 9.8$$

$$\Rightarrow q_B = \frac{0.2 \times 0.08 \times 9.8 \times 0.01}{9 \times 10^9 \times 2 \times 10^{-6}} = 8.7 \times 10^{-8} \text{ C} \quad \text{Range} = \pm 8.7 \times 10^{-8} \text{ C}$$

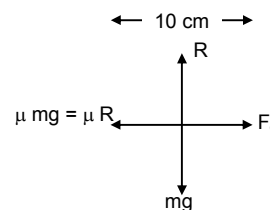

30. $q_1 = 2 \times 10^{-6} \text{ C}$ Let the distance be r unit

$$\therefore F_{\text{repulsion}} = \frac{kq_1 q_2}{r^2}$$

For equilibrium $\frac{kq_1 q_2}{r^2} = mg \sin \theta$

$$\Rightarrow \frac{9 \times 10^9 \times 4 \times 10^{-12}}{r^2} = m \times 9.8 \times \frac{1}{2}$$

$$\Rightarrow r^2 = \frac{18 \times 4 \times 10^{-3}}{m \times 9.8} = \frac{72 \times 10^{-3}}{9.8 \times 10^{-1}} = 7.34 \times 10^{-2} \text{ metre}$$

$$\Rightarrow r = 2.70924 \times 10^{-1} \text{ metre from the bottom.}$$

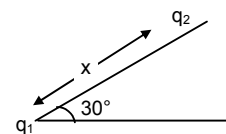

31. Force on the charge particle 'q' at 'c' is only the x component of 2 forces

So, $F_{\text{on c}} = F_{CB} \sin \theta + F_{AC} \sin \theta$ But $|F_{CB}| = |F_{AC}|$

$$= 2 F_{CB} \sin \theta = 2 \frac{KQq}{x^2 + (d/2)^2} \times \frac{x}{[x^2 + d^2/4]^{1/2}} = \frac{2k\theta qx}{(x^2 + d^2/4)^{3/2}} = \frac{16kQq}{(4x^2 + d^2)^{3/2}} x$$

For maximum force $\frac{dF}{dx} = 0$

$$\frac{d}{dx} \left(\frac{16kQqx}{(4x^2 + d^2)^{3/2}} \right) = 0 \Rightarrow K \left[\frac{(4x^2 + d^2) - x \left[3/2 [4x^2 + d^2]^{1/2} 8x \right]}{[4x^2 + d^2]^3} \right] = 0$$

$$\Rightarrow \frac{K(4x^2 + d^2)^{1/2} [(4x^2 + d^2)^3 - 12x^2]}{(4x^2 + d^2)^3} = 0 \Rightarrow (4x^2 + d^2)^3 = 12x^2$$

$$\Rightarrow 16x^4 + d^4 + 8x^2d^2 = 12x^2 \quad d^4 + 8x^2d^2 = 0$$

$$\Rightarrow d^2 = 0 \quad d^2 + 8x^2 = 0 \Rightarrow d^2 = 8x^2 \Rightarrow d = \frac{d}{2\sqrt{2}}$$

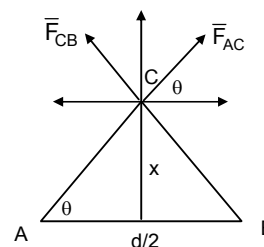

32. (a) Let $Q =$ charge on A & B Separated by distance d

$q =$ charge on c displaced \perp to $-AB$

So, force on $0 = \bar{F}_{AB} + \bar{F}_{BO}$

But $F_{AO} \cos \theta = F_{BO} \cos \theta$

So, force on 'O' in due to vertical component.

$$\bar{F} = F_{AO} \sin \theta + F_{BO} \sin \theta \quad |F_{AO}| = |F_{BO}|$$

$$= 2 \frac{KQq}{(d/2)^2 + x^2} \sin \theta \quad F = \frac{2KQq}{(d/2)^2 + x^2} \sin \theta$$

$$= \frac{4 \times 2 \times kQq}{(d^2 + 4x^2)} \times \frac{x}{[(d/2)^2 + x^2]^{1/2}} = \frac{2kQq}{[(d/2)^2 + x^2]^{3/2}} x = \text{Electric force} \Rightarrow F \propto x$$

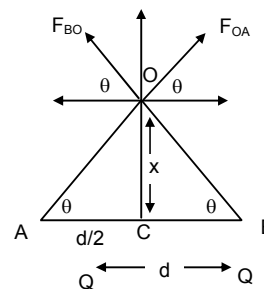

(b) When $x \ll d$ $F = \frac{2kQq}{[(d/2)^2 + x^2]^{3/2}} x$ $x \ll d$

$\Rightarrow F = \frac{2kQq}{(d^2/4)^{3/2}} x \Rightarrow F \propto x$ $a = \frac{F}{m} = \frac{1}{m} \left[\frac{2kQqx}{[(d^2/4) + \ell^2]} \right]$

So time period $T = 2\pi\sqrt{\frac{\ell}{g}} = 2\pi\sqrt{\frac{\ell}{a}}$

33. $F_{AC} = \frac{KQq}{(\ell+x)^2}$ $F_{CA} = \frac{KQq}{(\ell-x)^2}$

Net force = $KQq \left[\frac{1}{(\ell-x)^2} - \frac{1}{(\ell+x)^2} \right]$
 $= KQq \left[\frac{(\ell+x)^2 - (\ell-x)^2}{(\ell+x)^2(\ell-x)^2} \right] = KQq \left[\frac{4\ell x}{(\ell^2 - x^2)^2} \right]$

$x \ll \ell = d/2$ neglecting x w.r.t. ℓ We get

net $F = \frac{KQq4\ell x}{\ell^4} = \frac{KQq4x}{\ell^3}$ acceleration = $\frac{4KQqx}{m\ell^3}$

Time period = $2\pi\sqrt{\frac{\text{displacement}}{\text{acceleration}}} = 2\pi\sqrt{\frac{xm\ell^3}{4KQqx}} = 2\pi\sqrt{\frac{m\ell^3}{4KQq}}$
 $= \sqrt{\frac{4\pi^2 m\ell^3 4\pi\epsilon_0}{4Qq}} = \sqrt{\frac{4\pi^3 m\ell^3 \epsilon_0}{Qq}} = \sqrt{4\pi^3 md^3 \epsilon_0 8Qq} = \left[\frac{\pi^3 md^3 \epsilon_0}{2Qq} \right]^{1/2}$

34. $F_e = 1.5 \times 10^{-3}$ N, $q = 1 \times 10^{-6}$ C, $F_e = q \times E$

$\Rightarrow E = \frac{F_e}{q} = \frac{1.5 \times 10^{-3}}{1 \times 10^{-6}} = 1.5 \times 10^3$ N/C

35. $q_2 = 2 \times 10^{-6}$ C, $q_1 = -4 \times 10^{-6}$ C, $r = 20$ cm = 0.2 m
 (E_1 = electric field due to q_1 , E_2 = electric field due to q_2)

$\Rightarrow \frac{(r-x)^2}{x^2} = \frac{-q_2}{q_1} \Rightarrow \frac{(r-1)^2}{x} = \frac{-q_2}{q_1} = \frac{4 \times 10^{-6}}{2 \times 10^{-6}} = \frac{1}{2}$

$\Rightarrow \left(\frac{r}{x} - 1 \right) = \frac{1}{\sqrt{2}} = \frac{1}{1.414} \Rightarrow \frac{r}{x} = 1.414 + 1 = 2.414$

$\Rightarrow x = \frac{r}{2.414} = \frac{20}{2.414} = 8.285$ cm

36. $EF = \frac{KQ}{r^2}$

5 N/C = $\frac{9 \times 10^9 \times Q}{4^2}$

$\Rightarrow \frac{4 \times 20 \times 10^{-2}}{9 \times 10^9} = Q \Rightarrow Q = 8.88 \times 10^{-11}$

37. $m = 10$, $mg = 10 \times 10^{-3} \text{ g} \times 10^{-3} \text{ kg}$, $q = 1.5 \times 10^{-6}$ C

But $qE = mg \Rightarrow (1.5 \times 10^{-6}) E = 10 \times 10^{-6} \times 10$

$\Rightarrow E = \frac{10 \times 10^{-4} \times 10}{1.5 \times 10^{-6}} = \frac{100}{1.5} = 66.6$ N/C

$= \frac{100 \times 10^3}{1.5} = \frac{10^{5+1}}{15} = 6.6 \times 10^3$

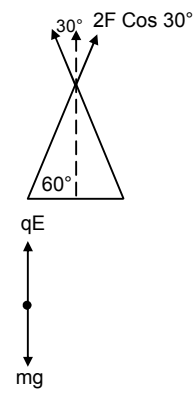
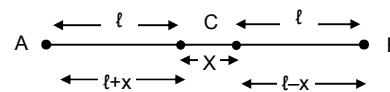

38. $q = 1.0 \times 10^{-8} \text{ C}$, $l = 20 \text{ cm}$
 $E = ?$ $V = ?$

Since it forms an equipotential surface.
 So the electric field at the centre is Zero.

$$r = \frac{2}{3} \sqrt{(2 \times 10^{-1})^2 - (10^{-1})^2} = \frac{2}{3} \sqrt{4 \times 10^{-2} - 10^{-2}}$$

$$= \frac{2}{3} \sqrt{10^{-2}(4-1)} = \frac{2}{3} \times 10^{-2} \times 1.732 = 1.15 \times 10^{-1}$$

$$V = \frac{3 \times 9 \times 10^9 \times 1 \times 10^{-8}}{1 \times 10^{-1}} = 23 \times 10^2 = 2.3 \times 10^3 \text{ V}$$

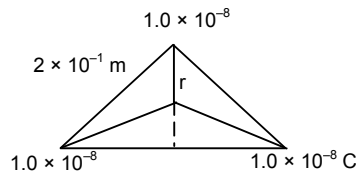

39. We know : Electric field 'E' at 'P' due to the charged ring

$$= \frac{KQx}{(R^2 + x^2)^{3/2}} = \frac{KQx}{R^3}$$

Force experienced 'F' = $Q \times E = \frac{q \times K \times Qx}{R^3}$

Now, amplitude = x

$$\text{So, } T = 2\pi \sqrt{\frac{x}{KQqx/mR^3}} = 2\pi \sqrt{\frac{mR^3x}{KQqx}} = 2\pi \sqrt{\frac{4\pi\epsilon_0 mR^3}{Qq}} = \sqrt{\frac{4\pi^2 \times 4\pi\epsilon_0 mR^3}{qQ}}$$

$$\Rightarrow T = \left[\frac{16\pi^3 \epsilon_0 mR^3}{qQ} \right]^{1/2}$$

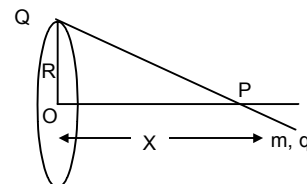

40. $\lambda = \text{Charge per unit length} = \frac{Q}{L}$

dq_1 for a length $d\ell = \lambda \times d\ell$

Electric field at the centre due to charge = $k \times \frac{dq}{r^2}$

The horizontal Components of the Electric field balances each other. Only the vertical components remain.

\therefore Net Electric field along vertical

$$dE = 2 E \cos \theta = \frac{Kdq \times \cos \theta}{r^2} = \frac{2k\text{Cos}\theta}{r^2} \times \lambda \times d\ell \quad [\text{but } d\theta = \frac{d\ell}{r} = d\ell = r d\theta]$$

$$\Rightarrow \frac{2k\lambda}{r^2} \text{Cos}\theta \times r d\theta = \frac{2k\lambda}{r} \text{Cos}\theta \times d\theta$$

$$\text{or } E = \int_0^{\pi/2} \frac{2k\lambda}{r} \text{Cos}\theta \times d\theta = \int_0^{\pi/2} \frac{2k\lambda}{r} \text{Sin}\theta = \frac{2k\lambda l}{r} = \frac{2K\theta}{Lr}$$

but $L = \pi R \Rightarrow r = \frac{L}{\pi}$

$$\text{So } E = \frac{2k\theta}{L \times (L/\pi)} = \frac{2k\pi\theta}{L^2} = \frac{2}{4\pi\epsilon_0} \times \frac{\pi\theta}{L^2} = \frac{\theta}{2\epsilon_0 L^2}$$

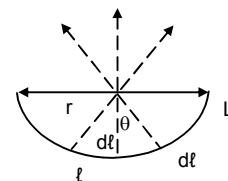

41. $G = 50 \mu\text{C} = 50 \times 10^{-6} \text{ C}$

We have, $E = \frac{2KQ}{r}$ for a charged cylinder.

$$\Rightarrow E = \frac{2 \times 9 \times 10^9 \times 50 \times 10^{-6}}{5\sqrt{3}} = \frac{9 \times 10^{-5}}{5\sqrt{3}} = 1.03 \times 10^{-5}$$

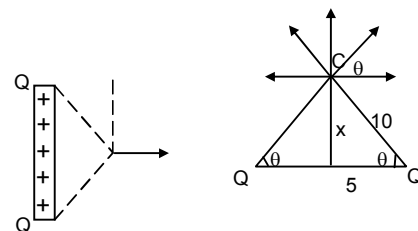

42. Electric field at any point on the axis at a distance x from the center of the ring is

$$E = \frac{xQ}{4\pi\epsilon_0(R^2 + x^2)^{3/2}} = \frac{KxQ}{(R^2 + x^2)^{3/2}}$$

Differentiating with respect to x

$$\frac{dE}{dx} = \frac{KQ(R^2 + x^2)^{3/2} - KxQ(3/2)(R^2 + x^2)^{1/2} \cdot 2x}{(R^2 + x^2)^3}$$

Since at a distance x, Electric field is maximum.

$$\begin{aligned} \frac{dE}{dx} = 0 &\Rightarrow KQ(R^2 + x^2)^{3/2} - Kx^2 Q3(R^2 + x^2)^{1/2} = 0 \\ \Rightarrow KQ(R^2 + x^2)^{3/2} &= Kx^2 Q3(R^2 + x^2)^{1/2} \Rightarrow R^2 + x^2 = 3x^2 \\ \Rightarrow 2x^2 &= R^2 \Rightarrow x^2 = \frac{R^2}{2} \Rightarrow x = \frac{R}{\sqrt{2}} \end{aligned}$$

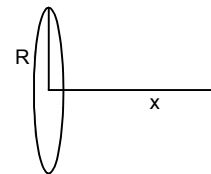

43. Since it is a regular hexagon. So, it forms an equipotential surface. Hence the charge at each point is equal. Hence the net entire field at the centre is Zero.

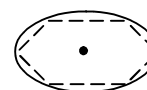

44. Charge/Unit length = $\frac{Q}{2\pi a} = \lambda$; Charge of $d\ell = \frac{Qd\ell}{2\pi a} C$

Initially the electric field was '0' at the centre. Since the element ' $d\ell$ ' is removed so, net electric field must

$$\frac{K \times q}{a^2} \quad \text{Where } q = \text{charge of element } d\ell$$

$$E = \frac{Kq}{a^2} = \frac{1}{4\pi\epsilon_0} \times \frac{Qd\ell}{2\pi a} \times \frac{1}{a^2} = \frac{Qd\ell}{8\pi^2\epsilon_0 a^3}$$

45. We know,

Electric field at a point due to a given charge

$$'E' = \frac{Kq}{r^2} \quad \text{Where } q = \text{charge, } r = \text{Distance between the point and the charge}$$

$$\text{So, 'E' = } \frac{1}{4\pi\epsilon_0} \times \frac{q}{d^2} \quad [\because r = 'd' \text{ here}]$$

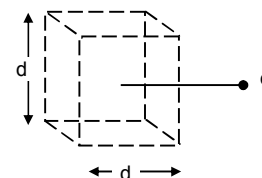

46. $E = 20 \text{ kv/m} = 20 \times 10^3 \text{ v/m}$, $m = 80 \times 10^{-5} \text{ kg}$, $c = 20 \times 10^{-5} \text{ C}$

$$\tan \theta = \left(\frac{qE}{mg} \right)^{-1} \quad [T \sin \theta = mg, T \cos \theta = qe]$$

$$\tan \theta = \left(\frac{2 \times 10^{-8} \times 20 \times 10^3}{80 \times 10^{-6} \times 10} \right)^{-1} = \left(\frac{1}{2} \right)^{-1}$$

$$1 + \tan^2 \theta = \frac{1}{4} + 1 = \frac{5}{4} \quad [\cos \theta = \frac{1}{\sqrt{5}}, \sin \theta = \frac{2}{\sqrt{5}}]$$

$$T \sin \theta = mg \Rightarrow T \times \frac{2}{\sqrt{5}} = 80 \times 10^{-6} \times 10$$

$$\Rightarrow T = \frac{8 \times 10^{-4} \times \sqrt{5}}{2} = 4 \times \sqrt{5} \times 10^{-4} = 8.9 \times 10^{-4}$$

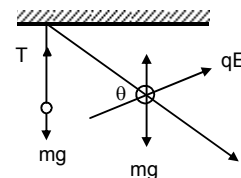
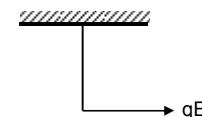

47. Given

$u =$ Velocity of projection, $\vec{E} =$ Electric field intensity

$q =$ Charge; $m =$ mass of particle

We know, Force experienced by a particle with charge ' q ' in an electric field $\vec{E} = q\vec{E}$

$$\therefore \text{acceleration produced} = \frac{q\vec{E}}{m}$$

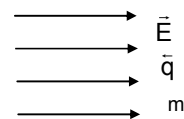

As the particle is projected against the electric field, hence deceleration = $\frac{qE}{m}$

So, let the distance covered be 's'

Then, $v^2 = u^2 + 2as$ [where a = acceleration, v = final velocity]

$$\text{Here } 0 = u^2 - 2 \times \frac{qE}{m} \times S \Rightarrow S = \frac{u^2 m}{2qE} \text{ units}$$

48. $m = 1 \text{ g} = 10^{-3} \text{ kg}$, $u = 0$, $q = 2.5 \times 10^{-4} \text{ C}$; $E = 1.2 \times 10^4 \text{ N/C}$; $S = 40 \text{ cm} = 4 \times 10^{-1} \text{ m}$

a) $F = qE = 2.5 \times 10^{-4} \times 1.2 \times 10^4 = 3 \text{ N}$

So, $a = \frac{F}{m} = \frac{3}{10^{-3}} = 3 \times 10^3$

$E_q = mg = 10^{-3} \times 9.8 = 9.8 \times 10^{-3} \text{ N}$

b) $S = \frac{1}{2} at^2$ or $t = \sqrt{\frac{2a}{g}} = \sqrt{\frac{2 \times 4 \times 10^{-1}}{3 \times 10^3}} = 1.63 \times 10^{-2} \text{ sec}$

$v^2 = u^2 + 2as = 0 + 2 \times 3 \times 10^3 \times 4 \times 10^{-1} = 24 \times 10^2 \Rightarrow v = \sqrt{24 \times 10^2} = 4.9 \times 10 = 49 \text{ m/sec}$

work done by the electric force $w = F \rightarrow td = 3 \times 4 \times 10^{-1} = 12 \times 10^{-1} = 1.2 \text{ J}$

49. $m = 100 \text{ g}$, $q = 4.9 \times 10^{-5}$, $F_g = mg$, $F_e = qE$

$\vec{E} = 2 \times 10^4 \text{ N/C}$

So, the particle moves due to the resultant R

$R = \sqrt{F_g^2 + F_e^2} = \sqrt{(0.1 \times 9.8)^2 + (4.9 \times 10^{-5} \times 2 \times 10^4)^2}$

$= \sqrt{0.9604 + 96.04 \times 10^{-2}} = \sqrt{1.9208} = 1.3859 \text{ N}$

$\tan \theta = \frac{F_g}{F_e} = \frac{mg}{qE} = 1$ So, $\theta = 45^\circ$

∴ Hence path is straight along resultant force at an angle 45° with horizontal

Disp. Vertical = $(1/2) \times 9.8 \times 2 \times 2 = 19.6 \text{ m}$

Disp. Horizontal = $S = (1/2) at^2 = \frac{1}{2} \times \frac{qE}{m} \times t^2 = \frac{1}{2} \times \frac{0.98}{0.1} \times 2 \times 2 = 19.6 \text{ m}$

Net Dispt. = $\sqrt{(19.6)^2 + (19.6)^2} = \sqrt{768.32} = 27.7 \text{ m}$

50. $m = 40 \text{ g}$, $q = 4 \times 10^{-6} \text{ C}$

Time for 20 oscillations = 45 sec. Time for 1 oscillation = $\frac{45}{20} \text{ sec}$

When no electric field is applied, $T = 2\pi\sqrt{\frac{l}{g}} \Rightarrow \frac{45}{20} = 2\pi\sqrt{\frac{l}{10}}$

$\Rightarrow \frac{l}{10} = \left(\frac{45}{20}\right)^2 \times \frac{1}{4\pi^2} \Rightarrow l = \frac{(45)^2 \times 10}{(20)^2 \times 4\pi^2} = 1.2836$

When electric field is not applied,

$T = 2\pi\sqrt{\frac{l}{g-a}}$ [$a = \frac{qE}{m} = 2.5$] = $2\pi\sqrt{\frac{1.2836}{10-2.5}} = 2.598$

Time for 1 oscillation = 2.598

Time for 20 oscillation = $2.598 \times 20 = 51.96 \text{ sec} \approx 52 \text{ sec}$.

51. $F = qE$, $F = -Kx$

Where x = amplitude

$qE = -Kx$ or $x = \frac{-qE}{K}$

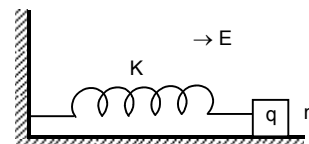
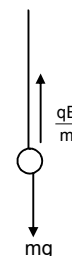
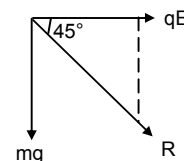
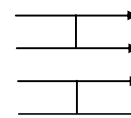

52. The block does not undergo SHM since here the acceleration is not proportional to displacement and not always opposite to displacement. When the block is going towards the wall the acceleration is along displacement and when going away from it the displacement is opposite to acceleration.

Time taken to go towards the wall is the time taken to go away from it till velocity is

$$d = ut + \frac{1}{2}at^2$$

$$\Rightarrow d = \frac{1}{2} \times \frac{qE}{m} \times t^2$$

$$\Rightarrow t^2 = \frac{2dm}{qE} \Rightarrow t = \sqrt{\frac{2md}{qE}}$$

\therefore Total time taken for to reach the wall and com back (Time period)

$$= 2t = 2\sqrt{\frac{2md}{qE}} = \sqrt{\frac{8md}{qE}}$$

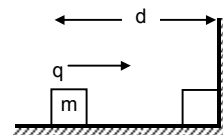

53. $E = 10 \text{ n/c}$, $S = 50 \text{ cm} = 0.1 \text{ m}$

$$E = \frac{dV}{dr} \text{ or, } V = E \times r = 10 \times 0.5 = 5 \text{ cm}$$

54. Now, $V_B - V_A = \text{Potential diff} = ?$ Charge = 0.01 C
Work done = 12 J Now, Work done = Pot. Diff \times Charge

$$\Rightarrow \text{Pot. Diff} = \frac{12}{0.01} = 1200 \text{ Volt}$$

55. When the charge is placed at A,

$$E_1 = \frac{Kq_1q_2}{r} + \frac{Kq_3q_4}{r}$$

$$= \frac{9 \times 10^9 (2 \times 10^{-7})^2}{0.1} + \frac{9 \times 10^9 (2 \times 10^{-7})^2}{0.1}$$

$$= \frac{2 \times 9 \times 10^9 \times 4 \times 10^{-14}}{0.1} = 72 \times 10^{-4} \text{ J}$$

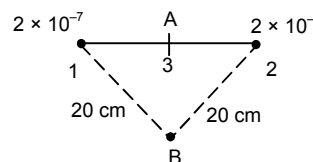

When charge is placed at B,

$$E_2 = \frac{Kq_1q_2}{r} + \frac{Kq_3q_4}{r} = \frac{2 \times 9 \times 10^9 \times 4 \times 10^{-14}}{0.2} = 36 \times 10^{-4} \text{ J}$$

$$\text{Work done} = E_1 - E_2 = (72 - 36) \times 10^{-4} = 36 \times 10^{-4} \text{ J} = 3.6 \times 10^{-3} \text{ J}$$

56. (a) $A = (0, 0)$ $B = (4, 2)$

$$V_B - V_A = E \times d = 20 \times \sqrt{16} = 80 \text{ V}$$

- (b) $A(4\text{m}, 2\text{m})$, $B = (6\text{m}, 5\text{m})$

$$\Rightarrow V_B - V_A = E \times d = 20 \times \sqrt{(6-4)^2} = 20 \times 2 = 40 \text{ V}$$

- (c) $A(0, 0)$ $B = (6\text{m}, 5\text{m})$

$$\Rightarrow V_B - V_A = E \times d = 20 \times \sqrt{(6-0)^2} = 20 \times 6 = 120 \text{ V.}$$

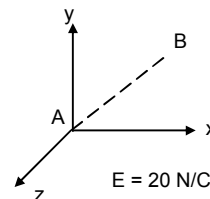

57. (a) The Electric field is along x-direction

Thus potential difference between $(0, 0)$ and $(4, 2)$ is,

$$\delta V = -E \times \delta x = -20 \times (4) = -80 \text{ V}$$

Potential energy $(U_B - U_A)$ between the points = $\delta V \times q$

$$= -80 \times (-2) \times 10^{-4} = 160 \times 10^{-4} = 0.016 \text{ J.}$$

- (b) $A = (4\text{m}, 2\text{m})$ $B = (6\text{m}, 5\text{m})$

$$\delta V = -E \times \delta x = -20 \times 2 = -40 \text{ V}$$

Potential energy $(U_B - U_A)$ between the points = $\delta V \times q$

$$= -40 \times (-2 \times 10^{-4}) = 80 \times 10^{-4} = 0.008 \text{ J}$$

- (c) $A = (0, 0)$ $B = (6\text{m}, 5\text{m})$

$$\delta V = -E \times \delta x = -20 \times 6 = -120 \text{ V}$$

Potential energy $(U_B - U_A)$ between the points A and B

$$= \delta V \times q = -120 \times (-2 \times 10^{-4}) = 240 \times 10^{-4} = 0.024 \text{ J}$$

58. $E = (\hat{i}20 + \hat{j}30) \text{ N/CV} = \text{at } (2\text{m}, 2\text{m}) \text{ } r = (2\hat{i} + 2\hat{j})$
 So, $V = -\vec{E} \times \vec{r} = -(i20 + j30) (2\hat{i} + 2\hat{j}) = -(2 \times 20 + 2 \times 30) = -100 \text{ V}$

59. $E = \vec{i} \times Ax = 100 \vec{i}$
 $\int_v^0 dv = -\int E \times d\ell \quad V = -\int_0^{10} 10x \times dx = -\int_0^{10} \frac{1}{2} \times 10 \times x^2$
 $0 - V = -\left[\frac{1}{2} \times 1000\right] = -500 \Rightarrow V = 500 \text{ Volts}$

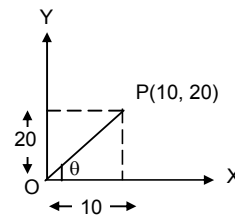

60. $V(x, y, z) = A(xy + yz + zx)$

(a) $A = \frac{\text{Volt}}{\text{m}^2} = \frac{\text{ML}^2\text{T}^{-2}}{\text{ITL}^2} = [\text{MT}^{-3}\text{I}^{-1}]$

(b) $E = -\left[\frac{\delta V \hat{i}}{\delta x} - \frac{\delta V \hat{j}}{\delta y} - \frac{\delta V \hat{k}}{\delta z}\right] = -\left[\frac{\delta}{\delta x}[A(xy + yz + zx)] + \frac{\delta}{\delta y}[A(xy + yz + zx)] + \frac{\delta}{\delta z}[A(xy + yz + zx)]\right]$
 $= -[(Ay + Az)\hat{i} + (Ax + Az)\hat{j} + (Ay + Ax)\hat{k}] = -A(y + z)\hat{i} + A(x + z)\hat{j} + A(y + x)\hat{k}$

(c) $A = 10 \text{ SI unit, } r = (1\text{m}, 1\text{m}, 1\text{m})$

$E = -10(2)\hat{i} - 10(2)\hat{j} - 10(2)\hat{k} = -20\hat{i} - 20\hat{j} - 20\hat{k} = \sqrt{20^2 + 20^2 + 20^2} = \sqrt{1200} = 34.64 \approx 35 \text{ N/C}$

61. $q_1 = q_2 = 2 \times 10^{-5} \text{ C}$
 Each are brought from infinity to 10 cm a part $d = 10 \times 10^{-2} \text{ m}$
 So work done = negative of work done. (Potential E)

$P.E = \int_{\infty}^{10} F \times ds \quad P.E. = K \times \frac{q_1 q_2}{r} = \frac{9 \times 10^9 \times 4 \times 10^{-10}}{10 \times 10^{-2}} = 36 \text{ J}$

62. (a) The angle between potential $E \, d\ell = dv$
 Change in potential = 10 V = dV
 As $E = \perp r \, dV$ (As potential surface)
 So, $E \, d\ell = dV \Rightarrow E \, d\ell \cos(90^\circ + 30^\circ) = -dV$
 $\Rightarrow E(10 \times 10^{-2}) \cos 120^\circ = -dV$

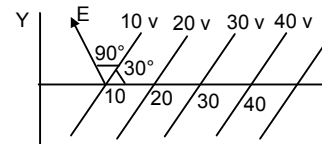

$\Rightarrow E = \frac{-dV}{10 \times 10^{-2} \cos 120^\circ} = -\frac{10}{10^{-1} \times (-1/2)} = 200 \text{ V/m}$ making an angle 120° with y-axis

(b) As Electric field intensity is $\perp r$ to Potential surface

So, $E = \frac{kq}{r^2} r = \frac{kq}{r} \Rightarrow \frac{kq}{r} = 60 \text{ v} \quad q = \frac{6}{K}$

So, $E = \frac{kq}{r^2} = \frac{6 \times k}{k \times r^2} \text{ v.m} = \frac{6}{r^2} \text{ v.m}$

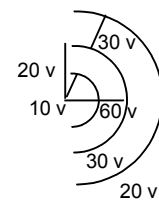

63. Radius = r So, $2\pi r = \text{Circumference}$

Charge density = λ Total charge = $2\pi r \times \lambda$

Electric potential = $\frac{Kq}{r} = \frac{1}{4\pi\epsilon_0} \times \frac{2\pi r\lambda}{(x^2 + r^2)^{1/2}} = \frac{r\lambda}{2\epsilon_0(x^2 + r^2)^{1/2}}$

So, Electric field = $\frac{V}{r} \cos\theta$

$= \frac{r\lambda}{2\epsilon_0(x^2 + r^2)^{1/2}} \times \frac{1}{(x^2 + r^2)^{1/2}}$

$= \frac{r\lambda}{2\epsilon_0(x^2 + r^2)^{1/2}} \times \frac{x}{(x^2 + r^2)^{1/2}} = \frac{r\lambda x}{2\epsilon_0(x^2 + r^2)^{3/2}}$

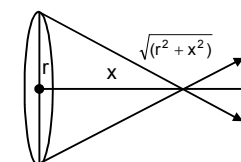

64. $\vec{E} = 1000 \text{ N/C}$

(a) $V = E \times d = 1000 \times \frac{2}{100} = 20 \text{ V}$

(b) $u = ? \quad \vec{E} = 1000, \quad = 2/100 \text{ m}$

$a = \frac{F}{m} = \frac{q \times E}{m} = \frac{1.6 \times 10^{-19} \times 1000}{9.1 \times 10^{-31}} = 1.75 \times 10^{14} \text{ m/s}^2$

$0 = u^2 - 2 \times 1.75 \times 10^{14} \times 0.02 \Rightarrow u^2 = 0.04 \times 1.75 \times 10^{14} \Rightarrow u = 2.64 \times 10^6 \text{ m/s.}$

(c) Now, $U = u \cos 60^\circ \quad V = 0, \quad s = ?$

$a = 1.75 \times 10^{14} \text{ m/s}^2 \quad V^2 = u^2 - 2as$

$\Rightarrow s = \frac{(u \cos 60^\circ)^2}{2 \times a} = \frac{\left(2.64 \times 10^6 \times \frac{1}{2}\right)^2}{2 \times 1.75 \times 10^{14}} = \frac{1.75 \times 10^{12}}{3.5 \times 10^{14}} = 0.497 \times 10^{-2} \approx 0.005 \text{ m} \approx 0.50 \text{ cm}$

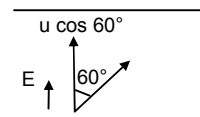
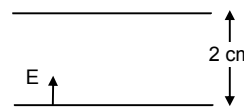

65. $E = 2 \text{ N/C}$ in x-direction

(a) Potential at the origin is 0. $dV = -E_x dx - E_y dy - E_z dz$

$\Rightarrow V - 0 = -2x \Rightarrow V = -2x$

(b) $(25 - 0) = -2x \Rightarrow x = -12.5 \text{ m}$

(c) If potential at origin is 100 v, $v - 100 = -2x \Rightarrow V = -2x + 100 = 100 - 2x$

(d) Potential at ∞ is 0, $V - V' = -2x \Rightarrow V' = V + 2x = 0 + 2\infty \Rightarrow V' = \infty$

Potential at origin is ∞ . No, it is not practical to take potential at ∞ to be zero.

66. Amount of work done in assembling the charges is equal to the net potential energy

So, P.E. = $U_{12} + U_{13} + U_{23}$

$= \frac{Kq_1q_2}{r_{12}} + \frac{Kq_1q_3}{r_{13}} + \frac{Kq_2q_3}{r_{23}} = \frac{K \times 10^{-10}}{r} [4 \times 2 + 4 \times 3 + 3 \times 2]$

$= \frac{9 \times 10^9 \times 10^{-10}}{10^{-1}} (8 + 12 + 6) = 9 \times 26 = 234 \text{ J}$

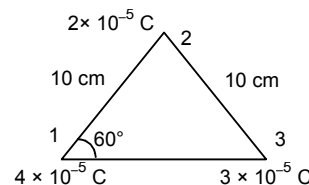

67. K.C. decreases by 10 J. Potential = 100 v to 200 v.

So, change in K.E = amount of work done

$\Rightarrow 10 \text{ J} = (200 - 100) \text{ v} \times q_0 \Rightarrow 100 q_0 = 10 \text{ v}$

$\Rightarrow q_0 = \frac{10}{100} = 0.1 \text{ C}$

68. $m = 10 \text{ g}; \quad F = \frac{KQ}{r} = \frac{9 \times 10^9 \times 2 \times 10^{-4}}{10 \times 10^{-2}} \quad F = 1.8 \times 10^{-7}$

$F = m \times a \Rightarrow a = \frac{1.8 \times 10^{-7}}{10 \times 10^{-3}} = 1.8 \times 10^{-3} \text{ m/s}^2$

$V^2 - u^2 = 2as \Rightarrow V^2 = u^2 + 2as$

$V = \sqrt{0 + 2 \times 1.8 \times 10^{-3} \times 10 \times 10^{-2}} = \sqrt{3.6 \times 10^{-4}} = 0.6 \times 10^{-2} = 6 \times 10^{-3} \text{ m/s.}$

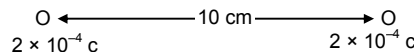

69. $q_1 = q_2 = 4 \times 10^{-5}$; $s = 1 \text{ m}, m = 5 \text{ g} = 0.005 \text{ kg}$

$F = K \frac{q^2}{r^2} = \frac{9 \times 10^9 \times (4 \times 10^{-5})^2}{1^2} = 14.4 \text{ N}$

Acceleration 'a' = $\frac{F}{m} = \frac{14.4}{0.005} = 2880 \text{ m/s}^2$

Now $u = 0, \quad s = 50 \text{ cm} = 0.5 \text{ m}, \quad a = 2880 \text{ m/s}^2, \quad V = ?$

$V^2 = u^2 + 2as \Rightarrow V^2 = 2 \times 2880 \times 0.5$

$\Rightarrow V = \sqrt{2880} = 53.66 \text{ m/s} \approx 54 \text{ m/s}$ for each particle

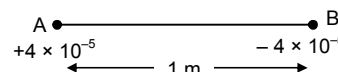

70. $E = 2.5 \times 10^4$ $P = 3.4 \times 10^{-30}$ $\tau = PE \sin \theta$
 $= P \times E \times 1 = 3.4 \times 10^{-30} \times 2.5 \times 10^4 = 8.5 \times 10^{-26}$

71. (a) Dipolemoment = $q \times \ell$
 (Where q = magnitude of charge ℓ = Separation between the charges)
 $= 2 \times 10^{-6} \times 10^{-2} \text{ cm} = 2 \times 10^{-8} \text{ cm}$

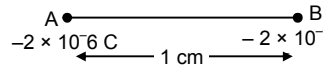

(b) We know, Electric field at an axial point of the dipole

$$= \frac{2KP}{r^3} = \frac{2 \times 9 \times 10^9 \times 2 \times 10^{-8}}{(1 \times 10^{-2})^3} = 36 \times 10^7 \text{ N/C}$$

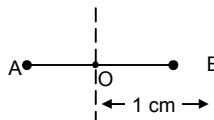

(c) We know, Electric field at a point on the perpendicular bisector about 1m away from centre of dipole.

$$= \frac{KP}{r^3} = \frac{9 \times 10^9 \times 2 \times 10^{-8}}{1^3} = 180 \text{ N/C}$$

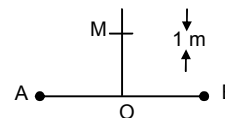

72. Let $-q$ & $-q$ are placed at A & C
 Where $2q$ on B So length of A = d
 So the dipole moment = $(q \times d) = P$
 So, Resultant dipole moment

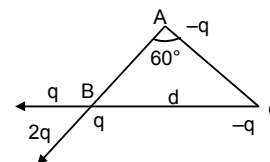

$$P = [(qd)^2 + (qd)^2 + 2qd \times qd \cos 60^\circ]^{1/2} = [3q^2d^2]^{1/2} = \sqrt{3} qd = \sqrt{3} P$$

73. (a) $P = 2qa$

(b) $E_1 \sin \theta = E_2 \sin \theta$ Electric field intensity
 $= E_1 \cos \theta + E_2 \cos \theta = 2 E_1 \cos \theta$

$$E_1 = \frac{Kqp}{a^2 + d^2} \text{ so } E = \frac{2KPQ}{a^2 + d^2} \frac{a}{(a^2 + d^2)^{1/2}} = \frac{2Kq \times a}{(a^2 + d^2)^{3/2}}$$

When $a \ll d$ $= \frac{2Kqa}{(d^2)^{3/2}} = \frac{PK}{d^3} = \frac{1}{4\pi\epsilon_0} \frac{P}{d^3}$

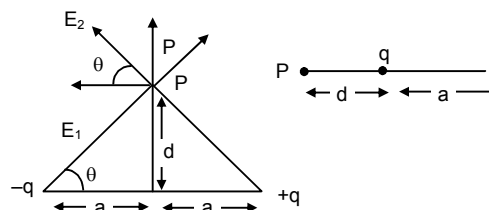

74. Consider the rod to be a simple pendulum.

For simple pendulum $T = 2\pi\sqrt{\ell/g}$ (ℓ = length, g = acceleration)

Now, force experienced by the charges

$$F = Eq \quad \text{Now, acceleration} = \frac{F}{m} = \frac{Eq}{m}$$

Hence length = a so, Time period = $2\pi\sqrt{\frac{a}{(Eq/m)}} = 2\pi\sqrt{\frac{ma}{Eq}}$

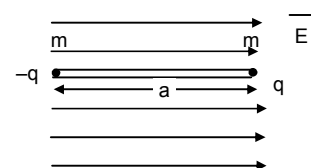

75. 64 grams of copper have 1 mole 6.4 grams of copper have 0.1 mole
 1 mole = No atoms 0.1 mole = (no \times 0.1) atoms
 $= 6 \times 10^{23} \times 0.1$ atoms = 6×10^{22} atoms
 1 atom contributes 1 electron 6×10^{22} atoms contributes 6×10^{22} electrons.



CHAPTER – 30 GAUSS'S LAW

1. Given : $\vec{E} = 3/5 E_0 \hat{i} + 4/5 E_0 \hat{j}$

$E_0 = 2.0 \times 10^3$ N/C The plane is parallel to yz-plane.

Hence only $3/5 E_0 \hat{i}$ passes perpendicular to the plane whereas $4/5 E_0 \hat{j}$ goes parallel. Area = 0.2m^2 (given)

$$\therefore \text{Flux} = \vec{E} \cdot \vec{A} = 3/5 \times 2 \times 10^3 \times 0.2 = 2.4 \times 10^2 \text{ Nm}^2/\text{c} = 240 \text{ Nm}^2/\text{c}$$

2. Given length of rod = edge of cube = ℓ

Portion of rod inside the cube = $\ell/2$

Total charge = Q.

Linear charge density = $\lambda = Q/\ell$ of rod.

We know: Flux \propto charge enclosed.

Charge enclosed in the rod inside the cube.

$$= \ell/2 \epsilon_0 \times Q/\ell = Q/2 \epsilon_0$$

3. As the electric field is uniform.

Considering a perpendicular plane to it, we find that it is an equipotential surface. Hence there is no net current flow on that surface. Thus, net charge in that region is zero.

4. Given: $E = \frac{E_0 \lambda}{\ell} \hat{i}$ $\ell = 2$ cm, $a = 1$ cm.

$E_0 = 5 \times 10^3$ N/C. From fig. We see that flux passes mainly through surface areas. ABDC & EFGH. As the AEFB & CHGD are parallel to the Flux. Again in ABDC $a = 0$; hence the Flux only passes through the surface are EFGH.

$$E = \frac{E_c \lambda}{\ell} \hat{i}$$

$$\text{Flux} = \frac{E_0 \lambda}{L} \times \text{Area} = \frac{5 \times 10^3 \times a}{\ell} \times a^2 = \frac{5 \times 10^3 \times a^3}{\ell} = \frac{5 \times 10^3 \times (0.01)^3}{2 \times 10^{-2}} = 2.5 \times 10^{-1}$$

$$\text{Flux} = \frac{q}{\epsilon_0} \text{ so, } q = \epsilon_0 \times \text{Flux}$$

$$= 8.85 \times 10^{-12} \times 2.5 \times 10^{-1} = 2.2125 \times 10^{-12} \text{ c}$$

5. According to Gauss's Law Flux = $\frac{q}{\epsilon_0}$

Since the charge is placed at the centre of the cube. Hence the flux passing through the

$$\text{six surfaces} = \frac{Q}{6\epsilon_0} \times 6 = \frac{Q}{\epsilon_0}$$

6. Given – A charge is placed o a plain surface with area = a^2 , about $a/2$ from its centre.

Assumption : let us assume that the given plain forms a surface of an imaginary cube. Then the charge is found to be at the centre of the cube.

$$\text{Hence flux through the surface} = \frac{Q}{\epsilon_0} \times \frac{1}{6} = \frac{Q}{6\epsilon_0}$$

7. Given: Magnitude of the two charges placed = 10^{-7} c.

We know: from Gauss's law that the flux experienced by the sphere is only due to the internal charge and not by the external one.

$$\text{Now } \oint \vec{E} \cdot d\vec{s} = \frac{Q}{\epsilon_0} = \frac{10^{-7}}{8.85 \times 10^{-12}} = 1.1 \times 10^4 \text{ N-m}^2/\text{C}.$$

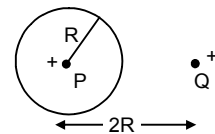
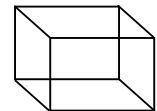
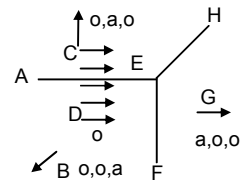
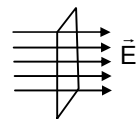
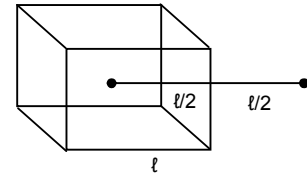
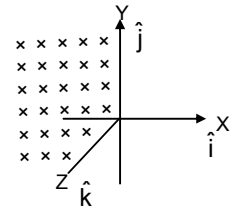

8. We know: For a spherical surface

$$\text{Flux} = \oint \vec{E} \cdot d\vec{s} = \frac{q}{\epsilon_0} \quad [\text{by Gauss law}]$$

$$\text{Hence for a hemisphere} = \text{total surface area} = \frac{q}{\epsilon_0} \times \frac{1}{2} = \frac{q}{2\epsilon_0}$$

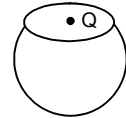

9. Given: Volume charge density = $2.0 \times 10^{-4} \text{ C/m}^3$

In order to find the electric field at a point $4 \text{ cm} = 4 \times 10^{-2} \text{ m}$ from the centre let us assume a concentric spherical surface inside the sphere.

$$\text{Now, } \oint \vec{E} \cdot d\vec{s} = \frac{q}{\epsilon_0}$$

$$\text{But } \sigma = \frac{q}{4/3\pi R^3} \quad \text{so, } q = \sigma \times 4/3 \pi R^3$$

$$\begin{aligned} \text{Hence} &= \frac{\sigma \times 4/3 \times 22/7 \times (4 \times 10^{-2})^3}{\epsilon_0} \times \frac{1}{4 \times 22/7 \times (4 \times 10^{-2})^2} \\ &= 2.0 \times 10^{-4} \times \frac{1}{3} \times 4 \times 10^{-2} \times \frac{1}{8.85 \times 10^{-12}} = 3.0 \times 10^5 \text{ N/C} \end{aligned}$$

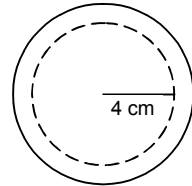

10. Charge present in a gold nucleus = $79 \times 1.6 \times 10^{-19} \text{ C}$

Since the surface encloses all the charges we have:

$$(a) \oint \vec{E} \cdot d\vec{s} = \frac{q}{\epsilon_0} = \frac{79 \times 1.6 \times 10^{-19}}{8.85 \times 10^{-12}}$$

$$\begin{aligned} E &= \frac{q}{\epsilon_0 ds} = \frac{79 \times 1.6 \times 10^{-19}}{8.85 \times 10^{-12}} \times \frac{1}{4 \times 3.14 \times (7 \times 10^{-15})^2} \quad [\because \text{area} = 4\pi r^2] \\ &= 2.3195131 \times 10^{21} \text{ N/C} \end{aligned}$$

(b) For the middle part of the radius. Now here $r = 7/2 \times 10^{-15} \text{ m}$

$$\text{Volume} = 4/3 \pi r^3 = \frac{48}{3} \times \frac{22}{7} \times \frac{343}{8} \times 10^{-45}$$

Charge enclosed = $\zeta \times \text{volume}$ [ζ : volume charge density]

$$\text{But } \zeta = \frac{\text{Net charge}}{\text{Net volume}} = \frac{7.9 \times 1.6 \times 10^{-19} \text{ C}}{\left(\frac{4}{3}\right) \times \pi \times 343 \times 10^{-45}}$$

$$\text{Net charged enclosed} = \frac{7.9 \times 1.6 \times 10^{-19}}{\left(\frac{4}{3}\right) \times \pi \times 343 \times 10^{-45}} \times \frac{4}{3} \pi \times \frac{343}{8} \times 10^{-45} = \frac{7.9 \times 1.6 \times 10^{-19}}{8}$$

$$\oint \vec{E} \cdot d\vec{s} = \frac{q \text{ enclosed}}{\epsilon_0}$$

$$\Rightarrow E = \frac{7.9 \times 1.6 \times 10^{-19}}{8 \times \epsilon_0 \times S} = \frac{7.9 \times 1.6 \times 10^{-19}}{8 \times 8.85 \times 10^{-12} \times 4\pi \times \frac{49}{4} \times 10^{-30}} = 1.159 \times 10^{21} \text{ N/C}$$

11. Now, Volume charge density = $\frac{Q}{\frac{4}{3} \times \pi \times (r_2^3 - r_1^3)}$

$$\therefore \zeta = \frac{3Q}{4\pi(r_2^3 - r_1^3)}$$

$$\text{Again volume of sphere having radius } x = \frac{4}{3} \pi x^3$$

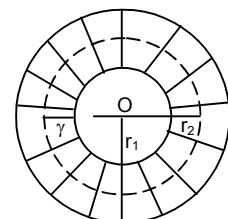

Now charge enclosed by the sphere having radius

$$\chi = \left(\frac{4}{3} \pi \chi^3 - \frac{4}{3} \pi r_1^3 \right) \times \frac{Q}{\frac{4}{3} \pi r_2^3 - \frac{4}{3} \pi r_1^3} = Q \left(\frac{\chi^3 - r_1^3}{r_2^3 - r_1^3} \right)$$

Applying Gauss's law $- E \times 4\pi\chi^2 = \frac{q \text{ enclosed}}{\epsilon_0}$

$$\Rightarrow E = \frac{Q}{\epsilon_0} \left(\frac{\chi^3 - r_1^3}{r_2^3 - r_1^3} \right) \times \frac{1}{4\pi\chi^2} = \frac{Q}{4\pi\epsilon_0\chi^2} \left(\frac{\chi^3 - r_1^3}{r_2^3 - r_1^3} \right)$$

12. Given: The sphere is uncharged metallic sphere.

Due to induction the charge induced at the inner surface = $-Q$, and that outer surface = $+Q$.

(a) Hence the surface charge density at inner and outer surfaces = $\frac{\text{charge}}{\text{total surface area}}$

$$= -\frac{Q}{4\pi a^2} \text{ and } \frac{Q}{4\pi a^2} \text{ respectively.}$$

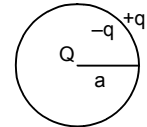

(b) Again if another charge 'q' is added to the surface. We have inner surface charge density = $-\frac{Q}{4\pi a^2}$,

because the added charge does not affect it.

On the other hand the external surface charge density = $Q + \frac{q}{4\pi a^2}$ as the 'q' gets added up.

(c) For electric field let us assume an imaginary surface area inside the sphere at a distance 'x' from centre. This is same in both the cases as the 'q' is ineffective.

$$\text{Now, } \oint E \cdot ds = \frac{Q}{\epsilon_0} \text{ So, } E = \frac{Q}{\epsilon_0} \times \frac{1}{4\pi x^2} = \frac{Q}{4\pi\epsilon_0 x^2}$$

13. (a) Let the three orbits be considered as three concentric spheres A, B & C.

Now, Charge of 'A' = $4 \times 1.6 \times 10^{-16} \text{ C}$

Charge of 'B' = $2 \times 1.6 \times 10^{-16} \text{ C}$

Charge of 'C' = $2 \times 1.6 \times 10^{-16} \text{ C}$

As the point 'P' is just inside 1s, so its distance from centre = $1.3 \times 10^{-11} \text{ m}$

$$\text{Electric field} = \frac{Q}{4\pi\epsilon_0 x^2} = \frac{4 \times 1.6 \times 10^{-19}}{4 \times 3.14 \times 8.85 \times 10^{-12} \times (1.3 \times 10^{-11})^2} = 3.4 \times 10^{13} \text{ N/C}$$

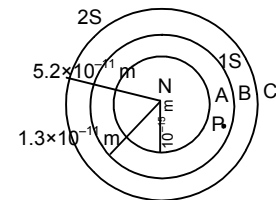

(b) For a point just inside the 2 s cloud

Total charge enclosed = $4 \times 1.6 \times 10^{-19} - 2 \times 1.6 \times 10^{-19} = 2 \times 1.6 \times 10^{-19}$

Hence, Electric field,

$$\vec{E} = \frac{2 \times 1.6 \times 10^{-19}}{4 \times 3.14 \times 8.85 \times 10^{-12} \times (5.2 \times 10^{-11})^2} = 1.065 \times 10^{12} \text{ N/C} \approx 1.1 \times 10^{12} \text{ N/C}$$

14. Drawing an electric field around the line charge we find a cylinder of radius $4 \times 10^{-2} \text{ m}$.

Given: λ = linear charge density

Let the length be $\ell = 2 \times 10^{-6} \text{ c/m}$

$$\text{We know } \oint E \cdot dl = \frac{Q}{\epsilon_0} = \frac{\lambda \ell}{\epsilon_0}$$

$$\Rightarrow E \times 2\pi r \ell = \frac{\lambda \ell}{\epsilon_0} \Rightarrow E = \frac{\lambda}{\epsilon_0 \times 2\pi r}$$

For, $r = 2 \times 10^{-2} \text{ m}$ & $\lambda = 2 \times 10^{-6} \text{ c/m}$

$$\Rightarrow E = \frac{2 \times 10^{-6}}{8.85 \times 10^{-12} \times 2 \times 3.14 \times 2 \times 10^{-2}} = 8.99 \times 10^5 \text{ N/C} \approx 9 \times 10^5 \text{ N/C}$$

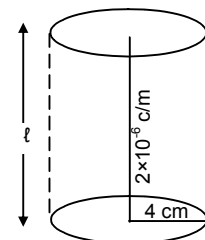

15. Given :

$$\lambda = 2 \times 10^{-6} \text{ C/m}$$

For the previous problem.

$$E = \frac{\lambda}{\epsilon_0 2\pi r} \text{ for a cylindrical electric field.}$$

Now, For experienced by the electron due to the electric field in wire = centripetal force.

$$Eq = mv^2 \quad \left[\begin{array}{l} \text{we know, } m_e = 9.1 \times 10^{-31} \text{ kg,} \\ v_e = ?, r = \text{assumed radius} \end{array} \right]$$

$$\Rightarrow \frac{1}{2} Eq = \frac{1}{2} \frac{mv^2}{r}$$

$$\Rightarrow KE = 1/2 \times E \times q \times r = \frac{1}{2} \times \frac{\lambda}{\epsilon_0 2\pi r} \times 1.6 \times 10^{-19} = 2.88 \times 10^{-17} \text{ J.}$$

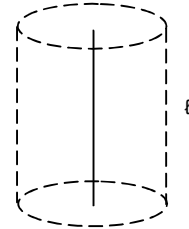

16. Given: Volume charge density = ζ

Let the height of cylinder be h.

$$\therefore \text{Charge } Q \text{ at } P = \zeta \times 4\pi r^2 \times h$$

$$\text{For electric field } \oint E \cdot ds = \frac{Q}{\epsilon_0}$$

$$E = \frac{Q}{\epsilon_0 \times ds} = \frac{\zeta \times 4\pi r^2 \times h}{\epsilon_0 \times 2 \times \pi \times r \times h} = \frac{2\zeta r}{\epsilon_0}$$

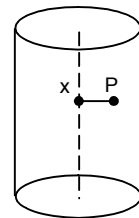

17. $\oint E \cdot dA = \frac{Q}{\epsilon_0}$

Let the area be A.

Uniform charge distribution density is ζ

$$Q = \zeta A$$

$$E = \frac{Q}{\epsilon_0} \times dA = \frac{\zeta \times a \times \chi}{\epsilon_0 \times A} = \frac{\zeta \chi}{\epsilon_0}$$

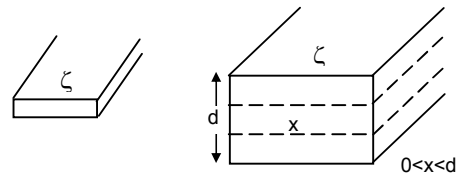

18. $Q = -2.0 \times 10^{-6} \text{ C}$ Surface charge density = $4 \times 10^{-6} \text{ C/m}^2$

$$\text{We know } \vec{E} \text{ due to a charge conducting sheet} = \frac{\sigma}{2\epsilon_0}$$

Again Force of attraction between particle & plate

$$= Eq = \frac{\sigma}{2\epsilon_0} \times q = \frac{4 \times 10^{-6} \times 2 \times 10^{-6}}{2 \times 8 \times 10^{-12}} = 0.452 \text{ N}$$

19. Ball mass = 10g

$$\text{Charge} = 4 \times 10^{-6} \text{ C}$$

Thread length = 10 cm

Now from the fig, $T \cos \theta = mg$

$T \sin \theta = \text{electric force}$

$$\text{Electric force} = \frac{\sigma q}{2\epsilon_0} \quad (\sigma \text{ surface charge density})$$

$$T \sin \theta = \frac{\sigma q}{2\epsilon_0}, \quad T \cos \theta = mg$$

$$\tan \theta = \frac{\sigma q}{2mg\epsilon_0}$$

$$\sigma = \frac{2mg\epsilon_0 \tan \theta}{q} = \frac{2 \times 8.85 \times 10^{-12} \times 10 \times 10^{-3} \times 9.8 \times 1.732}{4 \times 10^{-6}} = 7.5 \times 10^{-7} \text{ C/m}^2$$

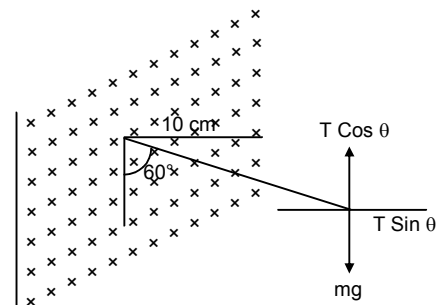

20. (a) Tension in the string in Equilibrium

$$T \cos 60^\circ = mg$$

$$\Rightarrow T = \frac{mg}{\cos 60^\circ} = \frac{10 \times 10^{-3} \times 10}{1/2} = 10^{-1} \times 2 = 0.20 \text{ N}$$

(b) Straingtening the same figure.

Now the resultant for 'R'

Induces the acceleration in the pendulum.

$$T = 2 \times \pi \sqrt{\frac{\ell}{g}} = 2\pi \sqrt{\frac{\ell}{\left[g^2 + \left(\frac{\sigma q}{2\epsilon_0 m} \right)^2 \right]^{1/2}}} = 2\pi \sqrt{\frac{\ell}{\left[100 + \left(0.2 \times \frac{\sqrt{3}}{2 \times 10^{-2}} \right)^2 \right]^{1/2}}}$$

$$= 2\pi \sqrt{\frac{\ell}{(100 + 300)^{1/2}}} = 2\pi \sqrt{\frac{\ell}{20}} = 2 \times 3.1416 \times \sqrt{\frac{10 \times 10^{-2}}{20}} = 0.45 \text{ sec.}$$

21. $s = 2\text{cm} = 2 \times 10^{-2}\text{m}$, $u = 0$, $a = ?$ $t = 2\mu\text{s} = 2 \times 10^{-6}\text{s}$

Acceleration of the electron, $s = (1/2) at^2$

$$2 \times 10^{-2} = (1/2) \times a \times (2 \times 10^{-6})^2 \Rightarrow a = \frac{2 \times 2 \times 10^{-2}}{4 \times 10^{-12}} \Rightarrow a = 10^{10} \text{ m/s}^2$$

The electric field due to charge plate = $\frac{\sigma}{\epsilon_0}$

Now, electric force = $\frac{\sigma}{\epsilon_0} \times q$ = acceleration = $\frac{\sigma}{\epsilon_0} \times \frac{q}{m_e}$

$$\text{Now } \frac{\sigma}{\epsilon_0} \times \frac{q}{m_e} = 10^{10}$$

$$\Rightarrow \sigma = \frac{10^{10} \times \epsilon_0 \times m_e}{q} = \frac{10^{10} \times 8.85 \times 10^{-12} \times 9.1 \times 10^{-31}}{1.6 \times 10^{-19}}$$

$$= 50.334 \times 10^{-14} = 0.50334 \times 10^{-12} \text{ C/m}^2$$

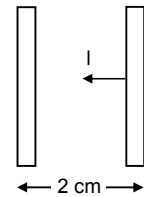

22. Given: Surface density = σ

(a) & (c) For any point to the left & right of the dual plater, the electric field is zero.

As there are no electric flux outside the system.

(b) For a test charge put in the middle.

It experiences a fore $\frac{\sigma q}{2\epsilon_0}$ towards the (-ve) plate.

Hence net electric field $\frac{1}{q} \left(\frac{\sigma q}{2\epsilon_0} + \frac{\sigma q}{2\epsilon_0} \right) = \frac{\sigma}{\epsilon_0}$

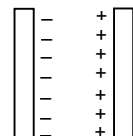
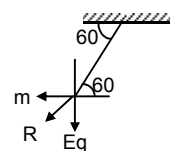
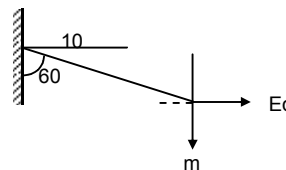

23. (a) For the surface charge density of a single plate.

Let the surface charge density at both sides be σ_1 & σ_2

$$\sigma_1 \sigma_2 = \frac{\sigma_1}{2\epsilon_0} \& \frac{\sigma_2}{2\epsilon_0}$$

Due to a net balanced electric field on the plate $\frac{\sigma_1}{2\epsilon_0} \& \frac{\sigma_2}{2\epsilon_0}$

$$\therefore \sigma_1 = \sigma_2 \text{ So, } q_1 = q_2 = Q/2$$

$$\therefore \text{Net surface charge density} = Q/2A$$

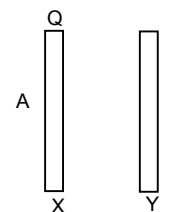

(b) Electric field to the left of the plates = $\frac{\sigma}{\epsilon_0}$

Since $\sigma = Q/2A$ Hence Electricfield = $Q/2A\epsilon_0$

This must be directed toward left as 'X' is the charged plate.

(c) & (d) Here in both the cases the charged plate 'X' acts as the only source of electric field, with (+ve) in the inner side and 'Y' attracts towards it with (-ve) he in

its inner side. So for the middle portion $E = \frac{Q}{2A\epsilon_0}$ towards right.

(d) Similarly for extreme right the outside of the 'Y' plate acts as positive and hence it repels to the right with $E = \frac{Q}{2A\epsilon_0}$

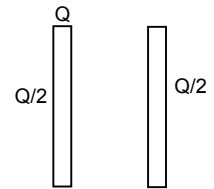

24. Consider the Gaussian surface the induced charge be as shown in figure.

The net field at P due to all the charges is Zero.

$$\therefore -2Q + 9/2A \epsilon_0 (\text{left}) + 9/2A \epsilon_0 (\text{left}) + 9/2A \epsilon_0 (\text{right}) + Q - 9/2A \epsilon_0 (\text{right}) = 0$$

$$\Rightarrow -2Q + 9 - Q + 9 = 0 \Rightarrow 9 = 3/2 Q$$

\therefore charge on the right side of right most plate

$$= -2Q + 9 = -2Q + 3/2 Q = -Q/2$$

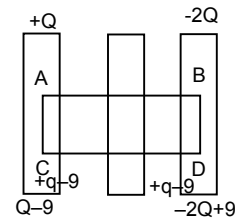

♣ ♣ ♣ ♣ ♣

CHAPTER – 31 CAPACITOR

1. Given that

$$\text{Number of electron} = 1 \times 10^{12}$$

$$\text{Net charge } Q = 1 \times 10^{12} \times 1.6 \times 10^{-19} = 1.6 \times 10^{-7} \text{ C}$$

∴ The net potential difference = 10 V.

$$\therefore \text{Capacitance} - C = \frac{q}{v} = \frac{1.6 \times 10^{-7}}{10} = 1.6 \times 10^{-8} \text{ F.}$$

2. $A = \pi r^2 = 25 \pi \text{ cm}^2$

$$d = 0.1 \text{ cm}$$

$$C = \frac{\epsilon_0 A}{d} = \frac{8.854 \times 10^{-12} \times 25 \times 3.14}{0.1} = 6.95 \times 10^{-5} \mu\text{F.}$$

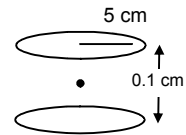

3. Let the radius of the disc = R

$$\therefore \text{Area} = \pi R^2$$

$$C = 1 \text{ f}$$

$$D = 1 \text{ mm} = 10^{-3} \text{ m}$$

$$\therefore C = \frac{\epsilon_0 A}{d}$$

$$\Rightarrow 1 = \frac{8.85 \times 10^{-12} \times \pi r^2}{10^{-3}} \Rightarrow r^2 = \frac{10^{-3} \times 10^{12}}{8.85 \times \pi} = \frac{10^9}{27.784} = 5998.5 \text{ m} = 6 \text{ Km}$$

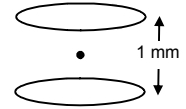

4. $A = 25 \text{ cm}^2 = 2.5 \times 10^{-3} \text{ cm}^2$

$$d = 1 \text{ mm} = 0.01 \text{ m}$$

$$V = 6 \text{ V} \quad Q = ?$$

$$C = \frac{\epsilon_0 A}{d} = \frac{8.854 \times 10^{-12} \times 2.5 \times 10^{-3}}{0.01}$$

$$Q = CV = \frac{8.854 \times 10^{-12} \times 2.5 \times 10^{-3}}{0.01} \times 6 = 1.32810 \times 10^{-10} \text{ C}$$

$$W = Q \times V = 1.32810 \times 10^{-10} \times 6 = 8 \times 10^{-10} \text{ J.}$$

5. Plate area $A = 25 \text{ cm}^2 = 2.5 \times 10^{-3} \text{ m}^2$

$$\text{Separation } d = 2 \text{ mm} = 2 \times 10^{-3} \text{ m}$$

$$\text{Potential } v = 12 \text{ v}$$

$$(a) \text{ We know } C = \frac{\epsilon_0 A}{d} = \frac{8.85 \times 10^{-12} \times 2.5 \times 10^{-3}}{2 \times 10^{-3}} = 11.06 \times 10^{-12} \text{ F}$$

$$C = \frac{q}{v} \Rightarrow 11.06 \times 10^{-12} = \frac{q}{12}$$

$$\Rightarrow q_1 = 1.32 \times 10^{-10} \text{ C.}$$

(b) Then d = decreased to 1 mm

$$\therefore d = 1 \text{ mm} = 1 \times 10^{-3} \text{ m}$$

$$C = \frac{\epsilon_0 A}{d} = \frac{q}{v} = \frac{8.85 \times 10^{-12} \times 2.5 \times 10^{-3}}{1 \times 10^{-3}} = \frac{2}{12}$$

$$\Rightarrow q_2 = 8.85 \times 2.5 \times 12 \times 10^{-12} = 2.65 \times 10^{-10} \text{ C.}$$

$$\therefore \text{The extra charge given to plate} = (2.65 - 1.32) \times 10^{-10} = 1.33 \times 10^{-10} \text{ C.}$$

6. $C_1 = 2 \mu\text{F}, \quad C_2 = 4 \mu\text{F},$

$$C_3 = 6 \mu\text{F} \quad V = 12 \text{ V}$$

$$Cq = C_1 + C_2 + C_3 = 2 + 4 + 6 = 12 \mu\text{F} = 12 \times 10^{-6} \text{ F}$$

$$q_1 = 12 \times 2 = 24 \mu\text{C}, \quad q_2 = 12 \times 4 = 48 \mu\text{C}, \quad q_3 = 12 \times 6 = 72 \mu\text{C}$$

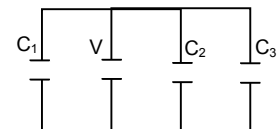
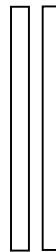
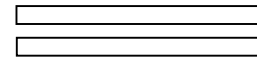

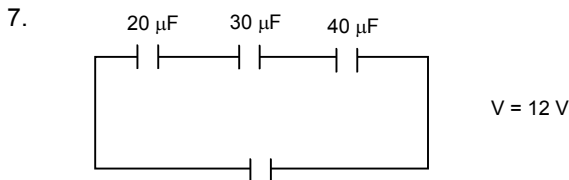

∴ The equivalent capacity.

$$C = \frac{C_1 C_2 C_3}{C_2 C_3 + C_1 C_3 + C_1 C_2} = \frac{20 \times 30 \times 40}{30 \times 40 + 20 \times 40 + 20 \times 30} = \frac{24000}{2600} = 9.23 \mu\text{F}$$

(a) Let Equivalent charge at the capacitor = q

$$C = \frac{q}{V} \Rightarrow q = C \times V = 9.23 \times 12 = 110 \mu\text{C on each.}$$

As this is a series combination, the charge on each capacitor is same as the equivalent charge which is $110 \mu\text{C}$.

(b) Let the work done by the battery = W

$$\therefore V = \frac{W}{q} \Rightarrow W = Vq = 110 \times 12 \times 10^{-6} = 1.33 \times 10^{-3} \text{ J.}$$

8. $C_1 = 8 \mu\text{F}$, $C_2 = 4 \mu\text{F}$, $C_3 = 4 \mu\text{F}$

$$C_{eq} = \frac{(C_2 + C_3) \times C_1}{C_1 + C_2 + C_3}$$

$$= \frac{8 \times 8}{16} = 4 \mu\text{F}$$

Since B & C are parallel & are in series with A

So, $q_1 = 8 \times 6 = 48 \mu\text{C}$

$q_2 = 4 \times 6 = 24 \mu\text{C}$

$q_3 = 4 \times 6 = 24 \mu\text{C}$

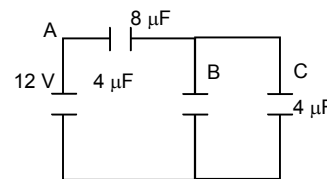

9. (a)

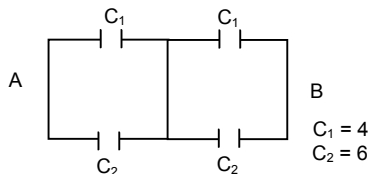

∴ C_1, C_1 are series & C_2, C_2 are series as the V is same at p & q . So no current pass through p & q .

$$\frac{1}{C} = \frac{1}{C_1} = \frac{1}{C_2} \Rightarrow \frac{1}{C} = \frac{1+1}{C_1 C_2}$$

$$C_p = \frac{C_1}{2} = \frac{4}{2} = 2 \mu\text{F}$$

$$\text{And } C_q = \frac{C_2}{2} = \frac{6}{2} = 3 \mu\text{F}$$

∴ $C = C_p + C_q = 2 + 3 = 5 \mu\text{F}$

(b) $C_1 = 4 \mu\text{F}$, $C_2 = 6 \mu\text{F}$,

In case of p & q , $q = 0$

$$\therefore C_p = \frac{C_1}{2} = \frac{4}{2} = 2 \mu\text{F}$$

$$C_q = \frac{C_2}{2} = \frac{6}{2} = 3 \mu\text{F}$$

& $C' = 2 + 3 = 5 \mu\text{F}$

C & $C' = 5 \mu\text{F}$

∴ The equation of capacitor $C = C' + C'' = 5 + 5 = 10 \mu\text{F}$

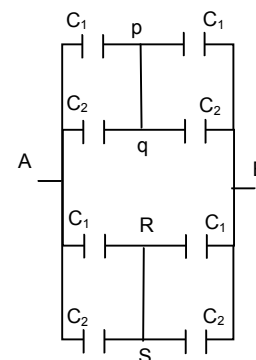

10. $V = 10 \text{ v}$
 $C_{eq} = C_1 + C_2$ [\therefore They are parallel]
 $= 5 + 6 = 11 \mu\text{F}$
 $q = CV = 11 \times 10 = 110 \mu\text{C}$

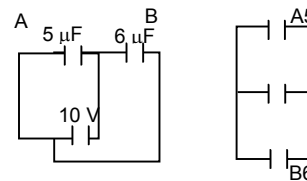

11. The capacitance of the outer sphere = $2.2 \mu\text{F}$
 $C = 2.2 \mu\text{F}$
 Potential, $V = 10 \text{ v}$
 Let the charge given to individual cylinder = q .

$$C = \frac{q}{V}$$

$$\Rightarrow q = CV = 2.2 \times 10 = 22 \mu\text{C}$$

\therefore The total charge given to the inner cylinder = $22 + 22 = 44 \mu\text{C}$

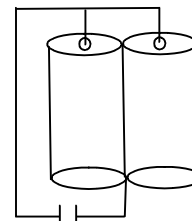

12. $C = \frac{q}{V}$, Now $V = \frac{Kq}{R}$

$$\text{So, } C_1 = \frac{q}{(Kq/R_1)} = \frac{R_1}{K} = 4 \pi \epsilon_0 R_1$$

Similarly $C_2 = 4 \pi \epsilon_0 R_2$

The combination is necessarily parallel.

Hence $C_{eq} = 4 \pi \epsilon_0 R_1 + 4 \pi \epsilon_0 R_2 = 4 \pi \epsilon_0 (R_1 + R_2)$

- 13.

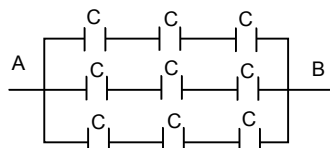

$$\therefore C = 2 \mu\text{F}$$

\therefore In this system the capacitance are arranged in series. Then the capacitance is parallel to each other.

(a) \therefore The equation of capacitance in one row

$$C = \frac{C}{3}$$

(b) and three capacitance of capacity $\frac{C}{3}$ are connected in parallel

\therefore The equation of capacitance

$$C = \frac{C}{3} + \frac{C}{3} + \frac{C}{3} = C = 2 \mu\text{F}$$

As the volt capacitance on each row are same and the individual is

$$= \frac{\text{Total}}{\text{No. of capacitance}} = \frac{60}{3} = 20 \text{ V}$$

14. Let there are 'x' no of capacitors in series ie in a row

$$\text{So, } x \times 50 = 200$$

$$\Rightarrow x = 4 \text{ capacitors.}$$

$$\text{Effective capacitance in a row} = \frac{10}{4}$$

Now, let there are 'y' such rows,

$$\text{So, } \frac{10}{4} \times y = 10$$

$$\Rightarrow y = 4 \text{ capacitor.}$$

So, the combinations of four rows each of 4 capacitors.

15.

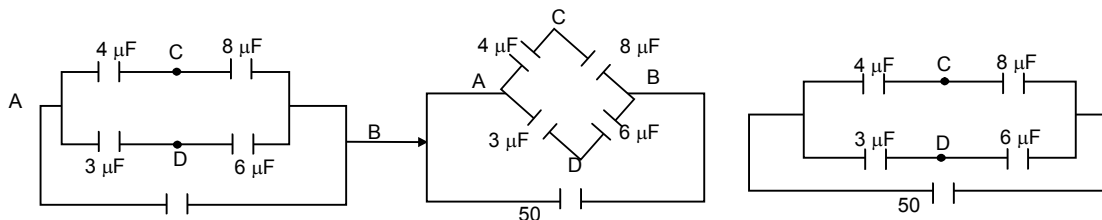

(a) Capacitor = $\frac{4 \times 8}{4 + 8} = \frac{8}{3} \mu$

and $\frac{6 \times 3}{6 + 3} = 2 \mu F$

(i) The charge on the capacitance $\frac{8}{3} \mu F$

$\therefore Q = \frac{8}{3} \times 50 = \frac{400}{3}$

\therefore The potential at $4 \mu F = \frac{400}{3 \times 4} = \frac{100}{3}$

at $8 \mu F = \frac{400}{3 \times 8} = \frac{100}{6}$

The Potential difference = $\frac{100}{3} - \frac{100}{6} = \frac{50}{3} \mu V$

(ii) Hence the effective charge at $2 \mu F = 50 \times 2 = 100 \mu F$

\therefore Potential at $3 \mu F = \frac{100}{3}$; Potential at $6 \mu F = \frac{100}{6}$

\therefore Difference = $\frac{100}{3} - \frac{100}{6} = \frac{50}{3} \mu V$

\therefore The potential at C & D is $\frac{50}{3} \mu V$

(b) $\therefore \frac{P}{q} = \frac{R}{S} = \frac{1}{2} = \frac{1}{2}$ = It is balanced. So from it is cleared that the wheat star bridge balanced. So

the potential at the point C & D are same. So no current flow through the point C & D. So if we connect another capacitor at the point C & D the charge on the capacitor is zero.

16. Ceq between a & b

= $\frac{C_1 C_2}{C_1 + C_2} + C_3 + \frac{C_1 C_2}{C_1 + C_2}$

= $C_3 + \frac{2C_1 C_2}{C_1 + C_2}$ (\therefore The three are parallel)

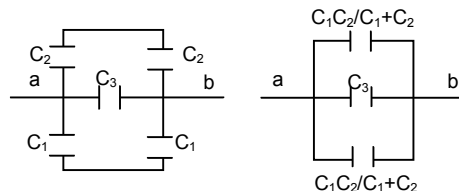

17. In the figure the three capacitors are arranged in parallel.

All have same surface area = $a = \frac{A}{3}$

First capacitance $C_1 = \frac{\epsilon_0 A}{3d}$

2nd capacitance $C_2 = \frac{\epsilon_0 A}{3(b+d)}$

3rd capacitance $C_3 = \frac{\epsilon_0 A}{3(2b+d)}$

Ceq = $C_1 + C_2 + C_3$

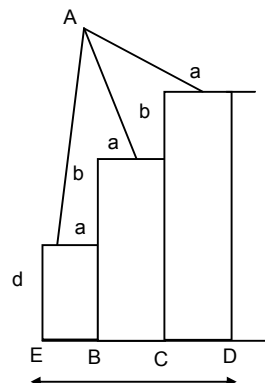

$$= \frac{\epsilon_0 A}{3d} + \frac{\epsilon_0 A}{3(b+d)} + \frac{\epsilon_0 A}{3(2b+d)} = \frac{\epsilon_0 A}{3} \left(\frac{1}{d} + \frac{1}{b+d} + \frac{1}{2b+d} \right)$$

$$= \frac{\epsilon_0 A}{3} \left(\frac{(b+d)(2b+d) + (2b+d)d + (b+d)d}{d(b+d)(2b+d)} \right)$$

$$= \frac{\epsilon_0 A(3d^2 + 6bd + 2b^2)}{3d(b+d)(2b+d)}$$

18. (a) $C = \frac{2\epsilon_0 L}{\ln(R_2/R_1)} = \frac{e \times 3.14 \times 8.85 \times 10^{-2} \times 10^{-1}}{\ln 2}$ [ln2 = 0.6932]

= $80.17 \times 10^{-13} \Rightarrow 8 \text{ PF}$

(b) Same as R_2/R_1 will be same.

19. Given that

$C = 100 \text{ PF} = 100 \times 10^{-12} \text{ F}$

$C_{cq} = 20 \text{ PF} = 20 \times 10^{-12} \text{ F}$

$V = 24 \text{ V}$

$q = 24 \times 100 \times 10^{-12} = 24 \times 10^{-10}$

$q_2 = ?$

Let $q_1 =$ The new charge 100 PF $V_1 =$ The Voltage.

Let the new potential is V_1

After the flow of charge, potential is same in the two capacitor

$$V_1 = \frac{q_2}{C_2} = \frac{q_1}{C_1}$$

$$= \frac{q - q_1}{C_2} = \frac{q_1}{C_1}$$

$$= \frac{24 \times 10^{-10} - q_1}{24 \times 10^{-12}} = \frac{q_1}{100 \times 10^{-12}}$$

$$= 24 \times 10^{-10} - q_1 = \frac{q_1}{5}$$

$$= 6q_1 = 120 \times 10^{-10}$$

$$= q_1 = \frac{120}{6} \times 10^{-10} = 20 \times 10^{-10}$$

$$\therefore V_1 = \frac{q_1}{C_1} = \frac{20 \times 10^{-10}}{100 \times 10^{-12}} = 20 \text{ V}$$

20.

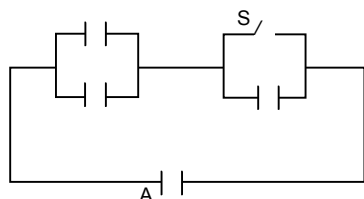

Initially when 's' is not connected,

$$C_{\text{eff}} = \frac{2C}{3} q = \frac{2C}{3} \times 50 = \frac{5}{2} \times 10^{-4} = 1.66 \times 10^{-4} \text{ C}$$

After the switch is made on,

Then $C_{\text{eff}} = 2C = 10^{-5}$

$Q = 10^{-5} \times 50 = 5 \times 10^{-4}$

Now, the initial charge will remain stored in the stored in the short capacitor

Hence net charge flowing

$$= 5 \times 10^{-4} - 1.66 \times 10^{-4} = 3.3 \times 10^{-4} \text{ C.}$$

21.

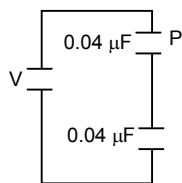

Given that mass of particle $m = 10 \text{ mg}$

Charge $1 = - 0.01 \text{ } \mu\text{C}$

$A = 100 \text{ cm}^2$ Let potential = V

The Equation capacitance $C = \frac{0.04}{2} = 0.02 \text{ } \mu\text{F}$

The particle may be in equilibrium, so that the wt. of the particle acting down ward, must be balanced by the electric force acting up ward.

$$\therefore qE = Mg$$

Electric force = $qE = q \frac{V}{d}$ where V – Potential, d – separation of both the plates.

$$= q \frac{VC}{\epsilon_0 A} \quad C = \frac{\epsilon_0 A}{d} \quad d = \frac{\epsilon_0 A}{C}$$

$$qE = mg$$

$$= \frac{QVC}{\epsilon_0 A} = mg$$

$$= \frac{0.01 \times 0.02 \times V}{8.85 \times 10^{-12} \times 100} = 0.1 \times 980$$

$$\Rightarrow V = \frac{0.1 \times 980 \times 8.85 \times 10^{-10}}{0.0002} = 0.00043 = 43 \text{ MV}$$

22. Let mass of electron = μ

Charge electron = e

We know, 'q'

For a charged particle to be projected in side to plates of a parallel plate capacitor with electric field E ,

$$y = \frac{1qE}{2m} \left(\frac{x}{\mu} \right)^2$$

where y – Vertical distance covered or

x – Horizontal distance covered

μ – Initial velocity

From the given data,

$$y = \frac{d_1}{2}, \quad E = \frac{V}{R} = \frac{qd_1}{\epsilon_0 a^2 \times d_1} = \frac{q}{\epsilon_0 a^2}, \quad x = a, \quad \mu = ?$$

For capacitor A –

$$V_1 = \frac{q}{C_1} = \frac{qd_1}{\epsilon_0 a^2} \text{ as } C_1 = \frac{\epsilon_0 a^2}{d_1}$$

Here q = chare on capacitor.

$$q = C \times V \text{ where } C = \text{Equivalent capacitance of the total arrangement} = \frac{\epsilon_0 a^2}{d_1 + d_2}$$

$$\text{So, } q = \frac{\epsilon_0 a^2}{d_1 + d_2} \times V$$

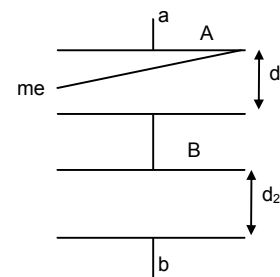

Hence $E = \frac{q}{\epsilon_0 a^2} = \frac{\epsilon_0 a^2 \times V}{(d_1 + d_2)\epsilon_0 a^2} = \frac{V}{(d_1 + d_2)}$

Substituting the data in the known equation, we get, $\frac{d_1}{2} = \frac{1}{2} \times \frac{e \times V}{(d_1 + d_2)m} \times \frac{a^2}{u^2}$

$\Rightarrow u^2 = \frac{Vea^2}{d_1 m (d_1 + d_2)} \Rightarrow u = \left(\frac{Vea^2}{d_1 m (d_1 + d_2)} \right)^{1/2}$

23. The acceleration of electron $a_e = \frac{q_e m_e}{M_e}$

The acceleration of proton = $\frac{q_p e}{M_p} = a_p$

The distance travelled by proton $X = \frac{1}{2} a_p t^2$... (1)

The distance travelled by electron ... (2)

From (1) and (2) $\Rightarrow 2 - X = \frac{1}{2} a_c t^2$ $x = \frac{1}{2} a_c t^2$

$\Rightarrow \frac{x}{2-x} = \frac{a_p}{a_c} = \frac{\left(\frac{q_p E}{M_p} \right)}{\left(\frac{q_c F}{M_c} \right)}$

$= \frac{x}{2-x} = \frac{M_c}{M_p} = \frac{9.1 \times 10^{-31}}{1.67 \times 10^{-27}} = \frac{9.1}{1.67} \times 10^{-4} = 5.449 \times 10^{-4}$

$\Rightarrow x = 10.898 \times 10^{-4} - 5.449 \times 10^{-4} x$

$\Rightarrow x = \frac{10.898 \times 10^{-4}}{1.0005449} = 0.001089226$

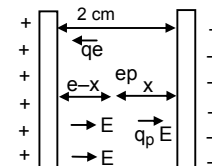

24. (a)

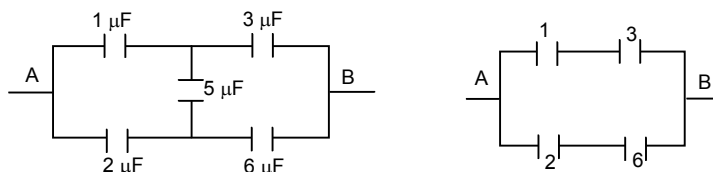

As the bridge is balanced there is no current through the 5 μF capacitor

So, it reduces to

similar in the case of (b) & (c)

as 'b' can also be written as.

$C_{eq} = \frac{1 \times 3}{1+3} + \frac{2 \times 6}{2+6} = \frac{3}{4} + \frac{12}{8} = \frac{6+12}{8} = 2.25 \mu F$

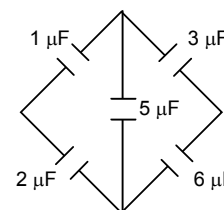

25. (a) By loop method application in the closed circuit ABCaDA

$-12 + \frac{2Q}{2\mu F} + \frac{Q_1}{2\mu F} + \frac{Q_1}{4\mu F} = 0$... (1)

In the close circuit ABCDA

$-12 + \frac{Q}{2\mu F} + \frac{Q+Q_1}{4\mu F} = 0$... (2)

From (1) and (2) $2Q + 3Q_1 = 48$... (3)

And $3Q - q_1 = 48$ and subtracting $Q = 4Q_1$, and substitution in equation

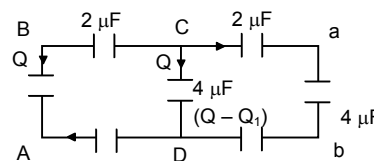

$$2Q + 3Q_1 = 48 \Rightarrow 8Q_1 + 3Q_1 = 48 \Rightarrow 11Q_1 = 48, q_1 = \frac{48}{11}$$

$$V_{ab} = \frac{Q_1}{4\mu F} = \frac{48}{11 \times 4} = \frac{12}{11} \text{ V}$$

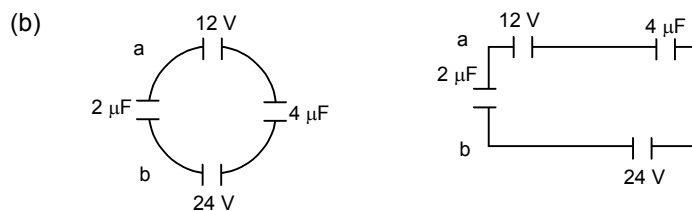

The potential = $24 - 12 = 12$

$$\text{Potential difference } V = \frac{(2 \times 0 + 12 \times 4)}{2 + 4} = \frac{48}{6} = 8 \text{ V}$$

∴ The $V_a - V_b = -8 \text{ V}$

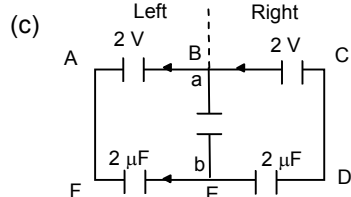

From the figure it is cleared that the left and right branch are symmetry and reversed, so the current go towards BE from BAFEB same as the current from EDCBE.

$$\therefore \text{The net charge } Q = 0 \quad \therefore V = \frac{Q}{C} = \frac{0}{C} = 0 \quad \therefore V_{ab} = 0$$

∴ The potential at K is zero.

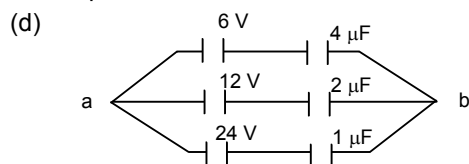

$$\text{The net potential} = \frac{\text{Net charge}}{\text{Net capacitance}} = \frac{24 + 24 + 24}{7} = \frac{72}{7} \approx 10.3 \text{ V}$$

$$\therefore V_a - V_b = -10.3 \text{ V}$$

26. (a)

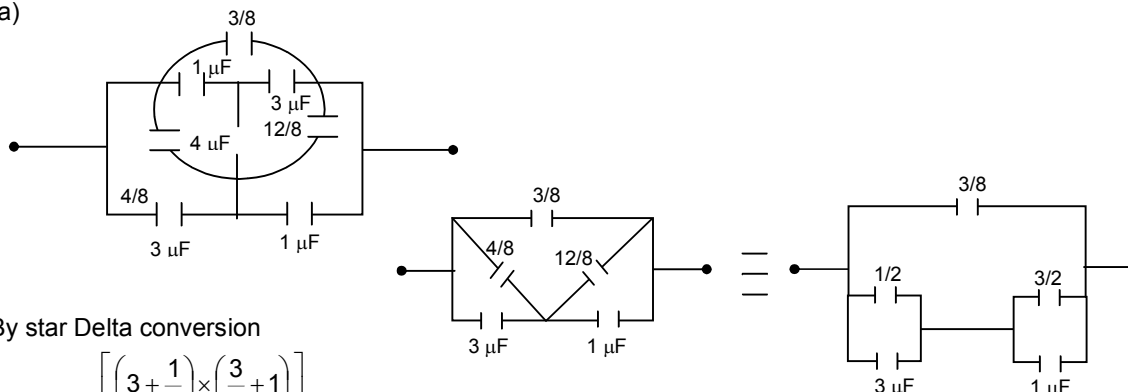

By star Delta conversion

$$C_{\text{eff}} = \frac{3}{8} + \left[\frac{\left(3 + \frac{1}{2}\right) \times \left(\frac{3}{2} + 1\right)}{\left(3 + \frac{1}{2}\right) + \left(\frac{3}{2} + 1\right)} \right] = \frac{3}{8} + \frac{35}{24} = \frac{9 + 35}{24} = \frac{44}{24} = \frac{11}{6} \mu F$$

(b)

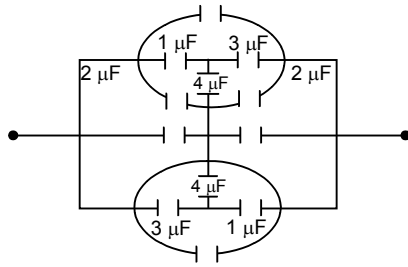

by star Delta convertor

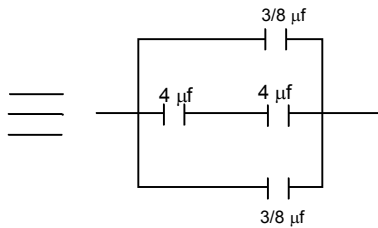
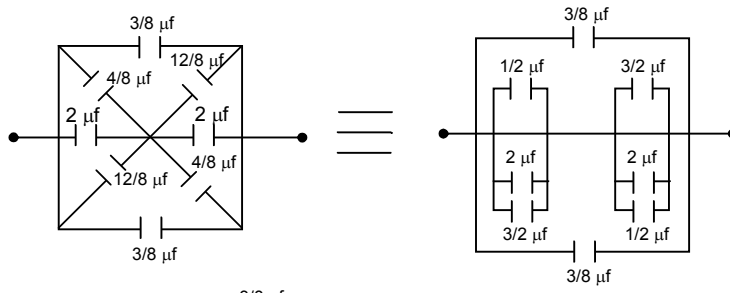

$$= \frac{3}{8} + \frac{16}{8} + \frac{3}{8} = \frac{11}{4} \mu\text{f}$$

(c)

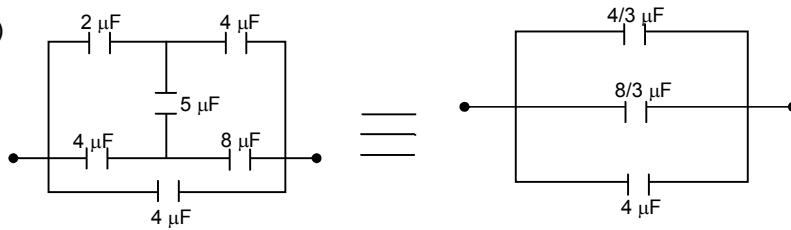

$$C_{\text{ef}} = \frac{4}{3} + \frac{8}{3} + 4 = 8 \mu\text{F}$$

(d)

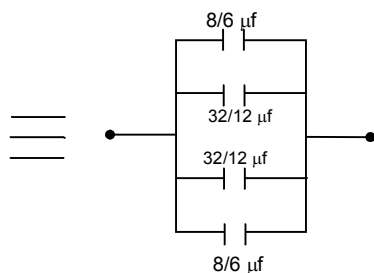
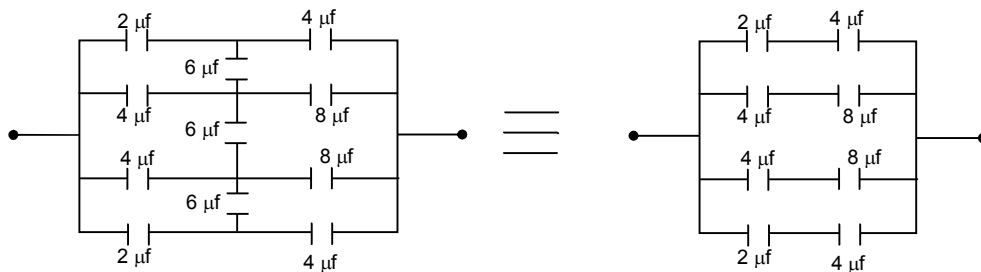

$$C_{\text{ef}} = \frac{3}{8} + \frac{32}{12} + \frac{32}{12} + \frac{8}{6} = \frac{16+32}{6} = 8 \mu\text{f}$$

27.

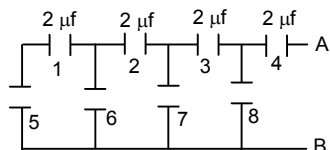

= C_5 and C_1 are in series

$$C_{eq} = \frac{2 \times 2}{2 + 2} = 1$$

This is parallel to $C_6 = 1 + 1 = 2$

Which is series to $C_2 = \frac{2 \times 2}{2 + 2} = 1$

Which is parallel to $C_7 = 1 + 1 = 2$

Which is series to $C_3 = \frac{2 \times 2}{2 + 2} = 1$

Which is parallel to $C_8 = 1 + 1 = 2$

This is series to $C_4 = \frac{2 \times 2}{2 + 2} = 1$

28.

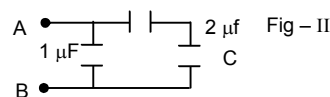
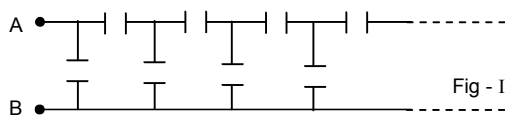

Let the equivalent capacitance be C . Since it is an infinite series. So, there will be negligible change if the arrangement is done as in Fig - II

$$C_{eq} = \frac{2 \times C}{2 + C} + 1 \Rightarrow C = \frac{2C + 2 + C}{2 + C}$$

$$\Rightarrow (2 + C) \times C = 3C + 2$$

$$\Rightarrow C^2 - C - 2 = 0$$

$$\Rightarrow (C - 2)(C + 1) = 0$$

$$C = -1 \text{ (Impossible)}$$

So, $C = 2 \mu\text{F}$

29.

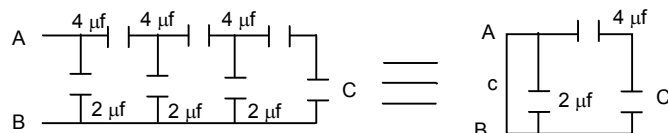

= C and $4 \mu\text{f}$ are in series

So, $C_1 = \frac{4 \times C}{4 + C}$

Then C_1 and $2 \mu\text{f}$ are parallel

$$C = C_1 + 2 \mu\text{f}$$

$$\Rightarrow \frac{4 \times C}{4 + C} + 2 \Rightarrow \frac{4C + 8 + 2C}{4 + C} = C$$

$$\Rightarrow 4C + 8 + 2C = 4C + C^2 = C^2 - 2C - 8 = 0$$

$$C = \frac{2 \pm \sqrt{4 + 4 \times 1 \times 8}}{2} = \frac{2 \pm \sqrt{36}}{2} = \frac{2 \pm 6}{2}$$

$$C = \frac{2 + 6}{2} = 4 \mu\text{f}$$

∴ The value of C is $4 \mu\text{f}$

30. $q_1 = +2.0 \times 10^{-8} \text{ C}$ $q_2 = -1.0 \times 10^{-8} \text{ C}$
 $C = 1.2 \times 10^{-3} \mu\text{F} = 1.2 \times 10^{-9} \text{ F}$

net $q = \frac{q_1 - q_2}{2} = \frac{3.0 \times 10^{-8}}{2}$

$V = \frac{q}{C} = \frac{3 \times 10^{-8}}{2} \times \frac{1}{1.2 \times 10^{-9}} = 12.5 \text{ V}$

31. ∴ Given that

Capacitance = $10 \mu\text{F}$

Charge = $20 \mu\text{C}$

∴ The effective charge = $\frac{20 - 0}{2} = 10 \mu\text{F}$

∴ $C = \frac{q}{V} \Rightarrow V = \frac{q}{C} = \frac{10}{10} = 1 \text{ V}$

32. $q_1 = 1 \mu\text{C} = 1 \times 10^{-6} \text{ C}$ $C = 0.1 \mu\text{F} = 1 \times 10^{-7} \text{ F}$
 $q_2 = 2 \mu\text{C} = 2 \times 10^{-6} \text{ C}$

net $q = \frac{q_1 - q_2}{2} = \frac{(1 - 2) \times 10^{-6}}{2} = -0.5 \times 10^{-6} \text{ C}$

Potential 'V' = $\frac{q}{C} = \frac{1 \times 10^{-7}}{-5 \times 10^{-7}} = -5 \text{ V}$

But potential can never be (-)ve. So, $V = 5 \text{ V}$

33. Here three capacitors are formed

And each of

$A = \frac{96}{\epsilon_0} \times 10^{-12} \text{ f.m.}$

$d = 4 \text{ mm} = 4 \times 10^{-3} \text{ m}$

∴ Capacitance of a capacitor

$C = \frac{\epsilon_0 A}{d} = \frac{\epsilon_0 \frac{96 \times 10^{-12}}{\epsilon_0}}{4 \times 10^{-3}} = 24 \times 10^{-9} \text{ F.}$

∴ As three capacitor are arranged is series

So, $C_{eq} = \frac{C}{3} = \frac{24 \times 10^{-9}}{3} = 8 \times 10^{-9}$

∴ The total charge to a capacitor = $8 \times 10^{-9} \times 10 = 8 \times 10^{-8} \text{ C}$

∴ The charge of a single Plate = $2 \times 8 \times 10^{-8} = 16 \times 10^{-8} = 0.16 \times 10^{-6} = 0.16 \mu\text{C.}$

34. (a) When charge of $1 \mu\text{C}$ is introduced to the B plate, we also get $0.5 \mu\text{C}$ charge on the upper surface of Plate 'A'.

(b) Given $C = 50 \mu\text{F} = 50 \times 10^{-9} \text{ F} = 5 \times 10^{-8} \text{ F}$

Now charge = $0.5 \times 10^{-6} \text{ C}$

$V = \frac{q}{C} = \frac{5 \times 10^{-7} \text{ C}}{5 \times 10^{-8} \text{ F}} = 10 \text{ V}$

35. Here given,

Capacitance of each capacitor, $C = 50 \mu\text{f} = 0.05 \mu\text{f}$

Charge $Q = 1 \mu\text{F}$ which is given to upper plate = $0.5 \mu\text{C}$ charge appear on outer and inner side of upper plate and $0.5 \mu\text{C}$ of charge also see on the middle.

(a) Charge of each plate = $0.5 \mu\text{C}$

Capacitance = $0.5 \mu\text{f}$

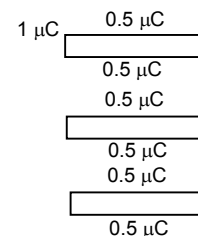
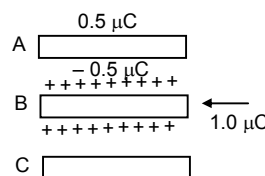
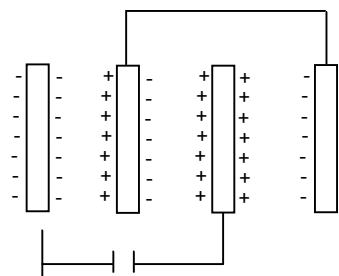
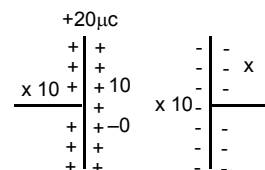

$$\therefore C = \frac{q}{V} \therefore V = \frac{q}{C} = \frac{0.5}{0.05} = 10 \text{ V}$$

(b) The charge on lower plate also = 0.5 μC
 Capacitance = 0.5 μF

$$\therefore C = \frac{q}{V} \Rightarrow V = \frac{q}{C} = \frac{0.5}{0.05} = 10 \text{ V}$$

\therefore The potential in 10 V

36. $C_1 = 20 \text{ PF} = 20 \times 10^{-12} \text{ F}$, $C_2 = 50 \text{ PF} = 50 \times 10^{-12} \text{ F}$

$$\text{Effective } C = \frac{C_1 C_2}{C_1 + C_2} = \frac{2 \times 10^{-11} \times 5 \times 10^{-11}}{2 \times 10^{-11} + 5 \times 10^{-11}} = 1.428 \times 10^{-11} \text{ F}$$

$$\text{Charge 'q' } = 1.428 \times 10^{-11} \times 6 = 8.568 \times 10^{-11} \text{ C}$$

$$V_1 = \frac{q}{C_1} = \frac{8.568 \times 10^{-11}}{2 \times 10^{-11}} = 4.284 \text{ V}$$

$$V_2 = \frac{q}{C_2} = \frac{8.568 \times 10^{-11}}{5 \times 10^{-11}} = 1.71 \text{ V}$$

Energy stored in each capacitor

$$E_1 = (1/2) C_1 V_1^2 = (1/2) \times 2 \times 10^{-11} \times (4.284)^2 = 18.35 \times 10^{-11} \approx 184 \text{ PJ}$$

$$E_2 = (1/2) C_2 V_2^2 = (1/2) \times 5 \times 10^{-11} \times (1.71)^2 = 7.35 \times 10^{-11} \approx 73.5 \text{ PJ}$$

37. $\therefore C_1 = 4 \mu\text{F}$, $C_2 = 6 \mu\text{F}$, $V = 20 \text{ V}$

$$\text{Eq. capacitor } C_{\text{eq}} = \frac{C_1 C_2}{C_1 + C_2} = \frac{4 \times 6}{4 + 6} = 2.4$$

\therefore The Eq Capacitance $C_{\text{eq}} = 2.5 \mu\text{F}$

\therefore The energy supplied by the battery to each plate

$$E = (1/2) CV^2 = (1/2) \times 2.4 \times 20^2 = 480 \mu\text{J}$$

\therefore The energy supplies by the battery to capacitor = $2 \times 480 = 960 \mu\text{J}$

38. $C = 10 \mu\text{F} = 10 \times 10^{-6} \text{ F}$

For a & d

$$q = 4 \times 10^{-4} \text{ C}$$

$$c = 10^{-5} \text{ F}$$

$$E = \frac{1}{2} \frac{q^2}{c} = \frac{1}{2} \frac{(4 \times 10^{-4})^2}{10^{-5}} = 8 \times 10^{-3} \text{ J} = 8 \text{ mJ}$$

For b & c

$$q = 4 \times 10^{-4} \text{ C}$$

$$C_{\text{eq}} = 2c = 2 \times 10^{-5} \text{ F}$$

$$V = \frac{4 \times 10^{-4}}{2 \times 10^{-5}} = 20 \text{ V}$$

$$E = (1/2) cV^2 = (1/2) \times 10^{-5} \times (20)^2 = 2 \times 10^{-3} \text{ J} = 2 \text{ mJ}$$

39. Stored energy of capacitor $C_1 = 4.0 \text{ J}$

$$= \frac{1}{2} \frac{q^2}{c^2} = 4.0 \text{ J}$$

When then connected, the charge shared

$$\frac{1}{2} \frac{q_1^2}{c^2} = \frac{1}{2} \frac{q_2^2}{c^2} \Rightarrow q_1 = q_2$$

So that the energy should divided.

\therefore The total energy stored in the two capacitors each is 2 J.

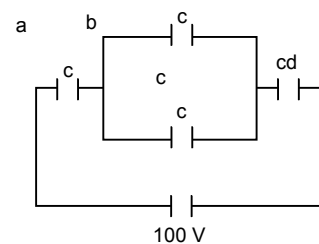
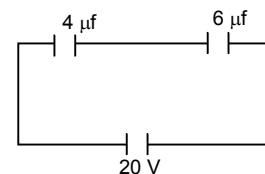

40. Initial charge stored = $C \times V = 12 \times 2 \times 10^{-6} = 24 \times 10^{-6} \text{ C}$
 Let the charges on 2 & 4 capacitors be q_1 & q_2 respectively

$$\text{There, } V = \frac{q_1}{C_1} = \frac{q_2}{C_2} \Rightarrow \frac{q_1}{2} = \frac{q_2}{4} \Rightarrow q_2 = 2q_1.$$

$$\text{or } q_1 + q_2 = 24 \times 10^{-6} \text{ C}$$

$$\Rightarrow q_1 = 8 \times 10^{-6} \mu\text{C}$$

$$q_2 = 2q_1 = 2 \times 8 \times 10^{-6} = 16 \times 10^{-6} \mu\text{C}$$

$$E_1 = (1/2) \times C_1 \times V_1^2 = (1/2) \times 2 \times \left(\frac{8}{2}\right)^2 = 16 \mu\text{J}$$

$$E_2 = (1/2) \times C_2 \times V_2^2 = (1/2) \times 4 \times \left(\frac{8}{4}\right)^2 = 8 \mu\text{J}$$

41. Charge = Q

Radius of sphere = R

\therefore Capacitance of the sphere = $C = 4\pi\epsilon_0 R$

$$\text{Energy} = \frac{1}{2} \frac{Q^2}{C} = \frac{1}{2} \frac{Q^2}{4\pi\epsilon_0 R} = \frac{Q^2}{8\pi\epsilon_0 R}$$

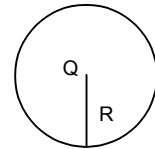

42. $Q = CV = 4\pi\epsilon_0 R \times V$

$$E = \frac{1}{2} \frac{q^2}{C} \quad [\because \text{'C' in a spherical shell} = 4 \pi \epsilon_0 R]$$

$$E = \frac{1}{2} \frac{16\pi^2 \epsilon_0^2 \times R^2 \times V^2}{4\pi\epsilon_0 \times 2R} = 2 \pi \epsilon_0 R V^2 \quad [\text{'C' of bigger shell} = 4 \pi \epsilon_0 R]$$

43. $\sigma = 1 \times 10^{-4} \text{ C/m}^2$

$$a = 1 \text{ cm} = 1 \times 10^{-2} \text{ m}$$

$$a^3 = 10^{-6} \text{ m}^3$$

$$\text{The energy stored in the plane} = \frac{1}{2} \frac{\sigma^2}{\epsilon_0} = \frac{1}{2} \frac{(1 \times 10^{-4})^2}{8.85 \times 10^{-12}} = \frac{10^4}{17.7} = 564.97$$

The necessary electro static energy stored in a cubical volume of edge 1 cm in front of the plane

$$= \frac{1}{2} \frac{\sigma^2}{\epsilon_0} a^3 = 265 \times 10^{-6} = 5.65 \times 10^{-4} \text{ J}$$

44. area = $a = 20 \text{ cm}^2 = 2 \times 10^{-2} \text{ m}^2$

d = separation = 1 mm = 10^{-3} m

$$C_i = \frac{\epsilon_0 \times 2 \times 10^{-3}}{10^{-3}} = 2\epsilon_0$$

$$C_f = \frac{\epsilon_0 \times 2 \times 10^{-3}}{2 \times 10^{-3}} = \epsilon_0$$

$q_i = 24 \epsilon_0$ $q_f = 12 \epsilon_0$ So, q flown out $12 \epsilon_0$. ie, $q_i - q_f$.

(a) So, $q = 12 \times 8.85 \times 10^{-12} = 106.2 \times 10^{-12} \text{ C} = 1.06 \times 10^{-10} \text{ C}$

(b) Energy absorbed by battery during the process

$$= q \times v = 1.06 \times 10^{-10} \text{ C} \times 12 = 12.7 \times 10^{-10} \text{ J}$$

(c) Before the process

$$E_i = (1/2) \times C_i \times v^2 = (1/2) \times 2 \times 8.85 \times 10^{-12} \times 144 = 12.7 \times 10^{-10} \text{ J}$$

After the force

$$E_f = (1/2) \times C_f \times v^2 = (1/2) \times 8.85 \times 10^{-12} \times 144 = 6.35 \times 10^{-10} \text{ J}$$

(d) Workdone = Force \times Distance

$$= \frac{1}{2} \frac{q^2}{\epsilon_0 A} = 1 \times 10^3 = \frac{1}{2} \times \frac{12 \times 12 \times \epsilon_0 \times \epsilon_0 \times 10^{-3}}{\epsilon_0 \times 2 \times 10^{-3}}$$

(e) From (c) and (d) we have calculated, the energy loss by the separation of plates is equal to the work done by the man on plate. Hence no heat is produced in transformer.

45. (a) Before reconnection

$$C = 100 \mu\text{f} \quad V = 24 \text{ V}$$

$$q = CV = 2400 \mu\text{c} \text{ (Before reconnection)}$$

After connection

$$\text{When } C = 100 \mu\text{f} \quad V = 12 \text{ V}$$

$$q = CV = 1200 \mu\text{c} \text{ (After connection)}$$

(b) $C = 100, \quad V = 12 \text{ V}$

$$\therefore q = CV = 1200 \text{ v}$$

(c) We know $V = \frac{W}{q}$

$$W = vq = 12 \times 1200 = 14400 \text{ J} = 14.4 \text{ mJ}$$

The work done on the battery.

(d) Initial electrostatic field energy $U_i = (1/2) CV_1^2$

Final Electrostatic field energy $U_f = (1/2) CV_2^2$

\therefore Decrease in Electrostatic

$$\text{Field energy} = (1/2) CV_1^2 - (1/2) CV_2^2$$

$$= (1/2) C(V_1^2 - V_2^2) = (1/2) \times 100(576 - 144) = 21600 \text{ J}$$

$$\therefore \text{Energy} = 21600 \text{ j} = 21.6 \text{ mJ}$$

(e) After reconnection

$$C = 100 \mu\text{c}, \quad V = 12 \text{ v}$$

$$\therefore \text{The energy appeared} = (1/2) CV^2 = (1/2) \times 100 \times 144 = 7200 \text{ J} = 7.2 \text{ mJ}$$

This amount of energy is developed as heat when the charge flow through the capacitor.

46. (a) Since the switch was open for a long time, hence the charge flown must be due to the both, when the switch is closed.

$$C_{\text{ef}} = C/2$$

$$\text{So } q = \frac{E \times C}{2}$$

(b) Workdone = $q \times v = \frac{EC}{2} \times E = \frac{E^2C}{2}$

(c) $E_i = \frac{1}{2} \times \frac{C}{2} \times E^2 = \frac{E^2C}{4}$

$$E_f = (1/2) \times C \times E^2 = \frac{E^2C}{2}$$

$$E_i - E_f = \frac{E^2C}{4}$$

(d) The net charge in the energy is wasted as heat.

47. $C_1 = 5 \mu\text{f} \quad V_1 = 24 \text{ V}$

$$q_1 = C_1V_1 = 5 \times 24 = 120 \mu\text{c}$$

and $C_2 = 6 \mu\text{f} \quad V_2 = R$

$$q_2 = C_2V_2 = 6 \times 12 = 72$$

\therefore Energy stored on first capacitor

$$E_1 = \frac{1}{2} \frac{q_1^2}{C_1} = \frac{1}{2} \times \frac{(120)^2}{5} = 1440 \text{ J} = 1.44 \text{ mJ}$$

Energy stored on 2nd capacitor

$$E_2 = \frac{1}{2} \frac{q_2^2}{C_2} = \frac{1}{2} \times \frac{(72)^2}{6} = 432 \text{ J} = 4.32 \text{ mJ}$$

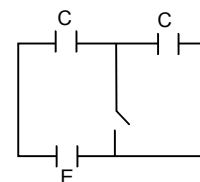

(b) C_1V_1 C_2V_2

Let the effective potential = V

$$V = \frac{C_1V_1 - C_2V_2}{C_1 + C_2} = \frac{120 - 72}{5 + 6} = 4.36$$

The new charge $C_1V = 5 \times 4.36 = 21.8 \mu\text{C}$

and $C_2V = 6 \times 4.36 = 26.2 \mu\text{C}$

(c) $U_1 = (1/2) C_1V^2$

$U_2 = (1/2) C_2V^2$

$U_f = (1/2) V^2 (C_1 + C_2) = (1/2) (4.36)^2 (5 + 6) = 104.5 \times 10^{-6} \text{ J} = 0.1045 \text{ mJ}$

But $U_i = 1.44 + 0.433 = 1.873$

\therefore The loss in KE = $1.873 - 0.1045 = 1.7687 = 1.77 \text{ mJ}$

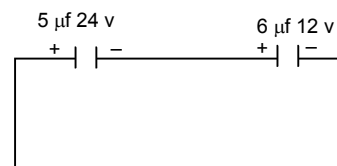

48.

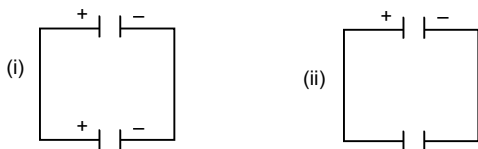

When the capacitor is connected to the battery, a charge $Q = CE$ appears on one plate and $-Q$ on the other. When the polarity is reversed, a charge $-Q$ appears on the first plate and $+Q$ on the second. A charge $2Q$, therefore passes through the battery from the negative to the positive terminal.

The battery does a work.

$W = Q \times E = 2QE = 2CE^2$

In this process. The energy stored in the capacitor is the same in the two cases. Thus the workdone by battery appears as heat in the connecting wires. The heat produced is therefore,

$2CE^2 = 2 \times 5 \times 10^{-6} \times 144 = 144 \times 10^{-5} \text{ J} = 1.44 \text{ mJ}$ [have $C = 5 \mu\text{f}$ $V = E = 12\text{V}$]

49. $A = 20 \text{ cm} \times 20 \text{ cm} = 4 \times 10^{-2} \text{ m}^2$

$d = 1 \text{ m} = 1 \times 10^{-3} \text{ m}$

$k = 4$ $t = d$

$$C = \frac{\epsilon_0 A}{d - t + \frac{t}{k}} = \frac{\epsilon_0 A}{d - d + \frac{d}{k}} = \frac{\epsilon_0 A k}{d}$$

$$= \frac{8.85 \times 10^{-12} \times 4 \times 10^{-2} \times 4}{1 \times 10^{-3}} = 141.6 \times 10^{-9} \text{ F} = 1.42 \text{ nf}$$

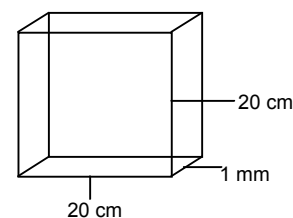

50. Dielectric const. = 4

$F = 1.42 \text{ nf}$, $V = 6 \text{ V}$

Charge supplied = $q = CV = 1.42 \times 10^{-9} \times 6 = 8.52 \times 10^{-9} \text{ C}$

Charge Induced = $q(1 - 1/k) = 8.52 \times 10^{-9} \times (1 - 0.25) = 6.39 \times 10^{-9} = 6.4 \text{ nc}$

Net charge appearing on one coated surface = $\frac{8.52 \mu\text{C}}{4} = 2.13 \text{ nc}$

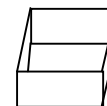

51. Here

Plate area = $100 \text{ cm}^2 = 10^{-2} \text{ m}^2$

Separation $d = .5 \text{ cm} = 5 \times 10^{-3} \text{ m}$

Thickness of metal $t = .4 \text{ cm} = 4 \times 10^{-3} \text{ m}$

$$C = \frac{\epsilon_0 A}{d - t + \frac{t}{k}} = \frac{\epsilon_0 A}{d - t} = \frac{8.585 \times 10^{-12} \times 10^{-2}}{(5 - 4) \times 10^{-3}} = 88 \text{ pF}$$

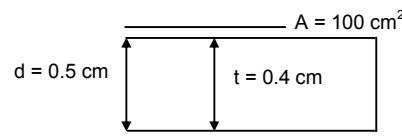

Here the capacitance is independent of the position of metal. At any position the net separation is $d - t$. As d is the separation and t is the thickness.

52. Initial charge stored = $50 \mu\text{c}$
 Let the dielectric constant of the material induced be 'k'.
 Now, when the extra charge flown through battery is 100.
 So, net charge stored in capacitor = $150 \mu\text{c}$

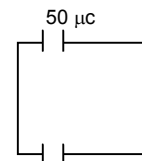

$$\text{Now } C_1 = \frac{\epsilon_0 A}{d} \quad \text{or } \frac{q_1}{V} = \frac{\epsilon_0 A}{d} \quad \dots(1)$$

$$C_2 = \frac{\epsilon_0 Ak}{d} \quad \text{or, } \frac{q_2}{V} = \frac{\epsilon_0 Ak}{d} \quad \dots(2)$$

Deviding (1) and (2) we get $\frac{q_1}{q_2} = \frac{1}{k}$

$$\Rightarrow \frac{50}{150} = \frac{1}{k} \Rightarrow k = 3$$

53. $C = 5 \mu\text{f}$ $V = 6 \text{ V}$ $d = 2 \text{ mm} = 2 \times 10^{-3} \text{ m}$.

(a) the charge on the +ve plate
 $q = CV = 5 \mu\text{f} \times 6 \text{ V} = 30 \mu\text{c}$

(b) $E = \frac{V}{d} = \frac{6\text{V}}{2 \times 10^{-3}\text{m}} = 3 \times 10^3 \text{ V/M}$

(c) $d = 2 \times 10^{-3} \text{ m}$
 $t = 1 \times 10^{-3} \text{ m}$

$$k = 5 \text{ or } C = \frac{\epsilon_0 A}{d} \Rightarrow 5 \times 10^{-6} = \frac{8.85 \times A \times 10^{-12}}{2 \times 10^{-3}} \times 10^{-9} \Rightarrow A = \frac{10^4}{8.85}$$

When the dielectric placed on it

$$C_1 = \frac{\epsilon_0 A}{d - t + \frac{t}{k}} = \frac{8.85 \times 10^{-12} \times \frac{10^4}{8.85}}{10^{-3} + \frac{10^{-3}}{5}} = \frac{10^{-12} \times 10^4 \times 5}{6 \times 10^{-3}} = \frac{5}{6} \times 10^{-5} = 0.00000833 = 8.33 \mu\text{F}.$$

(d) $C = 5 \times 10^{-6} \text{ f}$. $V = 6 \text{ V}$

$$\therefore Q = CV = 3 \times 10^{-5} \text{ f} = 30 \mu\text{f}$$

$$C' = 8.3 \times 10^{-6} \text{ f}$$

$$V = 6 \text{ V}$$

$$\therefore Q' = C'V = 8.3 \times 10^{-6} \times 6 \approx 50 \mu\text{F}$$

$$\therefore \text{charge flown} = Q' - Q = 20 \mu\text{F}$$

54. Let the capacitances be C_1 & C_2 net capacitance ' C ' = $\frac{C_1 C_2}{C_1 + C_2}$

$$\text{Now } C_1 = \frac{\epsilon_0 Ak_1}{d_1} \quad C_2 = \frac{\epsilon_0 Ak_2}{d_2}$$

$$C = \frac{\frac{\epsilon_0 Ak_1}{d_1} \times \frac{\epsilon_0 Ak_2}{d_2}}{\frac{\epsilon_0 Ak_1}{d_1} + \frac{\epsilon_0 Ak_2}{d_2}} = \frac{\epsilon_0 A \left(\frac{k_1 k_2}{d_1 d_2} \right)}{\epsilon_0 A \left(\frac{k_1 d_2 + k_2 d_1}{d_1 d_2} \right)} = \frac{8.85 \times 10^{-12} \times 10^{-2} \times 24}{6 \times 4 \times 10^{-3} + 4 \times 6 \times 10^{-3}}$$

$$= 4.425 \times 10^{-11} \text{ C} = 44.25 \text{ pc.}$$

55. $A = 400 \text{ cm}^2 = 4 \times 10^{-2} \text{ m}^2$

$$d = 1 \text{ cm} = 1 \times 10^{-3} \text{ m}$$

$$V = 160 \text{ V}$$

$$t = 0.5 = 5 \times 10^{-4} \text{ m}$$

$$k = 5$$

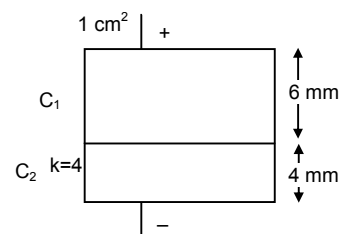

$$C = \frac{\epsilon_0 A}{d - t + \frac{t}{k}} = \frac{8.85 \times 10^{-12} \times 4 \times 10^{-2}}{10^{-3} - 5 \times 10^{-4} + \frac{5 \times 10^{-4}}{5}} = \frac{35.4 \times 10^{-4}}{10^{-3} - 0.5}$$

56. (a) Area = A
Separation = d

$$C_1 = \frac{\epsilon_0 A k_1}{d/2} \quad C_2 = \frac{\epsilon_0 A k_2}{d/2}$$

$$C = \frac{C_1 C_2}{C_1 + C_2} = \frac{\frac{2\epsilon_0 A k_1}{d} \times \frac{2\epsilon_0 A k_2}{d}}{\frac{2\epsilon_0 A k_1}{d} + \frac{2\epsilon_0 A k_2}{d}} = \frac{(2\epsilon_0 A)^2 k_1 k_2}{(2\epsilon_0 A) \frac{k_1 d + k_2 d}{d}} = \frac{2k_1 k_2 \epsilon_0 A}{d(k_1 + k_2)}$$

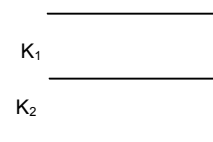

(b) similarly

$$\frac{1}{C} = \frac{1}{C_1} + \frac{1}{C_2} + \frac{1}{C_3} = \frac{1}{\frac{3\epsilon_0 A k_1}{d}} + \frac{1}{\frac{3\epsilon_0 A k_2}{d}} + \frac{1}{\frac{3\epsilon_0 A k_3}{d}}$$

$$= \frac{d}{3\epsilon_0 A} \left[\frac{1}{k_1} + \frac{1}{k_2} + \frac{1}{k_3} \right] = \frac{d}{3\epsilon_0 A} \left[\frac{k_2 k_3 + k_1 k_3 + k_1 k_2}{k_1 k_2 k_3} \right]$$

$$\therefore C = \frac{3\epsilon_0 A k_1 k_2 k_3}{d(k_1 k_2 + k_2 k_3 + k_1 k_3)}$$

(c) $C = C_1 + C_2$

$$= \frac{\epsilon_0 \frac{A}{2} k_1}{d} + \frac{\epsilon_0 \frac{A}{2} k_2}{d} = \frac{\epsilon_0 A}{2d} (k_1 + k_2)$$

57.

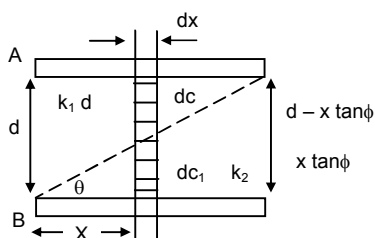

Consider an elemental capacitor of with dx our at a distance 'x' from one end. It is constituted of two capacitor elements of dielectric constants k_1 and k_2 with plate separation $x \tan \phi$ and $d - x \tan \phi$ respectively in series

$$\frac{1}{dcR} = \frac{1}{dc_1} + \frac{1}{dc_2} = \frac{x \tan \phi}{\epsilon_0 k_2 (bdx)} + \frac{d - x \tan \phi}{\epsilon_0 k_1 (bdx)}$$

$$dcR = \frac{\epsilon_0 bdx}{\frac{x \tan \phi}{k_2} + \frac{d - x \tan \phi}{k_1}}$$

$$\text{or } C_R = \epsilon_0 b k_1 k_2 \int \frac{dx}{k_2 d + (k_1 - k_2) x \tan \phi}$$

$$= \frac{\epsilon_0 b k_1 k_2}{\tan \phi (k_1 - k_2)} [\log_e k_2 d + (k_1 - k_2) x \tan \phi] a$$

$$= \frac{\epsilon_0 b k_1 k_2}{\tan \phi (k_1 - k_2)} [\log_e k_2 d + (k_1 - k_2) a \tan \phi - \log_e k_2 d]$$

$$\therefore \tan \phi = \frac{d}{a} \text{ and } A = a \times a$$

$$C_R = \frac{\epsilon_0 a k_1 k_2}{d(k_1 - k_2)} \left[\log_e \left(\frac{k_1}{k_2} \right) \right]$$

$$C_R = \frac{\epsilon_0 a^2 k_1 k_2}{d(k_1 - k_2)} \left[\log_e \left(\frac{k_1}{k_2} \right) \right]$$

$$C_R = \frac{\epsilon_0 a^2 k_1 k_2}{d(k_1 - k_2)} \ln \frac{k_1}{k_2}$$

58.

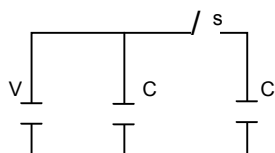

I. Initially when switch 's' is closed

$$\text{Total Initial Energy} = (1/2) CV^2 + (1/2) CV^2 = CV^2 \quad \dots(1)$$

II. When switch is open the capacitance in each of capacitors varies, hence the energy also varies.

i.e. in case of 'B', the charge remains

Same i.e. cv

$$C_{\text{eff}} = 3C$$

$$E = \frac{1}{2} \times \frac{q^2}{c} = \frac{1}{2} \times \frac{c^2 v^2}{3c} = \frac{cv^2}{6}$$

In case of 'A'

$$C_{\text{eff}} = 3c$$

$$E = \frac{1}{2} \times C_{\text{eff}} v^2 = \frac{1}{2} \times 3c \times v^2 = \frac{3}{2} cv^2$$

$$\text{Total final energy} = \frac{cv^2}{6} + \frac{3cv^2}{2} = \frac{10cv^2}{6}$$

$$\text{Now, } \frac{\text{Initial Energy}}{\text{Final Energy}} = \frac{cv^2}{\frac{10cv^2}{6}} = 3$$

59. Before inserting

$$C = \frac{\epsilon_0 A}{d} C \quad Q = \frac{\epsilon_0 AV}{d} C$$

After inserting

$$C = \frac{\epsilon_0 A}{d} = \frac{\epsilon_0 Ak}{d} \quad Q_1 = \frac{\epsilon_0 Ak}{d} V$$

The charge flow through the power supply

$$Q = Q_1 - Q$$

$$= \frac{\epsilon_0 AkV}{d} - \frac{\epsilon_0 AV}{d} = \frac{\epsilon_0 AV}{d} (k - 1)$$

Workdone = Charge in emf

$$= \frac{1}{2} \frac{q^2}{C} = \frac{1}{2} \frac{\epsilon_0^2 A^2 V^2 (k - 1)^2}{\frac{\epsilon_0 A}{d} (k - 1)} = \frac{\epsilon_0 AV^2}{2d} (k - 1)$$

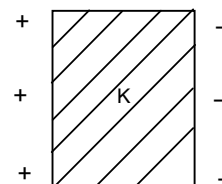

60. Capacitance = $100 \mu\text{F} = 10^{-4} \text{ F}$

P.d = 30 V

(a) $q = CV = 10^{-4} \times 50 = 5 \times 10^{-3} \text{ C} = 5 \text{ mC}$

Dielectric constant = 2.5

(b) New $C = C' = 2.5 \times C = 2.5 \times 10^{-4} \text{ F}$

New p.d = $\frac{q}{C'}$ [\therefore 'q' remains same after disconnection of battery]

= $\frac{5 \times 10^{-3}}{2.5 \times 10^{-4}} = 20 \text{ V.}$

(c) In the absence of the dielectric slab, the charge that must have produced

$C \times V = 10^{-4} \times 20 = 2 \times 10^{-3} \text{ C} = 2 \text{ mC}$

(d) Charge induced at a surface of the dielectric slab

= $q (1 - 1/k)$ (where k = dielectric constant, q = charge of plate)

= $5 \times 10^{-3} \left(1 - \frac{1}{2.5}\right) = 5 \times 10^{-3} \times \frac{3}{5} = 3 \times 10^{-3} = 3 \text{ mC.}$

61. Here we should consider a capacitor C_{ac} and C_{bc} in series

$C_{ac} = \frac{4\pi\epsilon_0ack}{k(c-a)}$

$C_{bc} = \frac{4\pi\epsilon_0bc}{(b-c)}$

$\frac{1}{C} = \frac{1}{C_{ac}} + \frac{1}{C_{bc}}$

= $\frac{(c-a)}{4\pi\epsilon_0ack} + \frac{(b-c)}{4\pi\epsilon_0bc} = \frac{b(c-a) + ka(b-c)}{k4\pi\epsilon_0abc}$

$C = \frac{4\pi\epsilon_0kabc}{ka(b-c) + b(c-a)}$

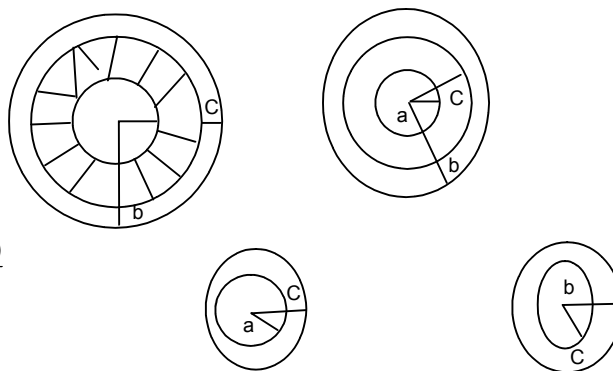

62. These three metallic hollow spheres form two spherical capacitors, which are connected in series.

Solving them individually, for (1) and (2)

$C_1 = \frac{4\pi\epsilon_0ab}{b-a}$ (\therefore for a spherical capacitor formed by two spheres of radii $R_2 > R_1$)

$C = \frac{4\pi\epsilon_0R_2R_1}{R_2 - R_1}$

Similarly for (2) and (3)

$C_2 = \frac{4\pi\epsilon_0bc}{c-b}$

$C_{\text{eff}} = \frac{C_1 C_2}{C_1 + C_2} = \frac{\frac{(4\pi\epsilon_0)^2 ab^2c}{(b-a)(c-a)}}{4\pi\epsilon_0 \left[\frac{ab(c-b) + bc(b-a)}{(b-a)(c-b)} \right]}$

= $\frac{4\pi\epsilon_0 ab^2c}{abc - ab^2 + b^2c - abc} = \frac{4\pi\epsilon_0 ab^2c}{b^2(c-a)} = \frac{4\pi\epsilon_0 ac}{c-a}$

63. Here we should consider two spherical capacitor of capacitance

C_{ab} and C_{bc} in series

$C_{ab} = \frac{4\pi\epsilon_0abk}{(b-a)}$

$C_{bc} = \frac{4\pi\epsilon_0bc}{(c-b)}$

$$\frac{1}{C} = \frac{1}{C_{ab}} + \frac{1}{C_{bc}} = \frac{(b-a)}{4\pi\epsilon_0 abk} + \frac{(c-b)}{4\pi\epsilon_0 bc} = \frac{c(b-a) + ka(c-b)}{k4\pi\epsilon_0 abc}$$

$$C = \frac{4\pi\epsilon_0 kabc}{c(b-a) + ka(c-b)}$$

64. $Q = 12 \mu\text{C}$

$V = 1200 \text{ V}$

$$\frac{V}{d} = 3 \times 10^{-6} \frac{V}{\text{m}}$$

$$d = \frac{V}{(V/d)} = \frac{1200}{3 \times 10^{-6}} = 4 \times 10^{-4} \text{ m}$$

$$c = \frac{Q}{V} = \frac{12 \times 10^{-6}}{1200} = 10^{-8} \text{ f}$$

$$\therefore C = \frac{\epsilon_0 A}{d} = 10^{-8} \text{ f}$$

$$\Rightarrow A = \frac{10^{-8} \times d}{\epsilon_0} = \frac{10^{-8} \times 4 \times 10^{-4}}{8.854 \times 10^{-4}} = 0.45 \text{ m}^2$$

65. $A = 100 \text{ cm}^2 = 10^{-2} \text{ m}^2$

$d = 1 \text{ cm} = 10^{-2} \text{ m}$

$V = 24 \text{ V}_0$

$$\therefore \text{The capacitance } C = \frac{\epsilon_0 A}{d} = \frac{8.85 \times 10^{-12} \times 10^{-2}}{10^{-2}} = 8.85 \times 10^{-12}$$

$$\therefore \text{The energy stored } C_1 = (1/2) CV^2 = (1/2) \times 10^{-12} \times (24)^2 = 2548.8 \times 10^{-12}$$

$$\therefore \text{The forced attraction between the plates} = \frac{C_1}{d} = \frac{2548.8 \times 10^{-12}}{10^{-2}} = 2.54 \times 10^{-7} \text{ N.}$$

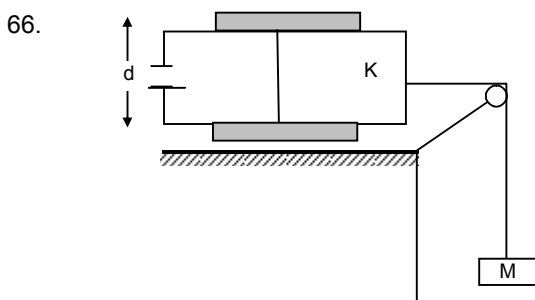

We know

In this particular case the electric field attracts the dielectric into the capacitor with a force $\frac{\epsilon_0 bV^2(k-1)}{2d}$

Where b – Width of plates

k – Dielectric constant

d – Separation between plates

$V = E =$ Potential difference.

Hence in this case the surfaces are frictionless, this force is counteracted by the weight.

$$\text{So, } \frac{\epsilon_0 bE^2(k-1)}{2d} = Mg$$

$$\Rightarrow M = \frac{\epsilon_0 bE^2(k-1)}{2dg}$$

67.

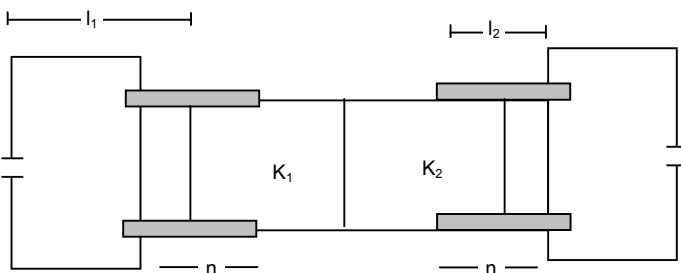

(a) Consider the left side

The plate area of the part with the dielectric is by its capacitance

$$C_1 = \frac{k_1 \epsilon_0 b x}{d} \text{ and with out dielectric } C_2 = \frac{\epsilon_0 b (L_1 - x)}{d}$$

These are connected in parallel

$$C = C_1 + C_2 = \frac{\epsilon_0 b}{d} [L_1 + x(k_1 - 1)]$$

Let the potential V_1

$$U = (1/2) CV_1^2 = \frac{\epsilon_0 b V_1^2}{2d} [L_1 + x(k_1 - 1)] \quad \dots(1)$$

Suppose dielectric slab is attracted by electric field and an external force F consider the part dx which makes inside further, As the potential difference remains constant at V .

The charge supply, $dq = (dc) v$ to the capacitor

The work done by the battery is $dw_b = v \cdot dq = (dc) v^2$

The external force F does a work $dw_e = (-f \cdot dx)$

during a small displacement

The total work done in the capacitor is $dw_b + dw_e = (dc) v^2 - f dx$

This should be equal to the increase dv in the stored energy.

Thus $(1/2) (dk) v^2 = (dc) v^2 - f dx$

$$f = \frac{1}{2} v^2 \frac{dc}{dx}$$

from equation (1)

$$F = \frac{\epsilon_0 b V^2}{2d} (k_1 - 1)$$

$$\Rightarrow V_1^2 = \frac{F \times 2d}{\epsilon_0 b (k_1 - 1)} \Rightarrow V_1 = \sqrt{\frac{F \times 2d}{\epsilon_0 b (k_1 - 1)}}$$

$$\text{For the right side, } V_2 = \sqrt{\frac{F \times 2d}{\epsilon_0 b (k_2 - 1)}}$$

$$\frac{V_1}{V_2} = \frac{\sqrt{\frac{F \times 2d}{\epsilon_0 b (k_1 - 1)}}}{\sqrt{\frac{F \times 2d}{\epsilon_0 b (k_2 - 1)}}}$$

$$\Rightarrow \frac{V_1}{V_2} = \frac{\sqrt{k_2 - 1}}{\sqrt{k_1 - 1}}$$

\therefore The ratio of the emf of the left battery to the right battery = $\frac{\sqrt{k_2 - 1}}{\sqrt{k_1 - 1}}$

68. Capacitance of the portion with dielectrics,

$$C_1 = \frac{k\epsilon_0 A}{\ell d}$$

Capacitance of the portion without dielectrics,

$$C_2 = \frac{\epsilon_0(\ell - a)A}{\ell d}$$

$$\therefore \text{Net capacitance } C = C_1 + C_2 = \frac{\epsilon_0 A}{\ell d} [ka + (\ell - a)]$$

$$C = \frac{\epsilon_0 A}{\ell d} [\ell + a(k - 1)]$$

Consider the motion of dielectric in the capacitor.

Let it further move a distance dx , which causes an increase of capacitance by dc

$$\therefore dQ = (dc) E$$

$$\text{The work done by the battery } dw = Vdq = E (dc) E = E^2 dc$$

Let force acting on it be f

$$\therefore \text{Work done by the force during the displacement, } dx = f dx$$

$$\therefore \text{Increase in energy stored in the capacitor}$$

$$\Rightarrow (1/2) (dc) E^2 = (dc) E^2 - f dx$$

$$\Rightarrow f dx = (1/2) (dc) E^2 \Rightarrow f = \frac{1}{2} \frac{E^2 dc}{dx}$$

$$C = \frac{\epsilon_0 A}{\ell d} [\ell + a(k - 1)] \quad (\text{here } x = a)$$

$$\Rightarrow \frac{dc}{da} = \frac{-d}{da} \left[\frac{\epsilon_0 A}{\ell d} \{ \ell + a(k - 1) \} \right]$$

$$\Rightarrow \frac{\epsilon_0 A}{\ell d} (k - 1) = \frac{dc}{dx}$$

$$\Rightarrow f = \frac{1}{2} E^2 \frac{dc}{dx} = \frac{1}{2} E^2 \left\{ \frac{\epsilon_0 A}{\ell d} (k - 1) \right\}$$

$$\therefore a_d = \frac{f}{m} = \frac{E^2 \epsilon_0 A (k - 1)}{2 \ell d m} \quad \therefore (\ell - a) = \frac{1}{2} a_d t^2$$

$$\Rightarrow t = \sqrt{\frac{2(\ell - a)}{a_d}} = \sqrt{\frac{2(\ell - a) 2 \ell d m}{E^2 \epsilon_0 A (k - 1)}} = \sqrt{\frac{4 m \ell d (\ell - a)}{\epsilon_0 A E^2 (k - 1)}}$$

$$\therefore \text{Time period} = 2t = \sqrt{\frac{8 m \ell d (\ell - a)}{\epsilon_0 A E^2 (k - 1)}}$$

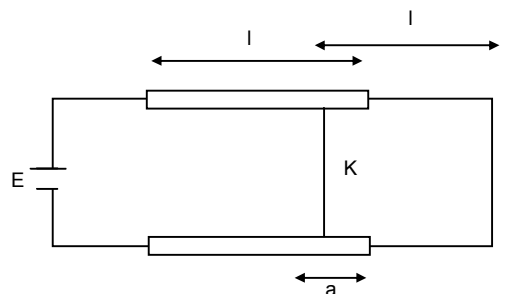

ELECTRIC CURRENT IN CONDUCTORS CHAPTER - 32

1. $Q(t) = At^2 + Bt + c$

a) $At^2 = Q$

$$\Rightarrow A = \frac{Q}{t^2} = \frac{A'T'}{T^{-2}} = A^1 T^{-1}$$

b) $Bt = Q$

$$\Rightarrow B = \frac{Q}{t} = \frac{A'T'}{T} = A$$

c) $C = [Q]$

$$\Rightarrow C = A'T'$$

d) Current $i = \frac{dQ}{dt} = \frac{d}{dt}(At^2 + Bt + C)$

$$= 2At + B = 2 \times 5 \times 5 + 3 = 53 \text{ A.}$$

2. No. of electrons per second = 2×10^{16} electrons / sec.

$$\text{Charge passing per second} = 2 \times 10^{16} \times 1.6 \times 10^{-9} \frac{\text{coulomb}}{\text{sec}}$$

$$= 3.2 \times 10^{-9} \text{ Coulomb/sec}$$

$$\text{Current} = 3.2 \times 10^{-3} \text{ A.}$$

3. $i' = 2 \mu\text{A}$, $t = 5 \text{ min} = 5 \times 60 \text{ sec.}$

$$q = i t = 2 \times 10^{-6} \times 5 \times 60$$

$$= 10 \times 60 \times 10^{-6} \text{ c} = 6 \times 10^{-4} \text{ c}$$

4. $i = i_0 + \alpha t$, $t = 10 \text{ sec}$, $i_0 = 10 \text{ A}$, $\alpha = 4 \text{ A/sec.}$

$$q = \int_0^t i dt = \int_0^t (i_0 + \alpha t) dt = \int_0^t i_0 dt + \int_0^t \alpha t dt$$

$$= i_0 t + \alpha \frac{t^2}{2} = 10 \times 10 + 4 \times \frac{10 \times 10}{2}$$

$$= 100 + 200 = 300 \text{ C.}$$

5. $i = 1 \text{ A}$, $A = 1 \text{ mm}^2 = 1 \times 10^{-6} \text{ m}^2$

$$f' \text{ cu} = 9000 \text{ kg/m}^3$$

Molecular mass has N_0 atoms

$$= m \text{ Kg has } (N_0/M \times m) \text{ atoms} = \frac{N_0 A i 9000}{63.5 \times 10^{-3}}$$

No. of atoms = No. of electrons

$$n = \frac{\text{No. of electrons}}{\text{Unit volume}} = \frac{N_0 A i f}{m A l} = \frac{N_0 i f}{M}$$

$$= \frac{6 \times 10^{23} \times 9000}{63.5 \times 10^{-3}}$$

$$i = V_d n A e.$$

$$\Rightarrow V_d = \frac{i}{n A e} = \frac{1}{\frac{6 \times 10^{23} \times 9000}{63.5 \times 10^{-3}} \times 10^{-6} \times 1.6 \times 10^{-19}}$$

$$= \frac{63.5 \times 10^{-3}}{6 \times 10^{23} \times 9000 \times 10^{-6} \times 1.6 \times 10^{-19}} = \frac{63.5 \times 10^{-3}}{6 \times 9 \times 1.6 \times 10^{26} \times 10^{-19} \times 10^{-6}}$$

$$= \frac{63.5 \times 10^{-3}}{6 \times 9 \times 1.6 \times 10} = \frac{63.5 \times 10^{-3}}{6 \times 9 \times 16}$$

$$= 0.074 \times 10^{-3} \text{ m/s} = 0.074 \text{ mm/s.}$$

6. $\ell = 1 \text{ m}, r = 0.1 \text{ mm} = 0.1 \times 10^{-3} \text{ m}$

$R = 100 \Omega, f = ?$

$\Rightarrow R = f \ell / a$

$$\Rightarrow f = \frac{Ra}{\ell} = \frac{100 \times 3.14 \times 0.1 \times 0.1 \times 10^{-6}}{1}$$

$$= 3.14 \times 10^{-6} = \pi \times 10^{-6} \Omega\text{-m.}$$

7. $\ell' = 2 \ell$

volume of the wire remains constant.

$$A \ell = A' \ell'$$

$$\Rightarrow A \ell = A' \times 2 \ell$$

$$\Rightarrow A' = A/2$$

$f =$ Specific resistance

$$R = \frac{f \ell}{A} ; R' = \frac{f \ell'}{A'}$$

$$100 \Omega = \frac{f 2 \ell}{A/2} = \frac{4 f \ell}{A} = 4R$$

$$\Rightarrow 4 \times 100 \Omega = 400 \Omega$$

8. $\ell = 4 \text{ m}, A = 1 \text{ mm}^2 = 1 \times 10^{-6} \text{ m}^2$

$I = 2 \text{ A}, n/V = 10^{29}, t = ?$

$i = n A V_d e$

$$\Rightarrow e = 10^{29} \times 1 \times 10^{-6} \times V_d \times 1.6 \times 10^{-19}$$

$$\Rightarrow V_d = \frac{2}{10^{29} \times 10^{-6} \times 1.6 \times 10^{-19}}$$

$$= \frac{1}{0.8 \times 10^4} = \frac{1}{8000}$$

$$t = \frac{\ell}{V_d} = \frac{4}{1/8000} = 4 \times 8000$$

$$= 32000 = 3.2 \times 10^4 \text{ sec.}$$

9. $f_{\text{cu}} = 1.7 \times 10^{-8} \Omega\text{-m}$

$A = 0.01 \text{ mm}^2 = 0.01 \times 10^{-6} \text{ m}^2$

$R = 1 \text{ K}\Omega = 10^3 \Omega$

$$R = \frac{f \ell}{a}$$

$$\Rightarrow 10^3 = \frac{1.7 \times 10^{-8} \times \ell}{10^{-6}}$$

$$\Rightarrow \ell = \frac{10^3}{1.7} = 0.58 \times 10^3 \text{ m} = 0.6 \text{ km.}$$

10. dR , due to the small strip dx at a distance x $d = R = \frac{f dx}{\pi y^2} \dots(1)$

$$\tan \theta = \frac{y-a}{x} = \frac{b-a}{L}$$

$$\Rightarrow \frac{y-a}{x} = \frac{b-a}{L}$$

$$\Rightarrow L(y-a) = x(b-a)$$

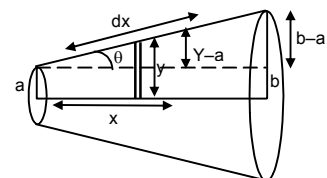

$$\Rightarrow Ly - La = xb - xa$$

$$\Rightarrow L \frac{dy}{dx} - 0 = b - a \text{ (diff. w.r.t. } x)$$

$$\Rightarrow L \frac{dy}{dx} = b - a$$

$$\Rightarrow dx = \frac{Ldy}{b-a} \quad \dots(2)$$

Putting the value of dx in equation (1)

$$dR = \frac{fLdy}{\pi y^2(b-a)}$$

$$\Rightarrow dR = \frac{fl}{\pi(b-a)} \frac{dy}{y^2}$$

$$\Rightarrow \int_0^R dR = \frac{fl}{\pi(b-a)} \int_a^b \frac{dy}{y^2}$$

$$\Rightarrow R = \frac{fl}{\pi(b-a)} \frac{(b-a)}{ab} = \frac{fl}{\pi ab}$$

11. $r = 0.1 \text{ mm} = 10^{-4} \text{ m}$

$R = 1 \text{ K}\Omega = 10^3 \Omega, V = 20 \text{ V}$

a) No. of electrons transferred

$$i = \frac{V}{R} = \frac{20}{10^3} = 20 \times 10^{-3} = 2 \times 10^{-2} \text{ A}$$

$$q = it = 2 \times 10^{-2} \times 1 = 2 \times 10^{-2} \text{ C.}$$

$$\text{No. of electrons transferred} = \frac{2 \times 10^{-2}}{1.6 \times 10^{-19}} = \frac{2 \times 10^{-17}}{1.6} = 1.25 \times 10^{17}.$$

b) Current density of wire

$$= \frac{i}{A} = \frac{2 \times 10^{-2}}{\pi \times 10^{-8}} = \frac{2}{3.14} \times 10^{+6}$$

$$= 0.6369 \times 10^{+6} = 6.37 \times 10^5 \text{ A/m}^2.$$

12. $A = 2 \times 10^{-6} \text{ m}^2, I = 1 \text{ A}$

$f = 1.7 \times 10^{-8} \Omega\text{-m}$

$E = ?$

$$R = \frac{f\ell}{A} = \frac{1.7 \times 10^{-8} \times \ell}{2 \times 10^{-6}}$$

$$V = IR = \frac{1 \times 1.7 \times 10^{-8} \times \ell}{2 \times 10^{-6}}$$

$$E = \frac{dV}{dL} = \frac{V}{l} = \frac{1.7 \times 10^{-8} \times \ell}{2 \times 10^{-6} \ell} = \frac{1.7}{2} \times 10^{-2} \text{ V/m}$$

$$= 8.5 \text{ mV/m.}$$

13. $l = 2 \text{ m}, R = 5 \Omega, i = 10 \text{ A}, E = ?$

$V = iR = 10 \times 5 = 50 \text{ V}$

$$E = \frac{V}{l} = \frac{50}{2} = 25 \text{ V/m.}$$

14. $R'_{Fe} = R_{Fe} (1 + \alpha_{Fe} \Delta\theta), R'_{Cu} = R_{Cu} (1 + \alpha_{Cu} \Delta\theta)$

$R'_{Fe} = R'_{Cu}$

$\Rightarrow R_{Fe} (1 + \alpha_{Fe} \Delta\theta) = R_{Cu} (1 + \alpha_{Cu} \Delta\theta)$

$$\begin{aligned} &\Rightarrow 3.9 [1 + 5 \times 10^{-3} (20 - \theta)] = 4.1 [1 + 4 \times 10^{-3} (20 - \theta)] \\ &\Rightarrow 3.9 + 3.9 \times 5 \times 10^{-3} (20 - \theta) = 4.1 + 4.1 \times 4 \times 10^{-3} (20 - \theta) \\ &\Rightarrow 4.1 \times 4 \times 10^{-3} (20 - \theta) - 3.9 \times 5 \times 10^{-3} (20 - \theta) = 3.9 - 4.1 \\ &\Rightarrow 16.4(20 - \theta) - 19.5(20 - \theta) = 0.2 \times 10^3 \\ &\Rightarrow (20 - \theta) (-3.1) = 0.2 \times 10^3 \\ &\Rightarrow \theta - 20 = 200 \\ &\Rightarrow \theta = 220^\circ\text{C}. \end{aligned}$$

15. Let the voltmeter reading when the voltage is 0 be X.

$$\begin{aligned} \frac{I_1 R}{I_2 R} &= \frac{V_1}{V_2} \\ \Rightarrow \frac{1.75}{2.75} &= \frac{14.4 - V}{22.4 - V} \Rightarrow \frac{0.35}{0.55} = \frac{14.4 - V}{22.4 - V} \\ \Rightarrow \frac{0.07}{0.11} &= \frac{14.4 - V}{22.4 - V} \Rightarrow \frac{7}{11} = \frac{14.4 - V}{22.4 - V} \\ \Rightarrow 7(22.4 - V) &= 11(14.4 - V) \Rightarrow 156.8 - 7V = 158.4 - 11V \\ \Rightarrow (7 - 11)V &= 156.8 - 158.4 \Rightarrow -4V = -1.6 \\ \Rightarrow V &= 0.4 \text{ V}. \end{aligned}$$

16. a) When switch is open, no current passes through the ammeter. In the upper part of the circuit the Voltmeter has ∞ resistance. Thus current in it is 0.

\therefore Voltmeter read the emf. (There is not Pot. Drop across the resistor).

- b) When switch is closed current passes through the circuit and if its value of i.

The voltmeter reads

$$\varepsilon - ir = 1.45$$

$$\begin{aligned} \Rightarrow 1.52 - ir &= 1.45 \\ \Rightarrow ir &= 0.07 \\ \Rightarrow 1 r &= 0.07 \Rightarrow r = 0.07 \Omega. \end{aligned}$$

17. $E = 6 \text{ V}$, $r = 1 \Omega$, $V = 5.8 \text{ V}$, $R = ?$

$$\begin{aligned} I &= \frac{E}{R+r} = \frac{6}{R+1}, V = E - Ir \\ \Rightarrow 5.8 &= 6 - \frac{6}{R+1} \times 1 \Rightarrow \frac{6}{R+1} = 0.2 \\ \Rightarrow R + 1 &= 30 \Rightarrow R = 29 \Omega. \end{aligned}$$

18. $V = \varepsilon + ir$

$$\begin{aligned} \Rightarrow 7.2 &= 6 + 2 \times r \\ \Rightarrow 1.2 &= 2r \Rightarrow r = 0.6 \Omega. \end{aligned}$$

19. a) net emf while charging

$$\begin{aligned} 9 - 6 &= 3\text{V} \\ \text{Current} &= 3/10 = 0.3 \text{ A} \end{aligned}$$

- b) When completely charged.

$$\begin{aligned} \text{Internal resistance 'r'} &= 1 \Omega \\ \text{Current} &= 3/1 = 3 \text{ A} \end{aligned}$$

20. a) $0.1i_1 + 1 i_1 - 6 + 1i_1 - 6 = 0$

$$\begin{aligned} \Rightarrow 0.1 i_1 + 1i_1 + 1i_1 &= 12 \\ \Rightarrow i_1 &= \frac{12}{2.1} \end{aligned}$$

ABCD

$$\begin{aligned} \Rightarrow 0.1i_2 + 1i_1 - 6 &= 0 \\ \Rightarrow 0.1i_2 + 1i_1 &= 6 \end{aligned}$$

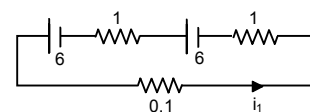
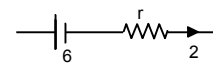
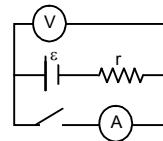

ADEFA,

$$\begin{aligned} \Rightarrow i - 6 + 6 - (i_2 - i)1 &= 0 \\ \Rightarrow i - i_2 + i &= 0 \\ \Rightarrow 2i - i_2 = 0 \Rightarrow -2i \pm 0.2i &= 0 \\ \Rightarrow i_2 &= 0. \end{aligned}$$

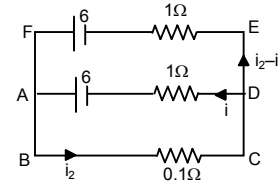

b) $1i_1 + 1i_1 - 6 + 1i_1 = 0$
 $\Rightarrow 3i_1 = 12 \Rightarrow i_1 = 4$

DCFED

$$\Rightarrow i_2 + i - 6 = 0 \Rightarrow i_2 + i = 6$$

ABCD,

$$\begin{aligned} i_2 + (i_2 - i) - 6 &= 0 \\ \Rightarrow i_2 + i_2 - i &= 6 \Rightarrow 2i_2 - i = 6 \\ \Rightarrow -2i_2 \pm 2i &= 6 \Rightarrow i = -2 \\ i_2 + i &= 6 \\ \Rightarrow i_2 - 2 &= 6 \Rightarrow i_2 = 8 \\ \frac{i_1}{i_2} &= \frac{4}{8} = \frac{1}{2}. \end{aligned}$$

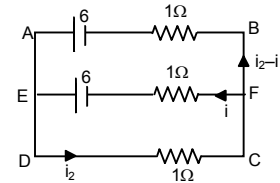
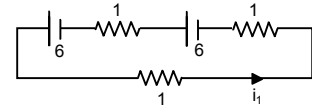

c) $10i_1 + 1i_1 - 6 + 1i_1 - 6 = 0$
 $\Rightarrow 12i_1 = 12 \Rightarrow i_1 = 1$
 $10i_2 - i_1 - 6 = 0$
 $\Rightarrow 10i_2 - i_1 = 6$
 $\Rightarrow 10i_2 + (i_2 - i)1 - 6 = 0$
 $\Rightarrow 11i_2 = 6$
 $\Rightarrow -i_2 = 0$

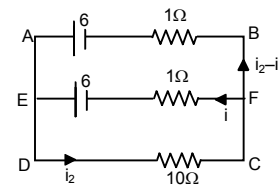
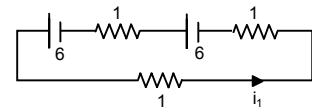

21. a) Total emf = n_1E

in 1 row

Total emf in all news = n_1E

Total resistance in one row = n_1r

Total resistance in all rows = $\frac{n_1r}{n_2}$

Net resistance = $\frac{n_1r}{n_2} + R$

Current = $\frac{n_1E}{n_1/n_2r + R} = \frac{n_1n_2E}{n_1r + n_2R}$

b) $I = \frac{n_1n_2E}{n_1r + n_2R}$

for I = max,

$$n_1r + n_2R = \min$$

$$\Rightarrow (\sqrt{n_1r} - \sqrt{n_2R})^2 + 2\sqrt{n_1n_2R} = \min$$

it is min, when

$$\sqrt{n_1r} = \sqrt{n_2R}$$

$$\Rightarrow n_1r = n_2R$$

I is max when $n_1r = n_2R$.

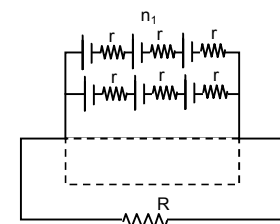

22. $E = 100 \text{ V}$, $R' = 100 \text{ k}\Omega = 100000 \Omega$

$R = 1 - 100$

When no other resistor is added or $R = 0$.

$$i = \frac{E}{R'} = \frac{100}{100000} = 0.001 \text{ Amp}$$

When $R = 1$

$$i = \frac{100}{100000 + 1} = \frac{100}{100001} = 0.0009 \text{ A}$$

When $R = 100$

$$i = \frac{100}{100000 + 100} = \frac{100}{100100} = 0.000999 \text{ A}$$

Upto $R = 100$ the current does not upto 2 significant digits. Thus it proved.

23. $A_1 = 2.4 \text{ A}$

Since A_1 and A_2 are in parallel,

$$\Rightarrow 20 \times 2.4 = 30 \times X$$

$$\Rightarrow X = \frac{20 \times 2.4}{30} = 1.6 \text{ A}$$

Reading in Ammeter A_2 is 1.6 A .

$$A_3 = A_1 + A_2 = 2.4 + 1.6 = 4.0 \text{ A}$$

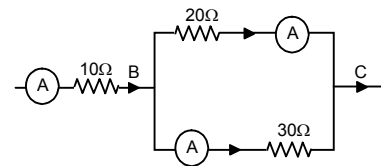

24.

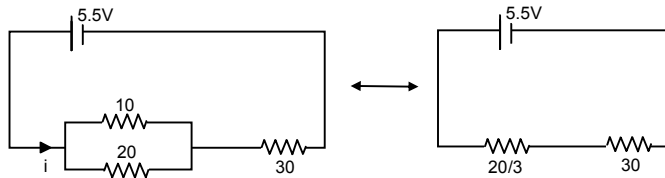
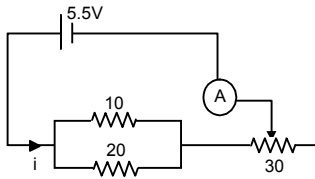

$$i_{\min} = \frac{5.5 \times 3}{110} = 0.15$$

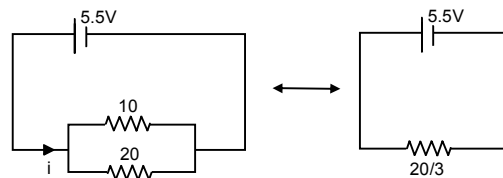

$$i_{\max} = \frac{5.5 \times 3}{20} = \frac{16.5}{20} = 0.825$$

25. a) $R_{\text{eff}} = \frac{180}{3} = 60 \Omega$

$$i = 60 / 60 = 1 \text{ A}$$

b) $R_{\text{eff}} = \frac{180}{2} = 90 \Omega$

$$i = 60 / 90 = 0.67 \text{ A}$$

c) $R_{\text{eff}} = 180 \Omega \Rightarrow i = 60 / 180 = 0.33 \text{ A}$

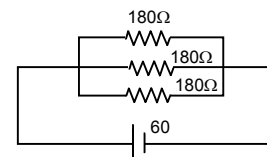

26. Max. $R = (20 + 50 + 100) \Omega = 170 \Omega$

$$\text{Min } R = \frac{1}{\left(\frac{1}{20} + \frac{1}{50} + \frac{1}{100}\right)} = \frac{100}{8} = 12.5 \Omega.$$

27. The various resistances of the bulbs = $\frac{V^2}{P}$

$$\text{Resistances are } \frac{(15)^2}{10}, \frac{(15)^2}{10}, \frac{(15)^2}{15} = 45, 22.5, 15.$$

Since two resistances when used in parallel have resistances less than both.

The resistances are 45 and 22.5.

28. $i_1 \times 20 = i_2 \times 10$

$$\Rightarrow \frac{i_1}{i_2} = \frac{10}{20} = \frac{1}{2}$$

$$i_1 = 4 \text{ mA}, i_2 = 8 \text{ mA}$$

Current in 20 K Ω resistor = 4 mA

Current in 10 K Ω resistor = 8 mA

Current in 100 K Ω resistor = 12 mA

$$V = V_1 + V_2 + V_3$$

$$= 5 \text{ K}\Omega \times 12 \text{ mA} + 10 \text{ K}\Omega \times 8 \text{ mA} + 100 \text{ K}\Omega \times 12 \text{ mA}$$

$$= 60 + 80 + 1200 = 1340 \text{ volts.}$$

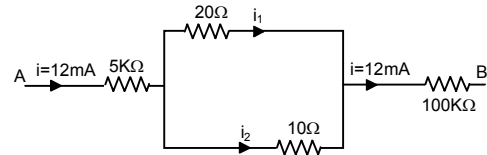

29. $R_1 = R, i_1 = 5 \text{ A}$

$$R_2 = \frac{10R}{10+R}, i_2 = 6 \text{ A}$$

Since potential constant,

$$i_1 R_1 = i_2 R_2$$

$$\Rightarrow 5 \times R = \frac{6 \times 10R}{10+R}$$

$$\Rightarrow (10 + R)5 = 60$$

$$\Rightarrow 5R = 10 \Rightarrow R = 2 \Omega.$$

30.

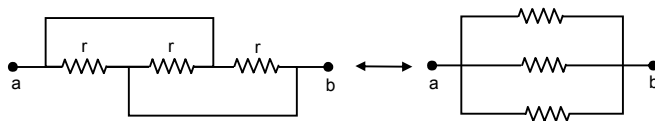

Eq. Resistance = $r/3$.

31. a) $R_{\text{eff}} = \frac{\frac{15 \times 5}{6} \times \frac{15}{6}}{\frac{15 \times 5}{6} + \frac{15}{6}} = \frac{\frac{15 \times 5 \times 15}{6 \times 6}}{\frac{75 + 15}{6}}$

$$= \frac{15 \times 5 \times 15}{6 \times 90} = \frac{25}{12} = 2.08 \Omega.$$

b) Across AC,

$$R_{\text{eff}} = \frac{\frac{15 \times 4}{6} \times \frac{15 \times 2}{6}}{\frac{15 \times 4}{6} + \frac{15 \times 2}{6}} = \frac{\frac{15 \times 4 \times 15 \times 2}{6 \times 6}}{\frac{60 + 30}{6}}$$

$$= \frac{15 \times 4 \times 15 \times 2}{6 \times 90} = \frac{10}{3} = 3.33 \Omega.$$

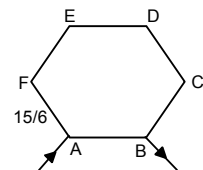

c) Across AD,

$$R_{\text{eff}} = \frac{\frac{15 \times 3}{6} \times \frac{15 \times 3}{6}}{\frac{15 \times 3}{6} + \frac{15 \times 3}{6}} = \frac{6 \times 6}{60 + 30}$$

$$= \frac{15 \times 3 \times 15 \times 3}{6 \times 90} = \frac{15}{4} = 3.75 \Omega.$$

32. a) When S is open

$$R_{\text{eq}} = (10 + 20) \Omega = 30 \Omega.$$

i = When S is closed,

$$R_{\text{eq}} = 10 \Omega$$

$$i = (3/10) \Omega = 0.3 \Omega.$$

33. a) Current through (1) 4 Ω resistor = 0

b) Current through (2) and (3)

$$\text{net } E = 4V - 2V = 2V$$

(2) and (3) are in series,

$$R_{\text{eff}} = 4 + 6 = 10 \Omega$$

$$i = 2/10 = 0.2 \text{ A}$$

Current through (2) and (3) are 0.2 A.

34. Let potential at the point be xV.

$$(30 - x) = 10 i_1$$

$$(x - 12) = 20 i_2$$

$$(x - 2) = 30 i_3$$

$$i_1 = i_2 + i_3$$

$$\Rightarrow \frac{30 - x}{10} = \frac{x - 12}{20} + \frac{x - 2}{30}$$

$$\Rightarrow 30 - x = \frac{x - 12}{2} + \frac{x - 2}{3}$$

$$\Rightarrow 30 - x = \frac{3x - 36 + 2x - 4}{6}$$

$$\Rightarrow 180 - 6x = 5x - 40$$

$$\Rightarrow 11x = 220 \Rightarrow x = 220 / 11 = 20 \text{ V.}$$

$$i_1 = \frac{30 - 20}{10} = 1 \text{ A}$$

$$i_2 = \frac{20 - 12}{20} = 0.4 \text{ A}$$

$$i_3 = \frac{20 - 2}{30} = \frac{6}{10} = 0.6 \text{ A.}$$

35. a) Potential difference between terminals of 'a' is 10 V.

$$i \text{ through } a = 10 / 10 = 1 \text{ A}$$

Potential different between terminals of b is 10 - 10 = 0 V

$$i \text{ through } b = 0/10 = 0 \text{ A}$$

b) Potential difference across 'a' is 10 V

$$i \text{ through } a = 10 / 10 = 1 \text{ A}$$

Potential different between terminals of b is 10 - 10 = 0 V

$$i \text{ through } b = 0/10 = 0 \text{ A}$$

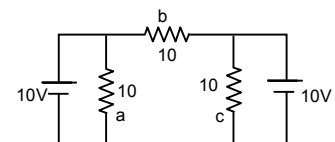
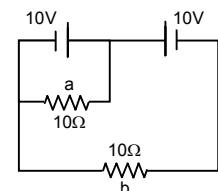
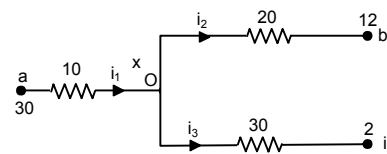
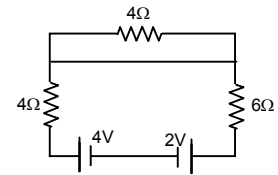
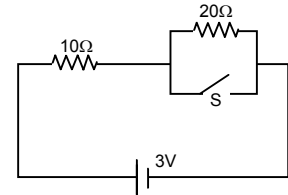

36. a) In circuit, AB ba A

$$E_2 + iR_2 + i_1R_3 = 0$$

In circuit, $i_1R_3 + E_1 - (i - i_1)R_1 = 0$

$$\Rightarrow i_1R_3 + E_1 - iR_1 + i_1R_1 = 0$$

$$[iR_2 + i_1R_3 = -E_2]R_1$$

$$[iR_2 - i_1(R_1 + R_3) = E_1] R_2$$

$$iR_2R_1 + i_1R_3R_1 = -E_2R_1$$

$$iR_2R_1 - i_1R_2(R_1 + R_3) = E_1 R_2$$

$$iR_3R_1 + i_1R_2R_1 + i_1R_2R_3 = E_1R_2 - E_2R_1$$

$$\Rightarrow i_1(R_3R_1 + R_2R_1 + R_2R_3) = E_1R_2 - E_2R_1$$

$$\Rightarrow i_1 = \frac{E_1R_2 - E_2R_1}{R_3R_1 + R_2R_1 + R_2R_3}$$

$$\Rightarrow \frac{E_1R_2R_3 - E_2R_1R_3}{R_3R_1 + R_2R_1 + R_2R_3} = \left(\frac{\frac{E_1}{R_1} - \frac{E_2}{R_2}}{\frac{1}{R_2} + \frac{1}{R_1} + \frac{1}{R_3}} \right)$$

b) \therefore Same as a

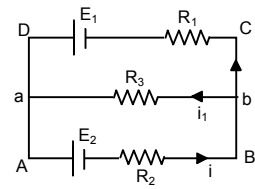
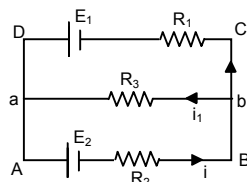
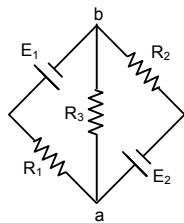

37. In circuit ABDCA,

$$i_1 + 2 - 3 + i = 0$$

$$\Rightarrow i + i_1 - 1 = 0 \quad \dots(1)$$

In circuit CFEDC,

$$(i - i_1) + 1 - 3 + i = 0$$

$$\Rightarrow 2i - i_1 - 2 = 0 \quad \dots(2)$$

From (1) and (2)

$$3i = 3 \Rightarrow i = 1 \text{ A}$$

$$i_1 = 1 - i = 0 \text{ A}$$

$$i - i_1 = 1 - 0 = 1 \text{ A}$$

Potential difference between A and B

$$= E - ir = 3 - 1.1 = 2 \text{ V.}$$

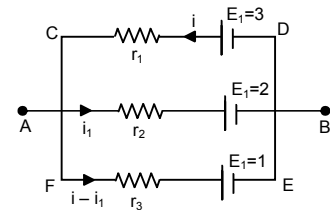

38. In the circuit ADCBA,

$$3i + 6i_1 - 4.5 = 0$$

In the circuit GEFCG,

$$3i + 6i_1 = 4.5 \quad = \quad 10i - 10i_1 - 6i_1 = -3$$

$$\Rightarrow [10i - 16i_1 = -3]3 \quad \dots(1)$$

$$[3i + 6i_1 = 4.5] 10 \quad \dots(2)$$

From (1) and (2)

$$-108 i_1 = -54$$

$$\Rightarrow i_1 = \frac{54}{108} = \frac{1}{2} = 0.5$$

$$3i + 6 \times \frac{1}{2} - 4.5 = 0$$

$$3i - 1.5 = 0 \Rightarrow i = 0.5.$$

Current through 10Ω resistor = 0 A.

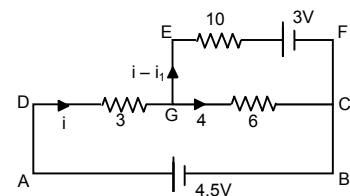

39. In AHGBA,

$$2 + (i - i_1) - 2 = 0$$

$$\Rightarrow i - i_1 = 0$$

In circuit CFEDC,

$$-(i_1 - i_2) + 2 + i_2 - 2 = 0$$

$$\Rightarrow i_2 - i_1 + i_2 = 0 \Rightarrow 2i_2 - i_1 = 0.$$

In circuit BGFCB,

$$-(i_1 - i_2) + 2 + (i_1 - i_2) - 2 = 0$$

$$\Rightarrow i_1 - i + i_1 - i_2 = 0 \quad \Rightarrow 2i_1 - i - i_2 = 0 \quad \dots(1)$$

$$\Rightarrow i_1 - (i - i_1) - i_2 = 0 \quad \Rightarrow i_1 - i_2 = 0 \quad \dots(2)$$

$$\therefore i_1 - i_2 = 0$$

From (1) and (2)

Current in the three resistors is 0.

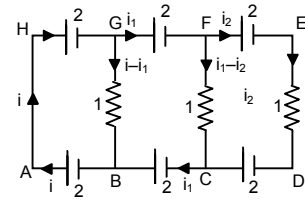

40.

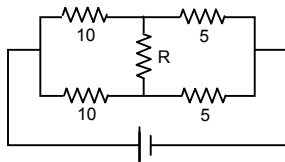

For an value of R, the current in the branch is 0.

41. a) $R_{\text{eff}} = \frac{(2r/2) \times r}{(2r/2) + r}$
 $= \frac{r^2}{2r} = \frac{r}{2}$

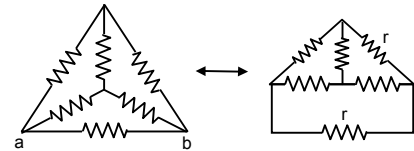

b) At 0 current coming to the junction is current going from BO = Current going along OE.

Current on CO = Current on OD

Thus it can be assumed that current coming in OC goes in OB.

Thus the figure becomes

$$\left[r + \left(\frac{2r \cdot r}{3r} \right) + r \right] = 2r + \frac{2r}{3} = \frac{8r}{3}$$

$$R_{\text{eff}} = \frac{(8r/6) \times 2r}{(8r/6) + 2r} = \frac{8r^2/3}{20r/6} = \frac{8r^2}{3} \times \frac{6}{20} = \frac{8r}{10} = 4r.$$

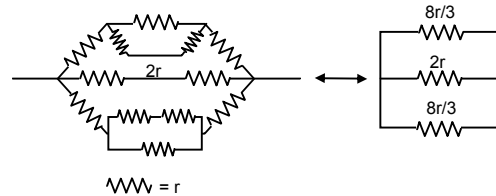
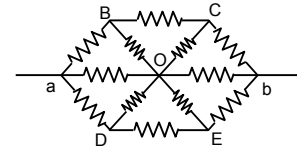

42.

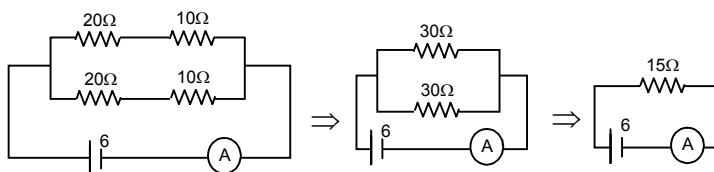
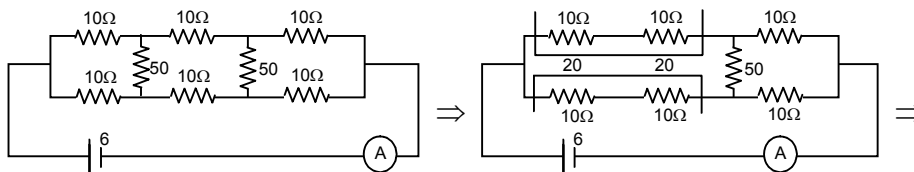

$$I = \frac{6}{15} = \frac{2}{5} = 0.4 \text{ A.}$$

43. a) Applying Kirchoff's law,

$$10i - 6 + 5i - 12 = 0$$

$$\Rightarrow 10i + 5i = 18$$

$$\Rightarrow 15i = 18$$

$$\Rightarrow i = \frac{18}{15} = \frac{6}{5} = 1.2 \text{ A.}$$

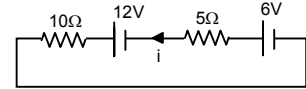

b) Potential drop across 5 Ω resistor,

$$i 5 = 1.2 \times 5 \text{ V} = 6 \text{ V}$$

c) Potential drop across 10 Ω resistor

$$i 10 = 1.2 \times 10 \text{ V} = 12 \text{ V}$$

d) $10i - 6 + 5i - 12 = 0$

$$\Rightarrow 10i + 5i = 18$$

$$\Rightarrow 15i = 18$$

$$\Rightarrow i = \frac{18}{15} = \frac{6}{5} = 1.2 \text{ A.}$$

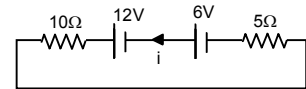

Potential drop across 5 Ω resistor = 6 V

Potential drop across 10 Ω resistor = 12 V

44. Taking circuit ABHGA,

$$\frac{i}{3r} + \frac{i}{6r} + \frac{i}{3r} = V$$

$$\Rightarrow \left(\frac{2i}{3} + \frac{i}{6} \right) r = V$$

$$\Rightarrow V = \frac{5i}{6} r$$

$$\Rightarrow R_{\text{eff}} = \frac{V}{i} = \frac{5}{6} r$$

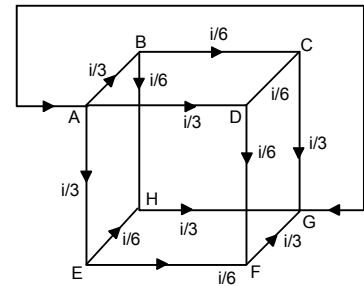

$$45. R_{\text{eff}} = \frac{\left(\frac{2r}{3} + r \right) r}{\left(\frac{2r}{3} + r + r \right)} = \frac{5r}{8}$$

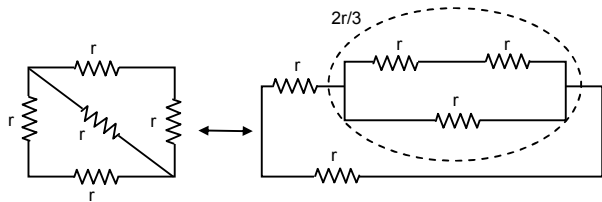

$$R_{\text{eff}} = \frac{r}{3} + r = \frac{4r}{3}$$

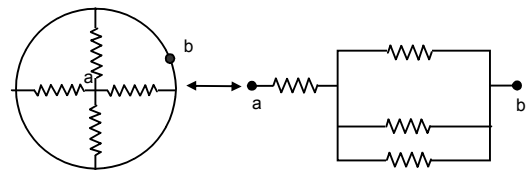

$$R_{\text{eff}} = \frac{2r}{2} = r$$

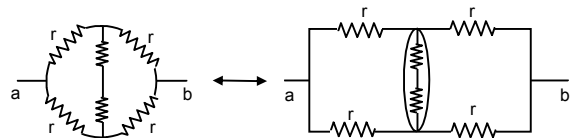

$$R_{\text{eff}} = \frac{r}{4}$$

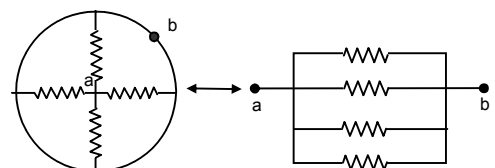

$$R_{\text{eff}} = r$$

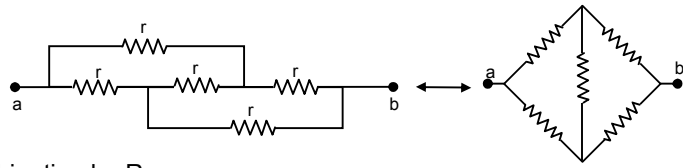

46. a) Let the equivalent resistance of the combination be R.

$$\left(\frac{2R}{R+2}\right) + 1 = R$$

$$\Rightarrow \frac{2R + R + 2}{R + 2} = R \Rightarrow 3R + 2 = R^2 + 2R$$

$$\Rightarrow R^2 - R - 2 = 0$$

$$\Rightarrow R = \frac{+1 \pm \sqrt{1 + 4 \cdot 1 \cdot 2}}{2 \cdot 1} = \frac{1 \pm \sqrt{9}}{2} = \frac{1 + 3}{2} = 2 \Omega.$$

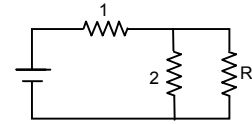
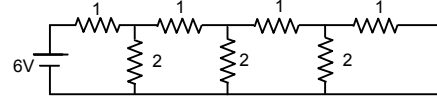

b) Total current sent by battery = $\frac{6}{R_{\text{eff}}} = \frac{6}{2} = 3$

Potential between A and B

$$3 \cdot 1 + 2 \cdot i = 6$$

$$\Rightarrow 3 + 2i = 6 \Rightarrow 2i = 3$$

$$\Rightarrow i = 1.5 \text{ a}$$

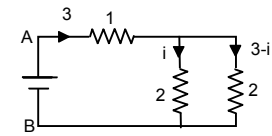

47. a) In circuit ABFGA,

$$i_1 \cdot 50 + 2i + i - 4.3 = 0$$

$$\Rightarrow 50i_1 + 3i = 4.3 \quad \dots(1)$$

In circuit BEDCB,

$$50i_1 - (i - i_1)200 = 0$$

$$\Rightarrow 50i_1 - 200i + 200i_1 = 0$$

$$\Rightarrow 250i_1 - 200i = 0$$

$$\Rightarrow 50i_1 - 40i = 0 \quad \dots(2)$$

From (1) and (2)

$$43i = 4.3 \Rightarrow i = 0.1$$

$$5i_1 = 4 \times i = 4 \times 0.1 \Rightarrow i_1 = \frac{4 \times 0.1}{5} = 0.08 \text{ A.}$$

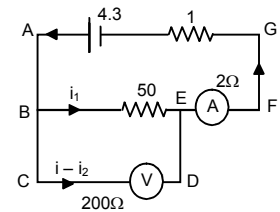

Ammeter reads a current = $i = 0.1 \text{ A.}$

Voltmeter reads a potential difference equal to $i_1 \times 50 = 0.08 \times 50 = 4 \text{ V.}$

b) In circuit ABEFA,

$$50i_1 + 2i_1 + 1i - 4.3 = 0$$

$$\Rightarrow 52i_1 + i = 4.3$$

$$\Rightarrow 200 \times 52i_1 + 200i = 4.3 \times 200 \quad \dots(1)$$

In circuit BCDEB,

$$(i - i_1)200 - i_1 \cdot 2 - i_1 \cdot 50 = 0$$

$$\Rightarrow 200i - 200i_1 - 2i_1 - 50i_1 = 0$$

$$\Rightarrow 200i - 252i_1 = 0 \quad \dots(2)$$

From (1) and (2)

$$i_1(10652) = 4.3 \times 2 \times 100$$

$$\Rightarrow i_1 = \frac{4.3 \times 2 \times 100}{10652} = 0.08$$

$$i = 4.3 - 52 \times 0.08 = 0.14$$

Reading of the ammeter = 0.08 a

Reading of the voltmeter = $(i - i_1)200 = (0.14 - 0.08) \times 200 = 12 \text{ V.}$

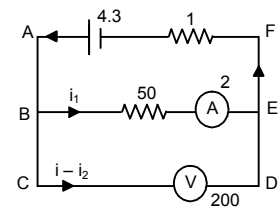

48. a) $R_{\text{eff}} = \frac{100 \times 400}{500} + 200 = 280$

$i = \frac{84}{280} = 0.3$

$100i = (0.3 - i) 400$

$\Rightarrow i = 1.2 - 4i$

$\Rightarrow 5i = 1.2 \Rightarrow i = 0.24.$

Voltage measured by the voltmeter = $\frac{0.24 \times 100}{24V}$

b) If voltmeter is not connected

$R_{\text{eff}} = (200 + 100) = 300 \Omega$

$i = \frac{84}{300} = 0.28 \text{ A}$

Voltage across $100 \Omega = (0.28 \times 100) = 28 \text{ V}.$

49. Let resistance of the voltmeter be $R \Omega.$

$R_1 = \frac{50R}{50 + R}, R_2 = 24$

Both are in series.

$30 = V_1 + V_2$

$\Rightarrow 30 = iR_1 + iR_2$

$\Rightarrow 30 - iR_2 = iR_1$

$\Rightarrow iR_1 = 30 - \frac{30}{R_1 + R_2} R_2$

$\Rightarrow V_1 = 30 \left(1 - \frac{R_2}{R_1 + R_2} \right)$

$\Rightarrow V_1 = 30 \left(\frac{R_1}{R_1 + R_2} \right)$

$\Rightarrow 18 = 30 \left(\frac{50R}{50 + R \left(\frac{50R}{50 + R} + 24 \right)} \right)$

$\Rightarrow 18 = 30 \left(\frac{50R \times (50 + R)}{(50 + R) + (50R + 24)(50 + R)} \right) = \frac{30(50R)}{50R + 1200 + 24R}$

$\Rightarrow 18 = \frac{30 \times 50 \times R}{74R + 1200} = 18(74R + 1200) = 1500 R$

$\Rightarrow 1332R + 21600 = 1500 R \Rightarrow 21600 = 1.68 R$

$\Rightarrow R = 21600 / 168 = 128.57.$

50. Full deflection current = $10 \text{ mA} = (10 \times 10^{-3}) \text{ A}$

$R_{\text{eff}} = (575 + 25) \Omega = 600 \Omega$

$V = R_{\text{eff}} \times i = 600 \times 10 \times 10^{-3} = 6 \text{ V}.$

51. $G = 25 \Omega, I_g = 1 \text{ ma}, I = 2 \text{ A}, S = ?$

Potential across A B is same

$25 \times 10^{-3} = (2 - 10^{-3}) S$

$\Rightarrow S = \frac{25 \times 10^{-3}}{2 - 10^{-3}} = \frac{25 \times 10^{-3}}{1.999}$

$= 12.5 \times 10^{-3} = 1.25 \times 10^{-2}.$

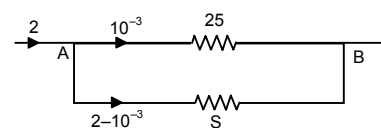
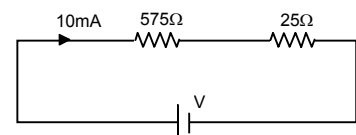
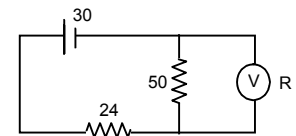
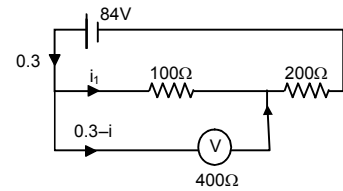

52. $R_{\text{eff}} = (1150 + 50)\Omega = 1200 \Omega$

$i = (12 / 1200)\text{A} = 0.01 \text{ A.}$

(The resistor of 50Ω can tolerate)

Let R be the resistance of sheet used.

The potential across both the resistors is same.

$0.01 \times 50 = 1.99 \times R$

$\Rightarrow R = \frac{0.01 \times 50}{1.99} = \frac{50}{199} = 0.251 \Omega.$

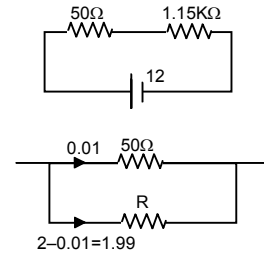

53. If the wire is connected to the potentiometer wire so that $\frac{R_{AD}}{R_{DB}} = \frac{8}{12}$, then according to wheat stone's

bridge no current will flow through galvanometer.

$\frac{R_{AB}}{R_{DB}} = \frac{L_{AB}}{L_B} = \frac{8}{12} = \frac{2}{3}$ (Acc. To principle of potentiometer).

$I_{AB} + I_{DB} = 40 \text{ cm}$
 $\Rightarrow I_{DB} \frac{2}{3} + I_{DB} = 40 \text{ cm}$

$\Rightarrow (\frac{2}{3} + 1)I_{DB} = 40 \text{ cm}$

$\Rightarrow \frac{5}{3} I_{DB} = 40 \Rightarrow L_{DB} = \frac{40 \times 3}{5} = 24 \text{ cm.}$

$L_{AB} = (40 - 24) \text{ cm} = 16 \text{ cm.}$

54. The deflections does not occur in galvanometer if the condition is a balanced wheatstone bridge.

Let Resistance / unit length = r .

Resistance of 30 m length = $30r$.

Resistance of 20 m length = $20r$.

For balanced wheatstones bridge = $\frac{6}{R} = \frac{30r}{20r}$

$\Rightarrow 30 R = 20 \times 6 \Rightarrow R = \frac{20 \times 6}{30} = 4 \Omega.$

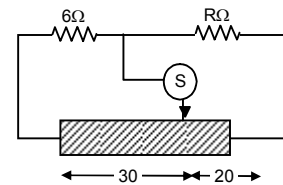
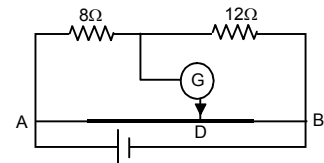

55. a) Potential difference between A and B is 6 V.

B is at 0 potential.

Thus potential of A point is 6 V.

The potential difference between Ac is 4 V.

$V_A - V_C = 0.4$

$V_C = V_A - 4 = 6 - 4 = 2 \text{ V.}$

b) The potential at D = 2V, $V_{AD} = 4 \text{ V}$; $V_{BD} = 0\text{V}$

Current through the resistors R_1 and R_2 are equal.

Thus, $\frac{4}{R_1} = \frac{2}{R_2}$

$\Rightarrow \frac{R_1}{R_2} = 2$

$\Rightarrow \frac{l_1}{l_2} = 2$ (Acc. to the law of potentiometer)

$l_1 + l_2 = 100 \text{ cm}$

$\Rightarrow l_1 + \frac{l_1}{2} = 100 \text{ cm} \Rightarrow \frac{3l_1}{2} = 100 \text{ cm}$

$\Rightarrow l_1 = \frac{200}{3} \text{ cm} = 66.67 \text{ cm.}$

$AD = 66.67 \text{ cm}$

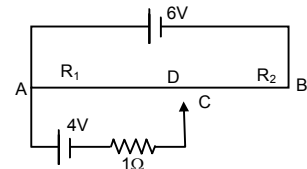

- c) When the points C and D are connected by a wire current flowing through it is 0 since the points are equipotential.
 d) Potential at A = 6 v
 Potential at C = 6 - 7.5 = -1.5 V
 The potential at B = 0 and towards A potential increases.
 Thus -ve potential point does not come within the wire.

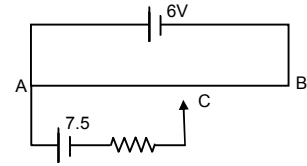

56. Resistance per unit length = $\frac{15r}{6}$

For length x, $R_x = \frac{15r}{6} \times x$

a) For the loop PASQ $(i_1 + i_2) \frac{15}{6} rx + \frac{15}{6} (6 - x)i_1 + i_1 R = E \dots(1)$

For the loop AWTM, $-i_2 \cdot R - \frac{15}{6} rx (i_1 + i_2) = E/2$

$\Rightarrow i_2 R + \frac{15}{6} r \times (i_1 + i_2) = E/2 \dots(2)$

For zero deflection galvanometer $i_2 = 0 \Rightarrow \frac{15}{6} rx \cdot i_1 = E/2 = i_1 = \frac{E}{5x \cdot r}$

Putting $i_1 = \frac{E}{5x \cdot r}$ and $i_2 = 0$ in equation (1), we get $x = 320$ cm.

b) Putting $x = 5.6$ and solving equation (1) and (2) we get $i_2 = \frac{3E}{22r}$.

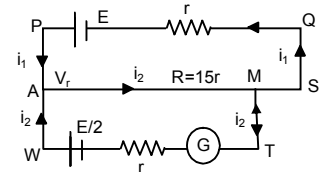

57. In steady stage condition no current flows through the capacitor.

$R_{\text{eff}} = 10 + 20 = 30 \Omega$

$i = \frac{2}{30} = \frac{1}{15} \text{ A}$

Voltage drop across 10 Ω resistor = $i \times R$

$= \frac{1}{15} \times 10 = \frac{10}{15} = \frac{2}{3} \text{ V}$

Charge stored on the capacitor (Q) = CV

$= 6 \times 10^{-6} \times 2/3 = 4 \times 10^{-6} \text{ C} = 4 \mu\text{C}$.

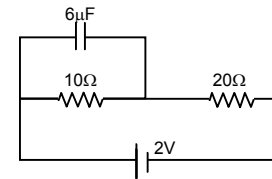

58. Taking circuit, ABCDA,

$10i + 20(i - i_1) - 5 = 0$

$\Rightarrow 10i + 20i - 20i_1 - 5 = 0$

$\Rightarrow 30i - 20i_1 - 5 = 0 \dots(1)$

Taking circuit ABFEA,

$20(i - i_1) - 5 - 10i_1 = 0$

$\Rightarrow 10i - 20i_1 - 10i_1 - 5 = 0$

$\Rightarrow 20i - 30i_1 - 5 = 0 \dots(2)$

From (1) and (2)

$(90 - 40)i_1 = 0$

$\Rightarrow i_1 = 0$

$30i - 5 = 0$

$\Rightarrow i = 5/30 = 0.16 \text{ A}$

Current through 20 Ω is 0.16 A.

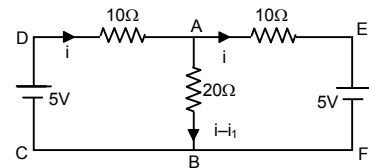

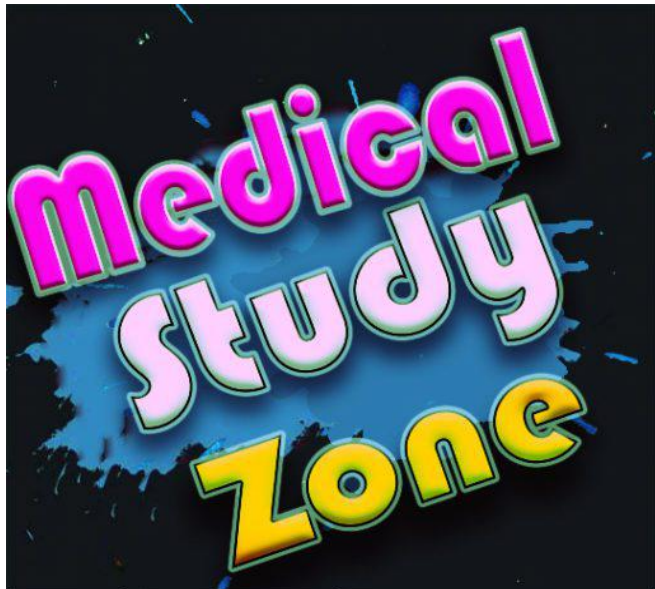

Medicalstudyzone.com

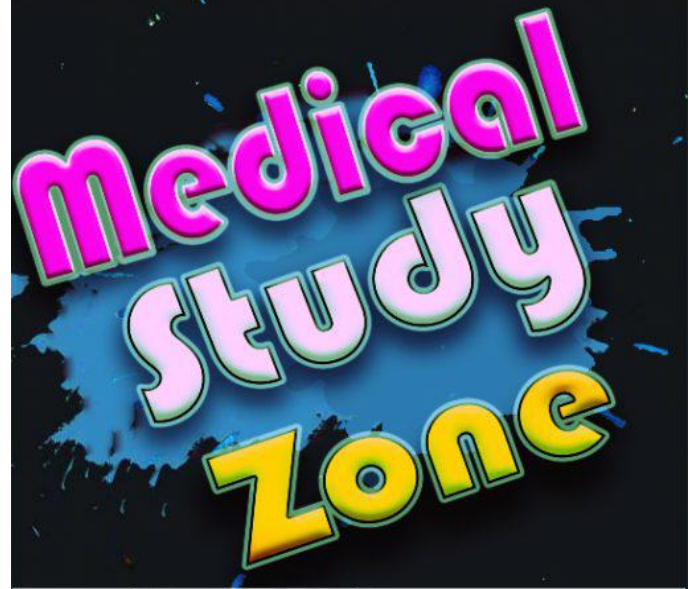

Medicalstudyzone.com

This PDF was created and uploaded by www.medicalstudyzone.com which is one the biggest free resources platform for medical students and healthcare professionals. You can access all medical Video Lectures, Books in PDF Format or kindle Edition, Paid Medical Apps and Softwares, Qbanks, Audio Lectures And Much More Absolutely for Free By visiting our Website <https://medicalstudyzone.com> all stuff are free with no cost at all.

Furthermore You can also request a specific Book In PDF Format OR Medical Video Lectures.

59. At steady state no current flows through the capacitor.

$$R_{eq} = \frac{3 \times 6}{3 + 6} = 2 \Omega.$$

$$i = \frac{6}{2} = 3.$$

Since current is divided in the inverse ratio of the resistance in each branch, thus 2Ω will pass through 1, 2Ω branch and 1 through 3, 3Ω branch

$$V_{AB} = 2 \times 1 = 2V.$$

$$Q \text{ on } 1 \mu F \text{ capacitor} = 2 \times 1 \mu C = 2 \mu C$$

$$V_{BC} = 2 \times 2 = 4V.$$

$$Q \text{ on } 2 \mu F \text{ capacitor} = 4 \times 2 \mu C = 8 \mu C$$

$$V_{DE} = 1 \times 3 = 2V.$$

$$Q \text{ on } 4 \mu F \text{ capacitor} = 3 \times 4 \mu C = 12 \mu C$$

$$V_{FE} = 3 \times 1 = V.$$

$$Q \text{ across } 3 \mu F \text{ capacitor} = 3 \times 3 \mu C = 9 \mu C.$$

60. $C_{eq} = [(3 \mu f \text{ p } 3 \mu f) \text{ s } (1 \mu f \text{ p } 1 \mu f)] \text{ p } (1 \mu f)$
 $= [(3 + 3)\mu f \text{ s } (2\mu f)] \text{ p } 1 \mu f$
 $= 3/2 + 1 = 5/2 \mu f$

$$V = 100 \text{ V}$$

$$Q = CV = 5/2 \times 100 = 250 \mu C$$

$$\text{Charge stored across } 1 \mu f \text{ capacitor} = 100 \mu C$$

$$C_{eq} \text{ between A and B is } 6 \mu f = C$$

$$\text{Potential drop across AB} = V = Q/C = 25 \text{ V}$$

$$\text{Potential drop across BC} = 75 \text{ V.}$$

61. a) Potential difference = E across resistor
 b) Current in the circuit = E/R
 c) Pd. Across capacitor = E/R

$$d) \text{ Energy stored in capacitor} = \frac{1}{2} CE^2$$

$$e) \text{ Power delivered by battery} = E \times I = E \times \frac{E}{R} = \frac{E^2}{R}$$

$$f) \text{ Power converted to heat} = \frac{E^2}{R}$$

62. $A = 20 \text{ cm}^2 = 20 \times 10^{-4} \text{ m}^2$

$$d = 1 \text{ mm} = 1 \times 10^{-3} \text{ m}; R = 10 \text{ K}\Omega$$

$$C = \frac{\epsilon_0 A}{d} = \frac{8.85 \times 10^{-12} \times 20 \times 10^{-4}}{1 \times 10^{-3}}$$

$$= \frac{8.85 \times 10^{-12} \times 2 \times 10^{-3}}{10^{-3}} = 17.7 \times 10^{-2} \text{ Farad.}$$

$$\text{Time constant} = CR = 17.7 \times 10^{-2} \times 10 \times 10^3$$

$$= 17.7 \times 10^{-8} = 0.177 \times 10^{-6} \text{ s} = 0.18 \mu s.$$

63. $C = 10 \mu F = 10^{-5} \text{ F}$, emf = 2 V

$$t = 50 \text{ ms} = 5 \times 10^{-2} \text{ s}, q = Q(1 - e^{-t/RC})$$

$$Q = CV = 10^{-5} \times 2$$

$$q = 12.6 \times 10^{-6} \text{ F}$$

$$\Rightarrow 12.6 \times 10^{-6} = 2 \times 10^{-5} (1 - e^{-5 \times 10^{-2} / R \times 10^{-5}})$$

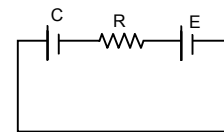
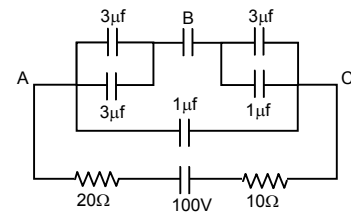
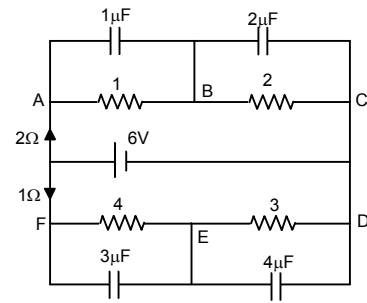

$$\Rightarrow \frac{12.6 \times 10^{-6}}{2 \times 10^{-5}} = 1 - e^{-5 \times 10^{-2} / R \times 10^{-5}}$$

$$\Rightarrow 1 - 0.63 = e^{-5 \times 10^3 / R}$$

$$\Rightarrow \frac{-5000}{R} = \ln 0.37$$

$$\Rightarrow R = \frac{5000}{0.9942} = 5028 \Omega = 5.028 \times 10^3 \Omega = 5 \text{ K}\Omega.$$

64. $C = 20 \times 10^{-6} \text{ F}$, $E = 6 \text{ V}$, $R = 100 \Omega$

$$t = 2 \times 10^{-3} \text{ sec}$$

$$q = EC(1 - e^{-t/RC})$$

$$= 6 \times 20 \times 10^{-6} \left(1 - e^{-\frac{2 \times 10^{-3}}{100 \times 20 \times 10^{-6}}}\right)$$

$$= 12 \times 10^{-5} (1 - e^{-1}) = 7.12 \times 0.63 \times 10^{-5} = 7.56 \times 10^{-5}$$

$$= 75.6 \times 10^{-6} = 76 \mu\text{c}.$$

65. $C = 10 \mu\text{F}$, $Q = 60 \mu\text{C}$, $R = 10 \Omega$

a) at $t = 0$, $q = 60 \mu\text{c}$

b) at $t = 30 \mu\text{s}$, $q = Qe^{-t/RC}$
 $= 60 \times 10^{-6} \times e^{-0.3} = 44 \mu\text{c}$

c) at $t = 120 \mu\text{s}$, $q = 60 \times 10^{-6} \times e^{-1.2} = 18 \mu\text{c}$

d) at $t = 1.0 \text{ ms}$, $q = 60 \times 10^{-6} \times e^{-10} = 0.00272 = 0.003 \mu\text{c}.$

66. $C = 8 \mu\text{F}$, $E = 6\text{V}$, $R = 24 \Omega$

a) $I = \frac{V}{R} = \frac{6}{24} = 0.25\text{A}$

b) $q = Q(1 - e^{-t/RC})$
 $= (8 \times 10^{-6} \times 6) [1 - e^{-1}] = 48 \times 10^{-6} \times 0.63 = 3.024 \times 10^{-5}$

$$V = \frac{Q}{C} = \frac{3.024 \times 10^{-5}}{8 \times 10^{-6}} = 3.78$$

$$E = V + iR$$

$$\Rightarrow 6 = 3.78 + i24$$

$$\Rightarrow i = 0.09 \text{ A}$$

67. $A = 40 \text{ m}^2 = 40 \times 10^{-4}$

$$d = 0.1 \text{ mm} = 1 \times 10^{-4} \text{ m}$$

$$R = 16 \Omega ; \text{emf} = 2 \text{ V}$$

$$C = \frac{E_0 A}{d} = \frac{8.85 \times 10^{-12} \times 40 \times 10^{-4}}{1 \times 10^{-4}} = 35.4 \times 10^{-11} \text{ F}$$

$$\text{Now, } E = \frac{Q}{AE_0} (1 - e^{-t/RC}) = \frac{CV}{AE_0} (1 - e^{-t/RC})$$

$$= \frac{35.4 \times 10^{-11} \times 2}{40 \times 10^{-4} \times 8.85 \times 10^{-12}} (1 - e^{-1.76})$$

$$= 1.655 \times 10^{-4} = 1.7 \times 10^{-4} \text{ V/m}.$$

68. $A = 20 \text{ cm}^2$, $d = 1 \text{ mm}$, $K = 5$, $e = 6 \text{ V}$

$$R = 100 \times 10^3 \Omega, t = 8.9 \times 10^{-5} \text{ s}$$

$$C = \frac{KE_0 A}{d} = \frac{5 \times 8.85 \times 10^{-12} \times 20 \times 10^{-4}}{1 \times 10^{-3}}$$

$$= \frac{10 \times 8.85 \times 10^{-3} \times 10^{-12}}{10^{-3}} = 88.5 \times 10^{-12}$$

$$q = EC(1 - e^{-t/RC})$$

$$= 6 \times 88.5 \times 10^{-12} \left(1 - e^{\frac{-89 \times 10^{-6}}{88.5 \times 10^{-12} \times 10^4}} \right) = 530.97$$

$$\text{Energy} = \frac{1}{2} \times \frac{500.97 \times 530}{88.5 \times 10^{-12}}$$

$$= \frac{530.97 \times 530.97}{88.5 \times 2} \times 10^{12}$$

69. Time constant $RC = 1 \times 10^6 \times 100 \times 10^6 = 100 \text{ sec}$

a) $q = VC(1 - e^{-t/CR})$
 $I = \text{Current} = dq/dt = VC \cdot (-) e^{-t/RC} \cdot (-1)/RC$
 $= \frac{V}{R} e^{-t/RC} = \frac{V}{R \cdot e^{t/RC}} = \frac{24}{10^6} \cdot \frac{1}{e^{t/100}}$
 $= 24 \times 10^{-6} \cdot 1/e^{t/100}$

$t = 10 \text{ min}, 600 \text{ sec.}$

$Q = 24 \times 10^{-6} \times (1 - e^{-6}) = 23.99 \times 10^{-4}$

$I = \frac{24}{10^6} \cdot \frac{1}{e^6} = 5.9 \times 10^{-8} \text{ Amp.}$

b) $q = VC(1 - e^{-t/CR})$

70. $Q/2 = Q(1 - e^{-t/CR})$

$\Rightarrow \frac{1}{2} = (1 - e^{-t/CR})$

$\Rightarrow e^{-t/CR} = 1/2$

$\Rightarrow \frac{t}{RC} = \log 2 \Rightarrow n = 0.69.$

71. $q = Qe^{-t/RC}$

$q = 0.1 \% Q \quad RC \Rightarrow \text{Time constant}$

$= 1 \times 10^{-3} Q$

So, $1 \times 10^{-3} Q = Q \times e^{-t/RC}$

$\Rightarrow e^{-t/RC} = 10^{-3}$

$\Rightarrow t/RC = -(-6.9) = 6.9$

72. $q = Q(1 - e^{-t})$

$\frac{1}{2} \frac{Q^2}{C} = \text{Initial value}; \quad \frac{1}{2} \frac{q^2}{c} = \text{Final value}$

$\frac{1}{2} \frac{q^2}{c} \times 2 = \frac{1}{2} \frac{Q^2}{C}$

$\Rightarrow q^2 = \frac{Q^2}{2} \Rightarrow q = \frac{Q}{\sqrt{2}}$

$\frac{Q}{\sqrt{2}} = Q(1 - e^{-n})$

$\Rightarrow \frac{1}{\sqrt{2}} = 1 - e^{-n} \Rightarrow e^{-n} = 1 - \frac{1}{\sqrt{2}}$

$\Rightarrow n = \log \left(\frac{\sqrt{2}}{\sqrt{2}-1} \right) = 1.22$

73. Power = $CV^2 = Q \times V$

Now, $\frac{QV}{2} = QV \times e^{-t/RC}$

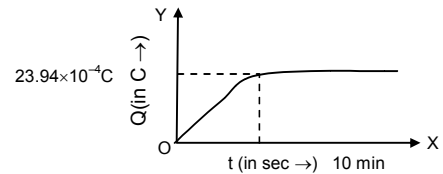
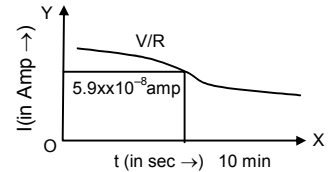

$$\Rightarrow \frac{1}{2} = e^{-t/RC}$$

$$\Rightarrow \frac{t}{RC} = -\ln 0.5$$

$$\Rightarrow -(-0.69) = 0.69$$

74. Let at any time t , $q = EC(1 - e^{-t/CR})$

$$E = \text{Energy stored} = \frac{q^2}{2c} = \frac{E^2 C^2}{2c} (1 - e^{-t/CR})^2 = \frac{E^2 C}{2} (1 - e^{-t/CR})^2$$

$$R = \text{rate of energy stored} = \frac{dE}{dt} = \frac{-E^2 C}{2} \left(\frac{-1}{RC} \right)^2 (1 - e^{-t/CR}) e^{-t/CR} = \frac{E^2}{CR} \cdot e^{-t/CR} (1 - e^{-t/CR})$$

$$\frac{dR}{dt} = \frac{E^2}{2R} \left[\frac{-1}{RC} e^{-t/CR} \cdot (1 - e^{-t/CR}) + (-) \cdot e^{-t/CR(1-1/RC)} \cdot e^{-t/CR} \right]$$

$$\frac{E^2}{2R} = \left(\frac{-e^{-t/CR}}{RC} + \frac{e^{-2t/CR}}{RC} + \frac{1}{RC} \cdot e^{-2t/CR} \right) = \frac{E^2}{2R} \left(\frac{2}{RC} \cdot e^{-2t/CR} - \frac{e^{-t/CR}}{RC} \right) \quad \dots(1)$$

$$\text{For } R_{\max} \frac{dR}{dt} = 0 \Rightarrow 2 \cdot e^{-t/RC} - 1 = 0 \Rightarrow e^{-t/RC} = 1/2$$

$$\Rightarrow -t/RC = -\ln 2 \Rightarrow t = RC \ln 2$$

$$\therefore \text{Putting } t = RC \ln 2 \text{ in equation (1) We get } \frac{dR}{dt} = \frac{E^2}{4R}$$

75. $C = 12.0 \mu\text{F} = 12 \times 10^{-6}$

$$\text{emf} = 6.00 \text{ V}, R = 1 \Omega$$

$$t = 12 \mu\text{s}, i = i_0 e^{-t/RC}$$

$$= \frac{CV}{T} \times e^{-t/RC} = \frac{12 \times 10^{-6} \times 6}{12 \times 10^{-6}} \times e^{-1}$$

$$= 2.207 = 2.1 \text{ A}$$

b) Power delivered by battery

$$\text{We known, } V = V_0 e^{-t/RC} \quad (\text{where } V \text{ and } V_0 \text{ are potential VI})$$

$$VI = V_0 I e^{-t/RC}$$

$$\Rightarrow VI = V_0 I \times e^{-1} = 6 \times 6 \times e^{-1} = 13.24 \text{ W}$$

$$\text{c) } U = \frac{CV^2}{T} (e^{-t/RC})^2 \quad \left[\frac{CV^2}{T} = \text{energy drawing per unit time} \right]$$

$$= \frac{12 \times 10^{-6} \times 36}{12 \times 10^{-6}} \times (e^{-1})^2 = 4.872.$$

76. Energy stored at a part time in discharging = $\frac{1}{2} CV^2 (e^{-t/RC})^2$

Heat dissipated at any time

$$= (\text{Energy stored at } t = 0) - (\text{Energy stored at time } t)$$

$$= \frac{1}{2} CV^2 - \frac{1}{2} CV^2 (-e^{-1})^2 = \frac{1}{2} CV^2 (1 - e^{-2})$$

$$77. \int i^2 R dt = \int i_0^2 R e^{-2t/RC} dt = i_0^2 R \int e^{-2t/RC} dt$$

$$= i_0^2 R (-RC/2) e^{-2t/RC} = \frac{1}{2} C i_0^2 R^2 e^{-2t/RC} = \frac{1}{2} CV^2 \quad (\text{Proved}).$$

78. Equation of discharging capacitor

$$= q_0 e^{-t/RC} = \frac{K \epsilon_0 AV}{d} e^{-\frac{1}{(\rho d K \epsilon_0 A)/Ad} t} = \frac{K \epsilon_0 AV}{d} e^{-t/\rho K \epsilon_0}$$

$$\therefore \tau = \rho K \epsilon_0$$

\therefore Time constant is $\rho K \epsilon_0$ is independent of plate area or separation between the plate.

79. $q = q_0(1 - e^{-t/RC})$

$$= 25(2 + 2) \times 10^{-6} \left(1 - e^{\frac{-0.2 \times 10^{-3}}{25 \times 4 \times 10^{-6}}}\right)$$

$$= 24 \times 10^{-6} (1 - e^{-2}) = 20.75$$

Charge on each capacitor = $20.75/2 = 10.3$

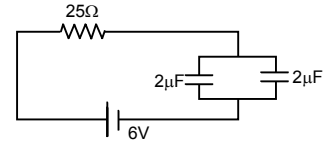

80. In steady state condition, no current passes through the 25 μF capacitor,

∴ Net resistance = $\frac{10\Omega}{2} = 5\Omega$.

Net current = $\frac{12}{5}$

Potential difference across the capacitor = 5

Potential difference across the 10 Ω resistor

= $12/5 \times 10 = 24$ V

$$q = Q(e^{-t/RC}) = V \times C(e^{-t/RC}) = 24 \times 25 \times 10^{-6} [e^{-1 \times 10^{-3} / 10 \times 25 \times 10^{-4}}]$$

$$= 24 \times 25 \times 10^{-6} e^{-4} = 24 \times 25 \times 10^{-6} \times 0.0183 = 10.9 \times 10^{-6} \text{ C}$$

Charge given by the capacitor after time t.

Current in the 10 Ω resistor = $\frac{10.9 \times 10^{-6} \text{ C}}{1 \times 10^{-3} \text{ sec}} = 11 \text{ mA}$.

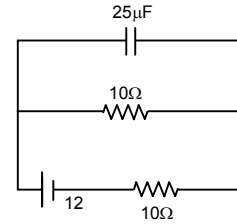

81. $C = 100 \mu\text{F}$, $\text{emf} = 6 \text{ V}$, $R = 20 \text{ K}\Omega$, $t = 4 \text{ S}$.

Charging : $Q = CV(1 - e^{-t/RC})$ $\left[\frac{-t}{RC} = \frac{4}{2 \times 10^4 \times 10^{-4}}\right]$

= $6 \times 10^{-4} (1 - e^{-2}) = 5.187 \times 10^{-4} \text{ C} = Q$

Discharging : $q = Q(e^{-t/RC}) = 5.184 \times 10^{-4} \times e^{-2}$
 = $0.7 \times 10^{-4} \text{ C} = 70 \mu\text{c}$.

82. $C_{\text{eff}} = \frac{C_1 C_2}{C_1 + C_2}$

$Q = C_{\text{eff}} E(1 - e^{-t/RC}) = \frac{C_1 C_2}{C_1 + C_2} E(1 - e^{-t/RC})$

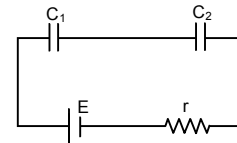

83. Let after time t charge on plate B is +Q.

Hence charge on plate A is Q - q.

$V_A = \frac{Q - q}{C}$, $V_B = \frac{q}{C}$

$V_A - V_B = \frac{Q - q}{C} - \frac{q}{C} = \frac{Q - 2q}{C}$

Current = $\frac{V_A - V_B}{R} = \frac{Q - 2q}{CR}$

Current = $\frac{dq}{dt} = \frac{Q - 2q}{CR}$

$\Rightarrow \frac{dq}{Q - 2q} = \frac{1}{RC} \cdot dt \Rightarrow \int_0^q \frac{dq}{Q - 2q} = \frac{1}{RC} \cdot \int_0^t dt$

$\Rightarrow -\frac{1}{2} [\ln(Q - 2q) - \ln Q] = \frac{1}{RC} \cdot t \Rightarrow \ln \frac{Q - 2q}{Q} = \frac{-2}{RC} \cdot t$

$\Rightarrow Q - 2q = Q e^{-2t/RC} \Rightarrow 2q = Q(1 - e^{-2t/RC})$

$\Rightarrow q = \frac{Q}{2} (1 - e^{-2t/RC})$

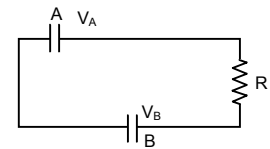

84. The capacitor is given a charge Q. It will discharge and the capacitor will be charged up when connected with battery.

Net charge at time t = $Qe^{-t/RC} + Q(1 - e^{-t/RC})$.

CHAPTER – 33
THERMAL AND CHEMICAL EFFECTS OF ELECTRIC CURRENT

1. $i = 2 \text{ A}$, $r = 25 \Omega$,
 $t = 1 \text{ min} = 60 \text{ sec}$
 Heat developed $= i^2 RT = 2 \times 2 \times 25 \times 60 = 6000 \text{ J}$

2. $R = 100 \Omega$, $E = 6 \text{ v}$
 Heat capacity of the coil $= 4 \text{ J/k}$ $\Delta T = 15^\circ\text{c}$

Heat liberate $\Rightarrow \frac{E^2}{Rt} = 4 \text{ J/K} \times 15$

$\Rightarrow \frac{6 \times 6}{100} \times t = 60 \Rightarrow t = 166.67 \text{ sec} = 2.8 \text{ min}$

3. (a) The power consumed by a coil of resistance R when connected across a supply v is $P = \frac{v^2}{R}$

The resistance of the heater coil is, therefore $R = \frac{v^2}{P} = \frac{(250)^2}{500} = 125 \Omega$

(b) If $P = 1000 \text{ w}$ then $R = \frac{v^2}{P} = \frac{(250)^2}{1000} = 62.5 \Omega$

4. $f = 1 \times 10^{-6} \Omega\text{m}$ $P = 500 \text{ W}$ $E = 250 \text{ v}$

(a) $R = \frac{V^2}{P} = \frac{250 \times 250}{500} = 125 \Omega$

(b) $A = 0.5 \text{ mm}^2 = 0.5 \times 10^{-6} \text{ m}^2 = 5 \times 10^{-7} \text{ m}^2$

$R = \frac{f l}{A} = l = \frac{RA}{f} = \frac{125 \times 5 \times 10^{-7}}{1 \times 10^{-6}} = 625 \times 10^{-1} = 62.5 \text{ m}$

(c) $62.5 = 2\pi r \times n$, $62.5 = 3 \times 3.14 \times 4 \times 10^{-3} \times n$

$\Rightarrow n = \frac{62.5}{2 \times 3.14 \times 4 \times 10^{-3}} \Rightarrow n = \frac{62.5 \times 10^{-3}}{8 \times 3.14} \approx 2500 \text{ turns}$

5. $V = 250 \text{ V}$ $P = 100 \text{ w}$

$R = \frac{v^2}{P} = \frac{(250)^2}{100} = 625 \Omega$

Resistance of wire $R = \frac{f l}{A} = 1.7 \times 10^{-8} \times \frac{10}{5 \times 10^{-6}} = 0.034 \Omega$

\therefore The effect in resistance $= 625.034 \Omega$

\therefore The current in the conductor $= \frac{V}{R} = \left(\frac{220}{625.034} \right) \text{ A}$

\therefore The power supplied by one side of connecting wire $= \left(\frac{220}{625.034} \right)^2 \times 0.034$

\therefore The total power supplied $= \left(\frac{220}{625.034} \right)^2 \times 0.034 \times 2 = 0.0084 \text{ w} = 8.4 \text{ mw}$

6. $E = 220 \text{ v}$ $P = 60 \text{ w}$

$R = \frac{V^2}{P} = \frac{220 \times 220}{60} = \frac{220 \times 11}{3} \Omega$

(a) $E = 180 \text{ v}$ $P = \frac{V^2}{R} = \frac{180 \times 180 \times 3}{220 \times 11} = 40.16 \approx 40 \text{ w}$

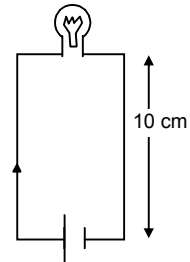

- (b) $E = 240 \text{ v}$ $P = \frac{V^2}{R} = \frac{240 \times 240 \times 3}{220 \times 11} = 71.4 \approx 71 \text{ w}$
7. Output voltage = $220 \pm 1\%$ $1\% \text{ of } 220 \text{ V} = 2.2 \text{ v}$
- The resistance of bulb $R = \frac{V^2}{P} = \frac{(220)^2}{100} = 484 \Omega$
- (a) For minimum power consumed $V_1 = 220 - 1\% = 220 - 2.2 = 217.8$
 $\therefore i = \frac{V_1}{R} = \frac{217.8}{484} = 0.45 \text{ A}$
 Power consumed = $i \times V_1 = 0.45 \times 217.8 = 98.01 \text{ W}$
- (b) for maximum power consumed $V_2 = 220 + 1\% = 220 + 2.2 = 222.2$
 $\therefore i = \frac{V_2}{R} = \frac{222.2}{484} = 0.459$
 Power consumed = $i \times V_2 = 0.459 \times 222.2 = 102 \text{ W}$
8. $V = 220 \text{ v}$ $P = 100 \text{ w}$
 $R = \frac{V^2}{P} = \frac{220 \times 220}{100} = 484 \Omega$
 $P = 150 \text{ w}$ $V = \sqrt{PR} = \sqrt{150 \times 22 \times 22} = 22\sqrt{150} = 269.4 \approx 270 \text{ v}$
9. $P = 1000$ $V = 220 \text{ v}$ $R = \frac{V^2}{P} = \frac{48400}{1000} = 48.4 \Omega$
- Mass of water = $\frac{1}{100} \times 1000 = 10 \text{ kg}$
- Heat required to raise the temp. of given amount of water = $ms\Delta t = 10 \times 4200 \times 25 = 1050000$
- Now heat liberated is only 60%. So $\frac{V^2}{R} \times T \times 60\% = 1050000$
- $\Rightarrow \frac{(220)^2}{48.4} \times \frac{60}{100} \times T = 1050000 \Rightarrow T = \frac{105000}{6} \times \frac{1}{60} \text{ nub} = 29.16 \text{ min.}$
10. Volume of water boiled = $4 \times 200 \text{ cc} = 800 \text{ cc}$
 $T_1 = 25^\circ\text{C}$ $T_2 = 100^\circ\text{C}$ $\Rightarrow T_2 - T_1 = 75^\circ\text{C}$
 Mass of water boiled = $800 \times 1 = 800 \text{ gm} = 0.8 \text{ kg}$
 $Q(\text{heat req.}) = MS\Delta\theta = 0.8 \times 4200 \times 75 = 252000 \text{ J.}$
 $1000 \text{ watt - hour} = 1000 \times 3600 \text{ watt-sec} = 1000 \times 3600 \text{ J}$
 No. of units = $\frac{252000}{1000 \times 3600} = 0.07 = 7 \text{ paise}$
- (b) $Q = mS\Delta T = 0.8 \times 4200 \times 95 \text{ J}$
 No. of units = $\frac{0.8 \times 4200 \times 95}{1000 \times 3600} = 0.0886 \approx 0.09$
 Money consumed = $0.09 \text{ Rs} = 9 \text{ paise.}$
11. $P = 100 \text{ w}$ $V = 220 \text{ v}$
 Case I : Excess power = $100 - 40 = 60 \text{ w}$
 Power converted to light = $\frac{60 \times 60}{100} = 36 \text{ w}$
- Case II : Power = $\frac{(220)^2}{484} = 82.64 \text{ w}$
 Excess power = $82.64 - 40 = 42.64 \text{ w}$
 Power converted to light = $42.64 \times \frac{60}{100} = 25.584 \text{ w}$

$$\Delta P = 36 - 25.584 = 10.416$$

$$\text{Required \%} = \frac{10.416}{36} \times 100 = 28.93 \approx 29\%$$

$$12. R_{\text{eff}} = \frac{12}{8} + 1 = \frac{5}{2} \quad i = \frac{6}{(5/2)} = \frac{12}{5} \text{ Amp.}$$

$$i' \cdot 6 = (i - i') \cdot 2 \Rightarrow i' \cdot 6 = \frac{12}{5} \times 2 - 2i'$$

$$8i' = \frac{24}{5} \Rightarrow i' = \frac{24}{5 \times 8} = \frac{3}{5} \text{ Amp}$$

$$i - i' = \frac{12}{5} - \frac{3}{5} = \frac{9}{5} \text{ Amp}$$

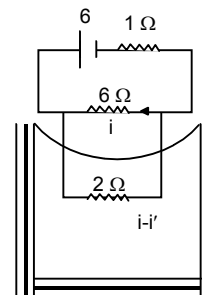

$$(a) \text{ Heat} = i^2 R T = \frac{9}{5} \times \frac{9}{5} \times 2 \times 15 \times 60 = 5832$$

2000 J of heat raises the temp. by 1K

5832 J of heat raises the temp. by 2.916K.

(b) When 6Ω resistor get burnt $R_{\text{eff}} = 1 + 2 = 3 \Omega$

$$i = \frac{6}{3} = 2 \text{ Amp.}$$

$$\text{Heat} = 2 \times 2 \times 2 \times 15 \times 60 = 7200 \text{ J}$$

2000 J raises the temp. by 1K

7200 J raises the temp by 3.6k

$$13. \theta = 0.001^\circ\text{C} \quad a = -46 \times 10^{-6} \text{ v/deg}, \quad b = -0.48 \times 10^{-6} \text{ v/deg}^2$$

$$\text{Emf} = a_{\text{BiAg}} \theta + (1/2) b_{\text{BiAg}} \theta^2 = -46 \times 10^{-6} \times 0.001 - (1/2) \times 0.48 \times 10^{-6} (0.001)^2$$

$$= -46 \times 10^{-9} - 0.24 \times 10^{-12} = -46.00024 \times 10^{-9} = -4.6 \times 10^{-8} \text{ V}$$

$$14. E = a_{\text{AB}}\theta + b_{\text{AB}}\theta^2 \quad a_{\text{CuAg}} = a_{\text{CuPb}} - b_{\text{AgPb}} = 2.76 - 2.5 = 0.26 \mu\text{V}/^\circ\text{C}$$

$$b_{\text{CuAg}} = b_{\text{CuPb}} - b_{\text{AgPb}} = 0.012 - 0.012 \mu\text{VC} = 0$$

$$E = a_{\text{AB}}\theta = (0.26 \times 40) \mu\text{V} = 1.04 \times 10^{-5} \text{ V}$$

$$15. \theta = 0^\circ\text{C}$$

$$a_{\text{Cu,Fe}} = a_{\text{Cu,Pb}} - a_{\text{Fe,Pb}} = 2.76 - 16.6 = -13.8 \mu\text{V}/^\circ\text{C}$$

$$b_{\text{Cu,Fe}} = b_{\text{Cu,Pb}} - b_{\text{Fe,Pb}} = 0.012 + 0.030 = 0.042 \mu\text{V}/^\circ\text{C}^2$$

$$\text{Neutral temp. on } -\frac{a}{b} = \frac{13.8}{0.042} ^\circ\text{C} = 328.57^\circ\text{C}$$

16. (a) 1eq. mass of the substance requires 96500 coulombs

Since the element is monoatomic, thus eq. mass = mol. Mass

$$6.023 \times 10^{23} \text{ atoms require } 96500 \text{ C}$$

$$1 \text{ atoms require } \frac{96500}{6.023 \times 10^{23}} \text{ C} = 1.6 \times 10^{-19} \text{ C}$$

(b) Since the element is diatomic eq.mass = (1/2) mol.mass

$$\therefore (1/2) \times 6.023 \times 10^{23} \text{ atoms } 2\text{eq. } 96500 \text{ C}$$

$$\Rightarrow 1 \text{ atom require } = \frac{96500 \times 2}{6.023 \times 10^{23}} = 3.2 \times 10^{-19} \text{ C}$$

17. At Wt. At = 107.9 g/mole

$$I = 0.500 \text{ A}$$

$$E_{\text{Ag}} = 107.9 \text{ g} \quad [\text{As Ag is monoatomic}]$$

$$Z_{\text{Ag}} = \frac{E}{f} = \frac{107.9}{96500} = 0.001118$$

$$M = Zit = 0.001118 \times 0.5 \times 3600 = 2.01$$

18. $t = 3 \text{ min} = 180 \text{ sec}$ $w = 2 \text{ g}$
 $E.C.E = 1.12 \times 10^{-6} \text{ kg/c}$
 $\Rightarrow 3 \times 10^{-3} = 1.12 \times 10^{-6} \times i \times 180$
 $\Rightarrow i = \frac{3 \times 10^{-3}}{1.12 \times 10^{-6} \times 180} = \frac{1}{6.72} \times 10^2 \approx 15 \text{ Amp.}$
19. $\frac{H_2}{22.4L} \rightarrow 2g$ $1L \rightarrow \frac{2}{22.4}$
 $m = Zit$ $\frac{2}{22.4} = \frac{1}{96500} \times 5 \times T \Rightarrow T = \frac{2}{22.4} \times \frac{96500}{5} = 1732.21 \text{ sec} \approx 28.7 \text{ min} \approx 29 \text{ min.}$
20. $w_1 = Zit \Rightarrow 1 = \frac{\text{mm}}{3 \times 96500} \times 2 \times 1.5 \times 3600 \Rightarrow \text{mm} = \frac{3 \times 96500}{2 \times 1.5 \times 3600} = 26.8 \text{ g/mole}$
 $\frac{E_1}{E_2} = \frac{w_1}{w_2} \Rightarrow \frac{107.9}{\left(\frac{\text{mm}}{3}\right)} = \frac{w_1}{1} \Rightarrow w_1 = \frac{107.9 \times 3}{26.8} = 12.1 \text{ gm}$
21. $I = 15 \text{ A}$ Surface area = 200 cm^2 , Thickness = 0.1 mm
Volume of Ag deposited = $200 \times 0.01 = 2 \text{ cm}^3$ for one side
For both sides, Mass of Ag = $4 \times 10.5 = 42 \text{ g}$
 $Z_{Ag} = \frac{E}{F} = \frac{107.9}{96500}$ $m = Zit$
 $\Rightarrow 42 = \frac{107.9}{96500} \times 15 \times T \Rightarrow T = \frac{42 \times 96500}{107.9 \times 15} = 2504.17 \text{ sec} = 41.73 \text{ min} \approx 42 \text{ min}$
22. $w = Zit$
 $2.68 = \frac{107.9}{96500} \times i \times 10 \times 60$
 $\Rightarrow i = \frac{2.68 \times 965}{107.9 \times 6} = 3.99 \approx 4 \text{ Amp}$
Heat developed in the 20Ω resistor = $(4)^2 \times 20 \times 10 \times 60 = 192000 \text{ J} = 192 \text{ KJ}$
23. For potential drop, $t = 30 \text{ min} = 180 \text{ sec}$
 $V_i = V_f + iR \Rightarrow 12 = 10 + 2i \Rightarrow i = 1 \text{ Amp}$
 $m = Zit = \frac{107.9}{96500} \times 1 \times 30 \times 60 = 2.01 \text{ g} \approx 2 \text{ g}$
24. $A = 10 \text{ cm}^2 \times 10^{-4} \text{ cm}^2$
 $t = 10 \text{ m} = 10 \times 10^{-6}$
Volume = $A(2t) = 10 \times 10^{-4} \times 2 \times 10 \times 10^{-6} = 2 \times 10^2 \times 10^{-10} = 2 \times 10^{-8} \text{ m}^3$
Mass = $2 \times 10^{-8} \times 9000 = 18 \times 10^{-5} \text{ kg}$
 $W = Z \times C \Rightarrow 18 \times 10^{-5} = 3 \times 10^{-7} \times C$
 $\Rightarrow q = \frac{18 \times 10^{-5}}{3 \times 10^{-7}} = 6 \times 10^2$
 $V = \frac{W}{q} \Rightarrow W = Vq = 12 \times 6 \times 10^2 = 76 \times 10^2 = 7.6 \text{ KJ}$

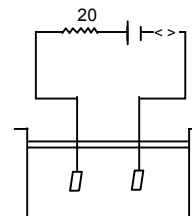

CHAPTER – 34 MAGNETIC FIELD

- $q = 2 \times 1.6 \times 10^{-19} \text{ C}$, $v = 3 \times 10^4 \text{ km/s} = 3 \times 10^7 \text{ m/s}$
 $B = 1 \text{ T}$, $F = qvB = 2 \times 1.6 \times 10^{-19} \times 3 \times 10^7 \times 1 = 9.6 \times 10^{-12} \text{ N}$ towards west.
- $KE = 10 \text{ Kev} = 1.6 \times 10^{-15} \text{ J}$, $\vec{B} = 1 \times 10^{-7} \text{ T}$
(a) The electron will be deflected towards left

(b) $(1/2)mv^2 = KE \Rightarrow v = \sqrt{\frac{KE \times 2}{m}}$ $F = qvB$ & $accln = \frac{qVB}{m_e}$

Applying $s = ut + (1/2)at^2 = \frac{1}{2} \times \frac{qVB}{m_e} \times \frac{x^2}{v^2} = \frac{qBx^2}{2m_e v}$

$$= \frac{qBx^2}{2m_e \sqrt{\frac{KE \times 2}{m}}} = \frac{1}{2} \times \frac{1.6 \times 10^{-19} \times 1 \times 10^{-7} \times x^2}{9.1 \times 10^{-31} \times \sqrt{\frac{1.6 \times 10^{-15} \times 2}{9.1 \times 10^{-31}}}}$$

By solving we get, $s = 0.0148 \approx 1.5 \times 10^{-2} \text{ cm}$

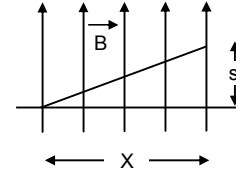

- $B = 4 \times 10^{-3} \text{ T}$ (\hat{k})
 $F = [4\hat{i} + 3\hat{j}] \times 10^{-10} \text{ N}$. $F_x = 4 \times 10^{-10} \text{ N}$ $F_y = 3 \times 10^{-10} \text{ N}$
 $Q = 1 \times 10^{-9} \text{ C}$.

Considering the motion along x-axis :-

$$F_x = quv_y B \Rightarrow v_y = \frac{F}{qB} = \frac{4 \times 10^{-10}}{1 \times 10^{-9} \times 4 \times 10^{-3}} = 100 \text{ m/s}$$

Along y-axis

$$F_y = qv_x B \Rightarrow v_x = \frac{F}{qB} = \frac{3 \times 10^{-10}}{1 \times 10^{-9} \times 4 \times 10^{-3}} = 75 \text{ m/s}$$

Velocity = $(-75\hat{i} + 100\hat{j}) \text{ m/s}$

- $\vec{B} = (7.0\hat{i} - 3.0\hat{j}) \times 10^{-3} \text{ T}$
 $\vec{a} = \text{acceleration} = (-i + 7j) \times 10^{-6} \text{ m/s}^2$
Let the gap be x.

Since \vec{B} and \vec{a} are always perpendicular

$$\vec{B} \times \vec{a} = 0$$

$$\Rightarrow (7x \times 10^{-3} \times 10^{-6} - 3 \times 10^{-3} \times 7 \times 10^{-6}) = 0$$

$$\Rightarrow 7x - 21 = 0 \Rightarrow x = 3$$

- $m = 10 \text{ g} = 10 \times 10^{-3} \text{ kg}$
 $q = 400 \text{ mc} = 400 \times 10^{-6} \text{ C}$
 $v = 270 \text{ m/s}$, $B = 500 \mu\text{T} = 500 \times 10^{-6} \text{ Tesla}$
Force on the particle = $quB = 4 \times 10^{-6} \times 270 \times 500 \times 10^{-6} = 54 \times 10^{-8} \text{ (K)}$
Acceleration on the particle = $54 \times 10^{-6} \text{ m/s}^2 \text{ (K)}$

Velocity along \hat{i} and acceleration along \hat{k}
along x-axis the motion is uniform motion and
along y-axis it is accelerated motion.

Along - X axis $100 = 270 \times t \Rightarrow t = \frac{10}{27}$

Along - Z axis $s = ut + (1/2)at^2$
 $\Rightarrow s = \frac{1}{2} \times 54 \times 10^{-6} \times \frac{10}{27} \times \frac{10}{27} = 3.7 \times 10^{-6}$

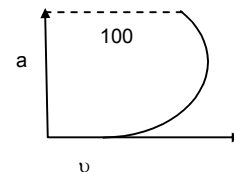

6. $q_p = e, \quad m_p = m, \quad F = q_p \times E$
 or $ma_0 = eE$ or, $E = \frac{ma_0}{e}$ towards west

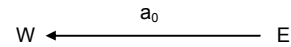

The acceleration changes from a_0 to $3a_0$
 Hence net acceleration produced by magnetic field \vec{B} is $2a_0$.
 Force due to magnetic field
 $= \vec{F}_B = m \times 2a_0 = e \times V_0 \times B$
 $\Rightarrow B = \frac{2ma_0}{eV_0}$ downwards

7. $l = 10 \text{ cm} = 10 \times 10^{-3} \text{ m} = 10^{-1} \text{ m}$
 $i = 10 \text{ A}, \quad B = 0.1 \text{ T}, \quad \theta = 53^\circ$
 $|F| = i l B \sin \theta = 10 \times 10^{-1} \times 0.1 \times 0.79 = 0.0798 \approx 0.08$
 direction of F is along a direction \perp to both l and B .

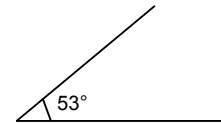

8. $\vec{F} = i l B = 1 \times 0.20 \times 0.1 = 0.02 \text{ N}$
 For $\vec{F} = i l \times B$
 So, For
 da & $cb \rightarrow l \times B = l B \sin 90^\circ$ towards left
 Hence $\vec{F} = 0.02 \text{ N}$ towards left
 For
 dc & $ab \rightarrow \vec{F} = 0.02 \text{ N}$ downward

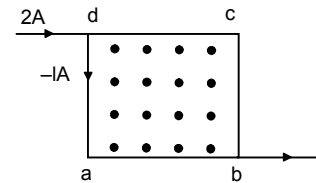

9. $F = i l B \sin \theta$
 $= i l B \sin 90^\circ$
 $= i 2RB$
 $= 2 \times (8 \times 10^{-2}) \times 1$
 $= 16 \times 10^{-2}$
 $= 0.16 \text{ N}.$

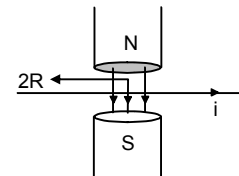

10. Length = l , Current = $I \hat{i}$
 $\vec{B} = B_0(\hat{i} + \hat{j} + \hat{k}) \text{ T} = B_0\hat{i} + B_0\hat{j} + B_0\hat{k}$
 $F = I l \times \vec{B} = I l \hat{i} \times B_0\hat{i} + B_0\hat{j} + B_0\hat{k}$
 $= I l B_0 \hat{i} \times \hat{i} + I B_0 \hat{i} \times \hat{j} + I B_0 \hat{i} \times \hat{k} = I l B_0 \hat{k} - I l B_0 \hat{j}$
 or, $|\vec{F}| = \sqrt{2I^2 l^2 B_0^2} = \sqrt{2} I l B_0$

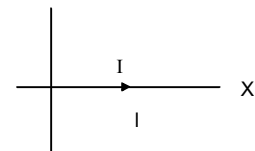

11. $i = 5 \text{ A}, \quad l = 50 \text{ cm} = 0.5 \text{ m}$
 $B = 0.2 \text{ T},$
 $F = i l B \sin \theta = i l B \sin 90^\circ$
 $= 5 \times 0.5 \times 0.2$
 $= 0.05 \text{ N}$
 (\hat{j})

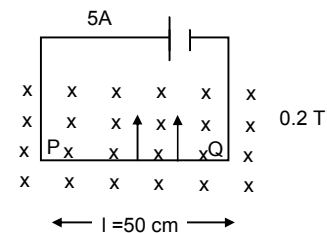

12. $l = 2\pi a$
 Magnetic field = \vec{B} radially outwards
 Current $\Rightarrow 'i'$
 $F = i l \times B$
 $= i \times (2\pi a \times \vec{B})$
 $\otimes = 2\pi a i B$ perpendicular to the plane of the figure going inside.

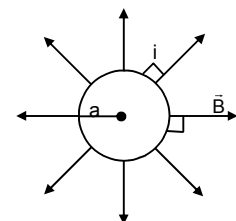

13. $\vec{B} = B_0 \vec{e}_r$
 \vec{e}_r = Unit vector along radial direction
 $F = i(\vec{l} \times \vec{B}) = i l B \sin \theta$
 $= \frac{i(2\pi a) B_0 a}{\sqrt{a^2 + d^2}} = \frac{i 2\pi a^2 B_0}{\sqrt{a^2 + d^2}}$

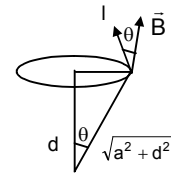
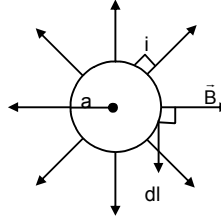

14. Current anticlockwise
 Since the horizontal Forces have no effect.
 Let us check the forces for current along AD & BC [Since there is no \vec{B}]
 In AD, $F = 0$
 For BC
 $F = iaB$ upward
 Current clockwise
 Similarly, $F = -iaB$ downwards
 Hence change in force = change in tension
 $= iaB - (-iaB) = 2 iaB$

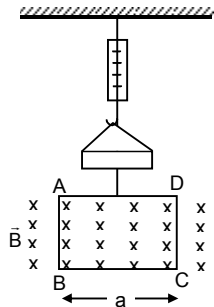

15. $F_1 =$ Force on AD = $i l B$ inwards
 $F_2 =$ Force on BC = $i l B$ inwards
 They cancel each other
 $F_3 =$ Force on CD = $i l B$ inwards
 $F_4 =$ Force on AB = $i l B$ inwards
 They also cancel each other.
 So the net force on the body is 0.

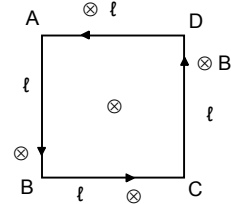

16. For force on a current carrying wire in an uniform magnetic field
 We need, $l \rightarrow$ length of wire
 $i \rightarrow$ Current
 $B \rightarrow$ Magnitude of magnetic field

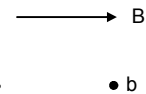

Since $\vec{F} = i l B$

Now, since the length of the wire is fixed from A to B, so force is independent of the shape of the wire.

17. Force on a semicircular wire
 $= 2iRB$
 $= 2 \times 5 \times 0.05 \times 0.5$
 $= 0.25 \text{ N}$

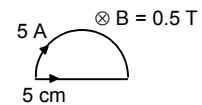

18. Here the displacement vector $d\vec{l} = \lambda$
 So magnetic for $i \rightarrow d\vec{l} \times \vec{B} = i \times \lambda B$

19. Force due to the wire AB and force due to wire CD are equal and opposite to each other. Thus they cancel each other.
 Net force is the force due to the semicircular loop = $2iRB$

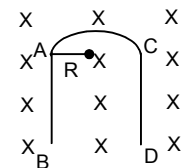

20. Mass = $10 \text{ mg} = 10^{-5} \text{ kg}$
 Length = 1 m
 $I = 2 \text{ A}, \quad B = ?$
 Now, $Mg = i l B$
 $\Rightarrow B = \frac{mg}{il} = \frac{10^{-5} \times 9.8}{2 \times 1} = 4.9 \times 10^{-5} \text{ T}$

21. (a) When switch S is open
 $2T \cos 30^\circ = mg$
 $\Rightarrow T = \frac{mg}{2 \cos 30^\circ}$
 $= \frac{200 \times 10^{-3} \times 9.8}{2 \sqrt{3/2}} = 1.13$

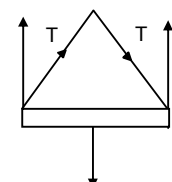
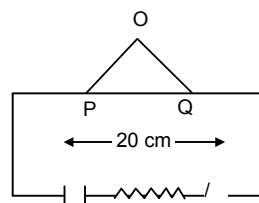

(b) When the switch is closed and a current passes through the circuit = 2 A

Then

$$\Rightarrow 2T \cos 30^\circ = mg + iB$$

$$= 200 \times 10^{-3} \times 9.8 + 2 \times 0.2 \times 0.5 = 1.96 + 0.2 = 2.16$$

$$\Rightarrow 2T = \frac{2.16 \times 2}{\sqrt{3}} = 2.49$$

$$\Rightarrow T = \frac{2.49}{2} = 1.245 \approx 1.25$$

22. Let 'F' be the force applied due to magnetic field on the wire and 'x' be the dist covered.

So, $F \times l = \mu mg \times x$

$$\Rightarrow ibl = \mu mgx$$

$$\Rightarrow x = \frac{ibl}{\mu mg}$$

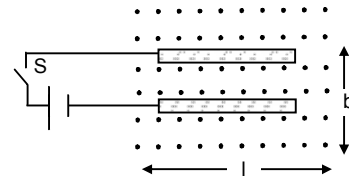

23. $\mu R = F$

$$\Rightarrow \mu \times m \times g = ilB$$

$$\Rightarrow \mu \times 10 \times 10^{-3} \times 9.8 = \frac{6}{20} \times 4.9 \times 10^{-2} \times 0.8$$

$$\Rightarrow \mu = \frac{0.3 \times 0.8 \times 10^{-2}}{2 \times 10^{-2}} = 0.12$$

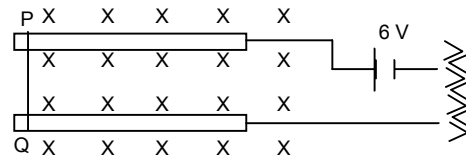

24. Mass = m

length = l

Current = i

Magnetic field = B = ?

friction Coefficient = μ

$$iBl = \mu mg$$

$$\Rightarrow B = \frac{\mu mg}{il}$$

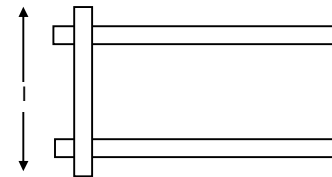

25. (a) $F_{dl} = i \times dl \times B$ towards centre. (By cross product rule)

(b) Let the length of subtends an small angle of 2θ at the centre.

Here $2T \sin \theta = i \times dl \times B$

$$\Rightarrow 2T\theta = i \times a \times 2\theta \times B \quad [\text{As } \theta \rightarrow 0, \sin \theta \approx \theta]$$

$$\Rightarrow T = i \times a \times B \quad dl = a \times 2\theta$$

Force of compression on the wire = $i \times a \times B$

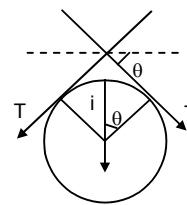

$$26. Y = \frac{\text{Stress}}{\text{Strain}} = \frac{\left(\frac{F}{\pi r^2}\right)}{\left(\frac{dl}{L}\right)}$$

$$\Rightarrow \frac{dl}{L} Y = \frac{F}{\pi r^2} \Rightarrow dl = \frac{F}{\pi r^2} \times \frac{L}{Y}$$

$$= \frac{iaB}{\pi r^2} \times \frac{2\pi a}{Y} = \frac{2\pi a^2 iB}{\pi r^2 Y}$$

$$\text{So, } dp = \frac{2\pi a^2 iB}{\pi r^2 Y} \quad (\text{for small cross sectional circle})$$

$$dr = \frac{2\pi a^2 iB}{\pi r^2 Y} \times \frac{1}{2\pi} = \frac{a^2 iB}{\pi r^2 Y}$$

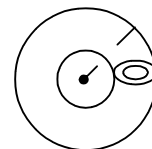

27. $\vec{B} = B_0 \left(1 + \frac{x}{l} \right) \hat{k}$

$f_1 = \text{force on AB} = iB_0[1 + 0]l = iB_0l$
 $f_2 = \text{force on CD} = iB_0[1 + 0]l = iB_0l$
 $f_3 = \text{force on AD} = iB_0[1 + 0/1]l = iB_0l$
 $f_4 = \text{force on BC} = iB_0[1 + 1/1]l = 2iB_0l$
 Net horizontal force = $F_1 - F_2 = 0$
 Net vertical force = $F_4 - F_3 = iB_0l$

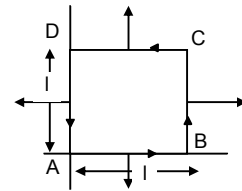

28. (a) Velocity of electron = v
 Magnetic force on electron

$F = evB$
 (b) $F = qE$; $F = evB$
 or, $qE = evB$

$\Rightarrow eE = evB$ or, $\vec{E} = vB$

(c) $E = \frac{dV}{dr} = \frac{V}{l}$

$\Rightarrow V = IE = l v B$

29. (a) $i = V_0 n A e$

$\Rightarrow V_0 = \frac{i}{n A e}$

(b) $F = i l B = \frac{i B l}{n A} = \frac{i B}{n A}$ (upwards)

(c) Let the electric field be E

$E e = \frac{i B}{A n} \Rightarrow E = \frac{i B}{A e n}$

(d) $\frac{dv}{dr} = E \Rightarrow dV = E dr$

$= E \times d = \frac{i B}{A e n} d$

30. $q = 2.0 \times 10^{-8} \text{ C}$ $\vec{B} = 0.10 \text{ T}$

$m = 2.0 \times 10^{-10} \text{ g} = 2 \times 10^{-13} \text{ g}$

$v = 2.0 \times 10^3 \text{ m/s}$

$R = \frac{mv}{qB} = \frac{2 \times 10^{-13} \times 2 \times 10^3}{2 \times 10^{-8} \times 10^{-1}} = 0.2 \text{ m} = 20 \text{ cm}$

$T = \frac{2\pi m}{qB} = \frac{2 \times 3.14 \times 2 \times 10^{-13}}{2 \times 10^{-8} \times 10^{-1}} = 6.28 \times 10^{-4} \text{ s}$

31. $r = \frac{mv}{qB}$

$0.01 = \frac{mv}{e \cdot 0.1}$... (1)

$r = \frac{4m \times V}{2e \times 0.1}$... (2)

(2) \div (1)

$\Rightarrow \frac{r}{0.01} = \frac{4mVe \times 0.1}{2e \times 0.1 \times mv} = \frac{4}{2} = 2 \Rightarrow r = 0.02 \text{ m} = 2 \text{ cm}$

32. $KE = 100ev = 1.6 \times 10^{-17} \text{ J}$

$(1/2) \times 9.1 \times 10^{-31} \times V^2 = 1.6 \times 10^{-17} \text{ J}$

$\Rightarrow V^2 = \frac{1.6 \times 10^{-17} \times 2}{9.1 \times 10^{-31}} = 0.35 \times 10^{14}$

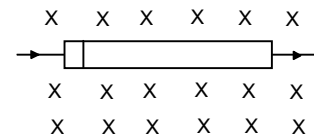
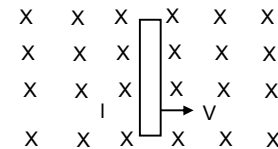

$$\text{or, } v = 0.591 \times 10^7 \text{ m/s}$$

$$\text{Now } r = \frac{mv}{qB} \Rightarrow \frac{9.1 \times 10^{-31} \times 0.591 \times 10^7}{1.6 \times 10^{-19} \times B} = \frac{10}{100}$$

$$\Rightarrow B = \frac{9.1 \times 0.591}{1.6} \times \frac{10^{-23}}{10^{-19}} = 3.3613 \times 10^{-4} \text{ T} \approx 3.4 \times 10^{-4} \text{ T}$$

$$T = \frac{2\pi m}{qB} = \frac{2 \times 3.14 \times 9.1 \times 10^{-31}}{1.6 \times 10^{-19} \times 3.4 \times 10^{-4}}$$

$$\text{No. of Cycles per Second } f = \frac{1}{T}$$

$$= \frac{1.6 \times 3.4}{2 \times 3.14 \times 9.1} \times \frac{10^{-19} \times 10^{-4}}{10^{-31}} = 0.0951 \times 10^8 \approx 9.51 \times 10^6$$

Note: \therefore Putting $B = 3.361 \times 10^{-4} \text{ T}$ We get $f = 9.4 \times 10^6$

33. Radius = l , K.E = K

$$L = \frac{mV}{qB} \Rightarrow l = \frac{\sqrt{2mk}}{qB}$$

$$\Rightarrow B = \frac{\sqrt{2mk}}{ql}$$

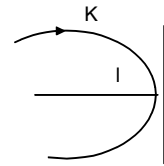

34. $V = 12 \text{ KV}$ $E = \frac{V}{l}$ Now, $F = qE = \frac{qV}{l}$ or, $a = \frac{F}{m} = \frac{qV}{ml}$

$$v = 1 \times 10^6 \text{ m/s}$$

$$\text{or } v = \sqrt{2 \times \frac{qV}{m} \times l} = \sqrt{2 \times \frac{q}{m} \times 12 \times 10^3}$$

$$\text{or } 1 \times 10^6 = \sqrt{2 \times \frac{q}{m} \times 12 \times 10^3}$$

$$\Rightarrow 10^{12} = 24 \times 10^3 \times \frac{q}{m}$$

$$\Rightarrow \frac{m}{q} = \frac{24 \times 10^3}{10^{12}} = 24 \times 10^{-9}$$

$$r = \frac{mV}{qB} = \frac{24 \times 10^{-9} \times 1 \times 10^6}{2 \times 10^{-1}} = 12 \times 10^{-2} \text{ m} = 12 \text{ cm}$$

35. $V = 10 \text{ Km/s} = 10^4 \text{ m/s}$

$$B = 1 \text{ T, } q = 2e.$$

$$(a) F = qVB = 2 \times 1.6 \times 10^{-19} \times 10^4 \times 1 = 3.2 \times 10^{-15} \text{ N}$$

$$(b) r = \frac{mV}{qB} = \frac{4 \times 1.6 \times 10^{-27} \times 10^4}{2 \times 1.6 \times 10^{-19} \times 1} = 2 \times \frac{10^{-23}}{10^{-19}} = 2 \times 10^{-4} \text{ m}$$

$$(c) \text{Time taken} = \frac{2\pi r}{V} = \frac{2\pi m v}{qB \times v} = \frac{2\pi \times 4 \times 1.6 \times 10^{-27}}{2 \times 1.6 \times 10^{-19} \times 1}$$

$$= 4\pi \times 10^{-8} = 4 \times 3.14 \times 10^{-8} = 12.56 \times 10^{-8} = 1.256 \times 10^{-7} \text{ sec.}$$

36. $v = 3 \times 10^6 \text{ m/s, } B = 0.6 \text{ T, } m = 1.67 \times 10^{-27} \text{ kg}$

$$F = qvB \quad q_p = 1.6 \times 10^{-19} \text{ C}$$

$$\text{or, } \bar{a} = \frac{F}{m} = \frac{qvB}{m}$$

$$= \frac{1.6 \times 10^{-19} \times 3 \times 10^6 \times 0.6}{1.67 \times 10^{-27}}$$

$$= 17.245 \times 10^{13} = 1.724 \times 10^4 \text{ m/s}^2$$

37. (a) $R = 1 \text{ n}$, $B = 0.5 \text{ T}$, $r = \frac{mv}{qB}$

$$\Rightarrow 1 = \frac{9.1 \times 10^{-31} \times v}{1.6 \times 10^{-19} \times 0.5}$$

$$\Rightarrow v = \frac{1.6 \times 0.5 \times 10^{-19}}{9.1 \times 10^{-31}} = 0.0879 \times 10^{10} \approx 8.8 \times 10^{10} \text{ m/s}$$

No, it is not reasonable as it is more than the speed of light.

(b) $r = \frac{mv}{qB}$

$$\Rightarrow 1 = \frac{1.6 \times 10^{-27} \times v}{1.6 \times 10^{-19} \times 0.5}$$

$$\Rightarrow v = \frac{1.6 \times 10^{-19} \times 0.5}{1.6 \times 10^{-27}} = 0.5 \times 10^8 = 5 \times 10^7 \text{ m/s.}$$

38. (a) Radius of circular arc = $\frac{mv}{qB}$

(b) Since MA is tangent to arc ABC, described by the particle.

Hence $\angle MAO = 90^\circ$

Now, $\angle NAC = 90^\circ$ [\because NA is \perp r]

$\therefore \angle OAC = \angle OCA = \theta$ [By geometry]

Then $\angle AOC = 180 - (\theta + \theta) = \pi - 2\theta$

(c) Dist. Covered $l = r\theta = \frac{mv}{qB} (\pi - 2\theta)$

$$t = \frac{l}{v} = \frac{m}{qB} (\pi - 2\theta)$$

(d) If the charge 'q' on the particle is negative. Then

(i) Radius of Circular arc = $\frac{mv}{qB}$

(ii) In such a case the centre of the arc will lie with in the magnetic field, as seen in the fig. Hence the angle subtended by the major arc = $\pi + 2\theta$

(iii) Similarly the time taken by the particle to cover the same path = $\frac{m}{qB} (\pi + 2\theta)$

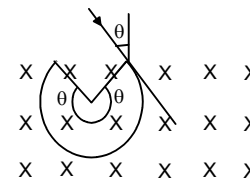
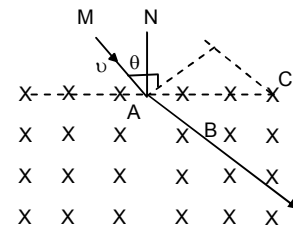

39. Mass of the particle = m, Charge = q, Width = d

(a) If $d = \frac{mV}{qB}$

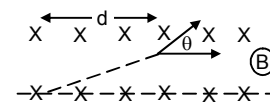
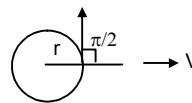

The d is equal to radius. θ is the angle between the radius and tangent which is equal to $\pi/2$ (As shown in the figure)

(b) If $\approx \frac{mV}{2qB}$ distance travelled = (1/2) of radius

Along x-directions $d = V_x t$ [Since acceleration in this direction is 0. Force acts along \hat{j} directions]

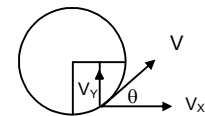

$$t = \frac{d}{V_x} \quad \dots(1)$$

$$V_y = u_y + a_y t = \frac{0 + qu_x B t}{m} = \frac{qu_x B t}{m}$$

From (1) putting the value of t, $V_y = \frac{qu_x B d}{mV_x}$

$$\tan \theta = \frac{V_y}{V_x} = \frac{qBd}{mV_x} = \frac{qBmV_x}{2qBmV_x} = \frac{1}{2}$$

$$\Rightarrow \theta = \tan^{-1} \left(\frac{1}{2} \right) = 26.4 \approx 30^\circ = \pi/6$$

$$(c) d \approx \frac{2mu}{qB}$$

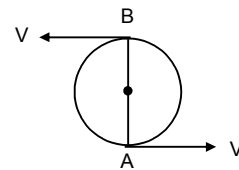

40. $u = 6 \times 10^4$ m/s, $B = 0.5$ T, $r_1 = 3/2 = 1.5$ cm, $r_2 = 3.5/2$ cm

$$r_1 = \frac{mv}{qB} = \frac{A \times (1.6 \times 10^{-27}) \times 6 \times 10^4}{1.6 \times 10^{-19} \times 0.5}$$

$$\Rightarrow 1.5 = A \times 12 \times 10^{-4}$$

$$\Rightarrow A = \frac{1.5}{12 \times 10^{-4}} = \frac{15000}{12}$$

$$r_2 = \frac{mu}{qB} \Rightarrow \frac{3.5}{2} = \frac{A' \times (1.6 \times 10^{-27}) \times 6 \times 10^4}{1.6 \times 10^{-19} \times 0.5}$$

$$\Rightarrow A' = \frac{3.5 \times 0.5 \times 10^{-19}}{2 \times 6 \times 10^4 \times 10^{-27}} = \frac{3.5 \times 0.5 \times 10^4}{12}$$

$$\frac{A}{A'} = \frac{1.5}{12 \times 10^{-4}} \times \frac{12 \times 10^{-4}}{3.5 \times 0.5} = \frac{6}{7}$$

Taking common ratio = 2 (For Carbon). The isotopes used are C^{12} and C^{14}

41. $V = 500$ V, $B = 20$ mT = (2×10^{-3}) T

$$E = \frac{V}{d} = \frac{500}{d} \Rightarrow F = \frac{q500}{d} \Rightarrow a = \frac{q500}{dm}$$

$$\Rightarrow u^2 = 2ad = 2 \times \frac{q500}{dm} \times d \Rightarrow u^2 = \frac{1000 \times q}{m} \Rightarrow u = \sqrt{\frac{1000 \times q}{m}}$$

$$r_1 = \frac{m_1 \sqrt{1000 \times q_1}}{q_1 \sqrt{m_1 B}} = \frac{\sqrt{m_1} \sqrt{1000}}{\sqrt{q_1} B} = \frac{\sqrt{57 \times 1.6 \times 10^{-27} \times 10^3}}{\sqrt{1.6 \times 10^{-19} \times 2 \times 10^{-3}}} = 1.19 \times 10^{-2} \text{ m} = 119 \text{ cm}$$

$$r_1 = \frac{m_2 \sqrt{1000 \times q_2}}{q_2 \sqrt{m_2 B}} = \frac{\sqrt{m_2} \sqrt{1000}}{\sqrt{q_2} B} = \frac{\sqrt{1000 \times 58 \times 1.6 \times 10^{-27}}}{\sqrt{1.6 \times 10^{-19} \times 20 \times 10^{-3}}} = 1.20 \times 10^{-2} \text{ m} = 120 \text{ cm}$$

42. For K - 39 : $m = 39 \times 1.6 \times 10^{-27}$ kg, $B = 5 \times 10^{-1}$ T, $q = 1.6 \times 10^{-19}$ C, K.E = 32 KeV.
Velocity of projection : $= (1/2) \times 39 \times (1.6 \times 10^{-27}) v^2 = 32 \times 10^3 \times 1.6 \times 10^{-27} \Rightarrow v = 4.050957468 \times 10^5$
Through out ht emotion the horizontal velocity remains constant.

$$t = \frac{0.01}{40.50957468 \times 10^5} = 24 \times 10^{-9} \text{ sec. [Time taken to cross the magnetic field]}$$

$$\text{Accln. In the region having magnetic field} = \frac{qvB}{m}$$

$$= \frac{1.6 \times 10^{-19} \times 4.050957468 \times 10^5 \times 0.5}{39 \times 1.6 \times 10^{-27}} = 5193.535216 \times 10^8 \text{ m/s}^2$$

$$V(\text{in vertical direction}) = at = 5193.535216 \times 10^8 \times 24 \times 10^{-9} = 12464.48452 \text{ m/s.}$$

$$\text{Total time taken to reach the screen} = \frac{0.965}{40.50957468 \times 10^5} = 0.000002382 \text{ sec.}$$

$$\text{Time gap} = 2383 \times 10^{-9} - 24 \times 10^{-9} = 2358 \times 10^{-9} \text{ sec.}$$

$$\text{Distance moved vertically (in the time)} = 12464.48452 \times 2358 \times 10^{-9} = 0.0293912545 \text{ m}$$

$$V^2 = 2as \Rightarrow (12464.48452)^2 = 2 \times 5193.535216 \times 10^8 \times S \Rightarrow S = 0.1495738143 \times 10^{-3} \text{ m.}$$

$$\text{Net displacement from line} = 0.0001495738143 + 0.0293912545 = 0.0295408283143 \text{ m}$$

$$\text{For K - 41 : } (1/2) \times 41 \times 1.6 \times 10^{-27} v^2 = 32 \times 10^3 \times 1.6 \times 10^{-27} \Rightarrow v = 39.50918387 \text{ m/s.}$$

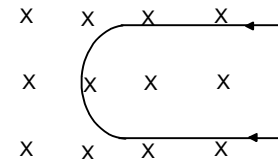

$$a = \frac{qvB}{m} = \frac{1.6 \times 10^{-19} \times 395091.8387 \times 0.5}{41 \times 1.6 \times 10^{-27}} = 4818.193154 \times 10^8 \text{ m/s}^2$$

$$t = (\text{time taken for coming outside from magnetic field}) = \frac{0.1}{39501.8387} = 25 \times 10^{-9} \text{ sec.}$$

$$V = at \text{ (Vertical velocity)} = 4818.193154 \times 10^8 \times 25 \times 10^{-9} = 12045.48289 \text{ m/s.}$$

$$\text{(Time total to reach the screen)} = \frac{0.965}{395091.8387} = 0.000002442$$

$$\text{Time gap} = 2442 \times 10^{-9} - 25 \times 10^{-9} = 2417 \times 10^{-9}$$

$$\text{Distance moved vertically} = 12045.48289 \times 2417 \times 10^{-9} = 0.02911393215$$

$$\text{Now, } V^2 = 2as \Rightarrow (12045.48289)^2 = 2 \times 4818.193151 \times S \Rightarrow S = 0.0001505685363 \text{ m}$$

$$\text{Net distance travelled} = 0.0001505685363 + 0.02911393215 = 0.0292645006862$$

$$\text{Net gap between K-39 and K-41} = 0.0295408283143 - 0.0292645006862 = 0.0001763276281 \text{ m} \approx 0.176 \text{ mm}$$

43. The object will make a circular path, perpendicular to the plane of paper
Let the radius of the object be r

$$\frac{mv^2}{r} = qvB \Rightarrow r = \frac{mV}{qB}$$

Here object distance $K = 18 \text{ cm.}$

$$\frac{1}{v} - \frac{1}{u} = \frac{1}{f} \text{ (lens eqn.)} \Rightarrow \frac{1}{v} - \left(\frac{1}{-18}\right) = \frac{1}{12} \Rightarrow v = 36 \text{ cm.}$$

Let the radius of the circular path of image = r'

$$\text{So magnification} = \frac{v}{u} = \frac{r'}{r} \text{ (magnetic path} = \frac{\text{image height}}{\text{object height}}) \Rightarrow r' = \frac{v}{u}r \Rightarrow r' = \frac{36}{18} \times 4 = 8 \text{ cm.}$$

Hence radius of the circular path in which the image moves is 8 cm.

44. Given magnetic field = B , $Pd = V$, mass of electron = m , Charge = q ,

$$\text{Let electric field be 'E' } \therefore E = \frac{V}{R}, \quad \text{Force Experienced} = eE$$

$$\text{Acceleration} = \frac{eE}{m} = \frac{eV}{Rm} \quad \text{Now, } V^2 = 2 \times a \times S \quad [\because x = 0]$$

$$V = \sqrt{\frac{2 \times e \times V \times R}{Rm}} = \sqrt{\frac{2eV}{m}}$$

$$\text{Time taken by particle to cover the arc} = \frac{2\pi m}{qB} = \frac{2\pi m}{eB}$$

Since the acceleration is along 'Y' axis.

Hence it travels along x axis in uniform velocity

$$\text{Therefore, } x = v \times t = \sqrt{\frac{2em}{m}} \times \frac{2\pi m}{eB} = \sqrt{\frac{8\pi^2 mV}{eB^2}}$$

45. (a) The particulars will not collide if

$$d = r_1 + r_2$$

$$\Rightarrow d = \frac{mV_m}{qB} + \frac{mV_m}{qB}$$

$$\Rightarrow d = \frac{2mV_m}{qB} \Rightarrow V_m = \frac{qBd}{2m}$$

$$\text{(b) } V = \frac{V_m}{2}$$

$$d_1' = r_1 + r_2 = 2 \left(\frac{m \times qBd}{2 \times 2m \times qB} \right) = \frac{d}{2} \text{ (min. dist.)}$$

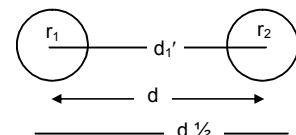
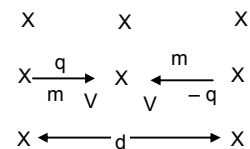
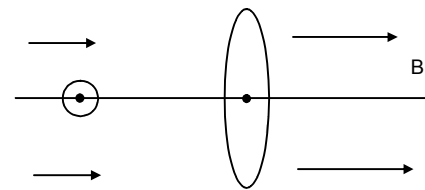

Max. distance $d_2' = d + 2r = d + \frac{d}{2} = \frac{3d}{2}$

(c) $V = 2V_m$

$r_1' = \frac{m_2 V_m}{qB} = \frac{m \times 2 \times qBd}{2n \times qB}$, $r_2 = d$ \therefore The arc is $1/6$

(d) $V_m = \frac{qBd}{2m}$

The particles will collide at point P. At point p, both the particles will have motion m in upward direction. Since the particles collide inelastically the stick together.

Distance l between centres = d, $\sin \theta = \frac{l}{2r}$

Velocity upward = $v \cos 90 - \theta = V \sin \theta = \frac{Vl}{2r}$

$\frac{mv^2}{r} = qvB \Rightarrow r = \frac{mv}{qB}$

$V \sin \theta = \frac{vl}{2r} = \frac{vl}{2 \frac{mv}{qB}} = \frac{qBd}{2m} = V_m$

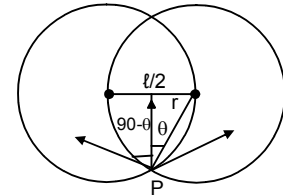

Hence the combined mass will move with velocity V_m

46. $B = 0.20 \text{ T}$, $v = ?$ $m = 0.010\text{g} = 10^{-5} \text{ kg}$ $q = 1 \times 10^{-5} \text{ C}$

Force due to magnetic field = Gravitational force of attraction

So, $qvB = mg$

$\Rightarrow 1 \times 10^{-5} \times v \times 2 \times 10^{-1} = 1 \times 10^{-5} \times 9.8$

$\Rightarrow v = \frac{9.8 \times 10^{-5}}{2 \times 10^{-6}} = 49 \text{ m/s.}$

47. $r = 0.5 \text{ cm} = 0.5 \times 10^{-2} \text{ m}$

$B = 0.4 \text{ T}$, $E = 200 \text{ V/m}$

The path will straighten, if $qE = qvB \Rightarrow E = \frac{rqB \times B}{m}$ [$\therefore r = \frac{mv}{qB}$]

$\Rightarrow E = \frac{rqB^2}{m} \Rightarrow \frac{q}{m} = \frac{E}{B^2 r} = \frac{200}{0.4 \times 0.4 \times 0.5 \times 10^{-2}} = 2.5 \times 10^5 \text{ c/kg}$

48. $M_p = 1.6 \times 10^{-27} \text{ Kg}$

$v = 2 \times 10^5 \text{ m/s}$

$r = 4 \text{ cm} = 4 \times 10^{-2} \text{ m}$

Since the proton is undeflected in the combined magnetic and electric field. Hence force due to both the fields must be same.

i.e. $qE = qvB \Rightarrow E = vB$

Won, when the electricfield is stopped, then it forms a circle due to force of magnetic field

We know $r = \frac{mv}{qB}$

$\Rightarrow 4 \times 10^2 = \frac{1.6 \times 10^{-27} \times 2 \times 10^5}{1.6 \times 10^{-19} \times B}$

$\Rightarrow B = \frac{1.6 \times 10^{-27} \times 2 \times 10^5}{4 \times 10^2 \times 1.6 \times 10^{-19}} = 0.5 \times 10^{-1} = 0.005 \text{ T}$

$E = vB = 2 \times 10^5 \times 0.05 = 1 \times 10^4 \text{ N/C}$

49. $q = 5 \mu\text{F} = 5 \times 10^{-6} \text{ C}$,

$m = 5 \times 10^{-12} \text{ kg}$,

$V = 1 \text{ km/s} = 10^3 \text{ m/s}$

$\theta = \sin^{-1}(0.9)$, $B = 5 \times 10^{-3} \text{ T}$

We have $mv'^2 = qv'B$

$r = \frac{mv'}{qB} = \frac{mv \sin \theta}{qB} = \frac{5 \times 10^{-12} \times 10^3 \times 9}{5 \times 10^{-6} + 5 \times 10^3 + 10} = 0.18 \text{ metre}$

Hence diameter = 36 cm.,

$$\text{Pitch} = \frac{2\pi r}{v \sin \theta} v \cos \theta = \frac{2 \times 3.1416 \times 0.1 \times \sqrt{1-0.51}}{0.9} = 0.54 \text{ metre} = 54 \text{ mc.}$$

The velocity has a x-component along with which no force acts so that the particle, moves with uniform velocity. The velocity has a y-component with which it accelerates with acceleration a. with the Vertical component it moves in a circular crosssection. Thus it moves in a helix.

50. $\vec{B} = 0.020 \text{ T}$ $M_p = 1.6 \times 10^{-27} \text{ Kg}$

Pitch = 20 cm = $2 \times 10^{-1} \text{ m}$

Radius = 5 cm = $5 \times 10^{-2} \text{ m}$

We know for a helical path, the velocity of the proton has got two components θ_{\perp} & θ_H

$$\text{Now, } r = \frac{m\theta_{\perp}}{qB} \Rightarrow 5 \times 10^{-2} = \frac{1.6 \times 10^{-27} \times \theta_{\perp}}{1.6 \times 10^{-19} \times 2 \times 10^{-2}}$$

$$\Rightarrow \theta_{\perp} = \frac{5 \times 10^{-2} \times 1.6 \times 10^{-19} \times 2 \times 10^{-2}}{1.6 \times 10^{-27}} = 1 \times 10^5 \text{ m/s}$$

However, θ_H remains constant

$$T = \frac{2\pi m}{qB}$$

$$\text{Pitch} = \theta_H \times T \text{ or, } \theta_H = \frac{\text{Pitch}}{T}$$

$$\theta_H = \frac{2 \times 10^{-1}}{2 \times 3.14 \times 1.6 \times 10^{-27}} \times 1.6 \times 10^{-19} \times 2 \times 10^{-2} = 0.6369 \times 10^5 \approx 6.4 \times 10^4 \text{ m/s}$$

51. Velocity will be along x – z plane

$$\vec{B} = -B_0 \hat{j} \quad \vec{E} = E_0 \hat{k}$$

$$F = q (\vec{E} + \vec{v} \times \vec{B}) = q [E_0 \hat{k} + (u_x \hat{i} + u_x \hat{k})(-B_0 \hat{j})] = (qE_0) \hat{k} - (u_x B_0) \hat{k} + (u_z B_0) \hat{i}$$

$$F_z = (qE_0 - u_x B_0)$$

$$\text{Since } u_x = 0, F_z = qE_0$$

$$\Rightarrow a_z = \frac{qE_0}{m}, \text{ So, } v^2 = u^2 + 2as \Rightarrow v^2 = 2 \frac{qE_0}{m} Z \text{ [distance along Z direction be z]}$$

$$\Rightarrow V = \sqrt{\frac{2qE_0 Z}{m}}$$

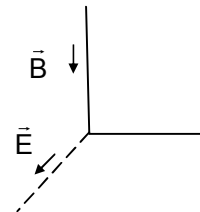

52. The force experienced first is due to the electric field due to the capacitor

$$E = \frac{V}{d} \quad F = eE$$

$$a = \frac{eE}{m_e} \quad [\text{Where } e \rightarrow \text{charge of electron } m_e \rightarrow \text{mass of electron}]$$

$$v^2 = u^2 + 2as \Rightarrow v^2 = 2 \times \frac{eE}{m_e} \times d = \frac{2 \times e \times V \times d}{dm_e}$$

$$\text{or } v = \sqrt{\frac{2eV}{m_e}}$$

Now, The electron will fail to strike the upper plate only when d is greater than radius of the are thus formed.

$$\text{or, } d > \frac{m_e \times \sqrt{\frac{2eV}{m_e}}}{eB} \Rightarrow d > \frac{\sqrt{2m_e V}}{eB^2}$$

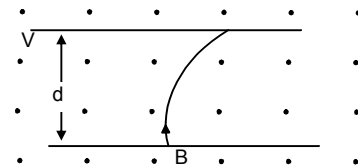

53. $\tau = ni \vec{A} \times \vec{B}$

$$\Rightarrow \tau = ni AB \sin 90^\circ \Rightarrow 0.2 = 100 \times 2 \times 5 \times 4 \times 10^{-4} \times B$$

$$\Rightarrow B = \frac{0.2}{100 \times 2 \times 5 \times 4 \times 10^{-4}} = 0.5 \text{ Tesla}$$

54. $n = 50, r = 0.02 \text{ m}$

$A = \pi \times (0.02)^2, \quad B = 0.02 \text{ T}$

$i = 5 \text{ A}, \quad \mu = niA = 50 \times 5 \times \pi \times 4 \times 10^{-4}$

τ is max. when $\theta = 90^\circ$

$\tau = \mu \times B = \mu B \sin 90^\circ = \mu B = 50 \times 5 \times 3.14 \times 4 \times 10^{-4} \times 2 \times 10^{-1} = 6.28 \times 10^{-2} \text{ N-M}$

Given $\tau = (1/2) \tau_{\text{max}}$

$\Rightarrow \sin \theta = (1/2)$

or, $\theta = 30^\circ = \text{Angle between area vector \& magnetic field.}$

$\Rightarrow \text{Angle between magnetic field and the plane of the coil} = 90^\circ - 30^\circ = 60^\circ$

55. $l = 20 \text{ cm} = 20 \times 10^{-2} \text{ m}$

$B = 10 \text{ cm} = 10 \times 10^{-2} \text{ m}$

$i = 5 \text{ A}, \quad B = 0.2 \text{ T}$

(a) There is no force on the sides AB and CD. But the force on the sides AD and BC are opposite. So they cancel each other.

(b) Torque on the loop

$\tau = ni \vec{A} \times \vec{B} = niAB \sin 90^\circ$

$= 1 \times 5 \times 20 \times 10^{-2} \times 10 \times 10^{-2} \times 0.2 = 2 \times 10^{-2} = 0.02 \text{ N-M}$

Parallel to the shorter side.

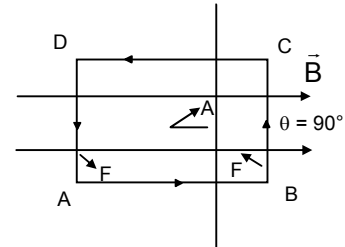

56. $n = 500, \quad r = 0.02 \text{ m}, \quad \theta = 30^\circ$

$i = 1 \text{ A}, \quad B = 4 \times 10^{-1} \text{ T}$

$i = \mu \times B = \mu B \sin 30^\circ = niAB \sin 30^\circ$

$= 500 \times 1 \times 3.14 \times 4 \times 10^{-4} \times 4 \times 10^{-1} \times (1/2) = 12.56 \times 10^{-2} = 0.1256 \approx 0.13 \text{ N-M}$

57. (a) radius = r

Circumference = $L = 2\pi r$

$\Rightarrow r = \frac{L}{2\pi}$

$\Rightarrow \pi r^2 = \frac{\pi L^2}{4\pi^2} = \frac{L^2}{4\pi}$

$\tau = i \vec{A} \times \vec{B} = \frac{iL^2B}{4\pi}$

(b) Circumference = L

$4S = L \Rightarrow S = \frac{L}{4}$

Area = $S^2 = \left(\frac{L}{4}\right)^2 = \frac{L^2}{16}$

$\tau = i \vec{A} \times \vec{B} = \frac{iL^2B}{16}$

58. Edge = l, Current = i Turns = n, mass = M

Magnetic field = B

$\tau = \mu B \sin 90^\circ = \mu B$

Min Torque produced must be able to balance the torque produced due to weight

Now, $\tau B = \tau \text{ Weight}$

$\mu B = \mu g \left(\frac{l}{2}\right) \Rightarrow n \times i \times l^2 B = \mu g \left(\frac{l}{2}\right) \Rightarrow B = \frac{\mu g}{2nil}$

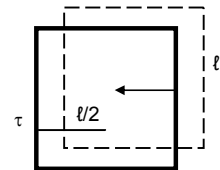

59. (a) $i = \frac{q}{t} = \frac{q}{(2\pi/\omega)} = \frac{q\omega}{2\pi}$

(b) $\mu = n i a = i A [\because n = 1] = \frac{q\omega\pi r^2}{2\pi} = \frac{q\omega r^2}{2}$

(c) $\mu = \frac{q\omega r^2}{2}, L = I\omega = mr^2\omega, \frac{\mu}{L} = \frac{q\omega r^2}{2mr^2\omega} = \frac{q}{2m} \Rightarrow \mu = \left(\frac{q}{2m}\right)L$

60. dp on the small length dx is $\frac{q}{\pi r^2} 2\pi x dx$.

$$di = \frac{q2\pi \times dx}{\pi r^2 t} = \frac{q2\pi x dx \omega}{\pi r^2 q 2\pi} = \frac{q\omega}{\pi r^2} x dx$$

$$d\mu = n di A = di A = \frac{q\omega x dx}{\pi r^2} \pi x^2$$

$$\mu = \int_0^r d\mu = \int_0^r \frac{q\omega}{r^2} x^3 dx = \frac{q\omega}{r^2} \left[\frac{x^4}{4} \right]_0^r = \frac{q\omega r^4}{r^2 \times 4} = \frac{q\omega r^2}{4}$$

$$I = I \omega = (1/2) m r^2 \omega \quad [\because \text{M.I. for disc is } (1/2) m r^2]$$

$$\frac{\mu}{I} = \frac{q\omega r^2}{4 \times \left(\frac{1}{2}\right) m r^2 \omega} \Rightarrow \frac{\mu}{I} = \frac{q}{2m} \Rightarrow \mu = \frac{q}{2m} I$$

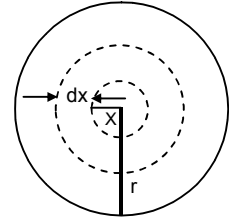

61. Considering a strip of width dx at a distance x from centre,

$$dq = \frac{q}{\left(\frac{4}{3}\right)\pi R^3} 4\pi x^2 dx$$

$$di = \frac{dq}{dt} = \frac{q4\pi x^2 dx}{\left(\frac{4}{3}\right)\pi R^3 t} = \frac{3qx^2 dx \omega}{R^3 2\pi}$$

$$d\mu = di \times A = \frac{3qx^2 dx \omega}{R^3 2\pi} \times 4\pi x^2 = \frac{6q\omega}{R^3} x^4 dx$$

$$\mu = \int_0^R d\mu = \int_0^R \frac{6q\omega}{R^3} x^4 dx = \frac{6q\omega}{R^3} \left[\frac{x^5}{5} \right]_0^R = \frac{6q\omega R^5}{R^3 \times 5} = \frac{6}{5} q\omega R^2$$

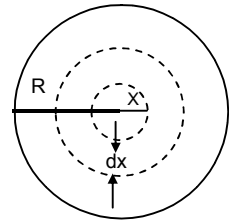

CHAPTER – 35 MAGNETIC FIELD DUE TO CURRENT

1. $F = q\vec{v} \times \vec{B}$ or, $B = \frac{F}{qv} = \frac{F}{ITv} = \frac{N}{A \cdot \text{sec.} / \text{sec.}} = \frac{N}{A \cdot \text{m}}$

$$B = \frac{\mu_0 I}{2\pi r} \quad \text{or, } \mu_0 = \frac{2\pi r B}{I} = \frac{\text{m} \times \text{N}}{\text{A} \cdot \text{m} \times \text{A}} = \frac{\text{N}}{\text{A}^2}$$

2. $i = 10 \text{ A}, \quad d = 1 \text{ m}$

$$B = \frac{\mu_0 i}{2\pi r} = \frac{10^{-7} \times 4\pi \times 10}{2\pi \times 1} = 20 \times 10^{-6} \text{ T} = 2 \mu\text{T}$$

Along +ve Y direction.

3. $d = 1.6 \text{ mm}$

So, $r = 0.8 \text{ mm} = 0.0008 \text{ m}$

$i = 20 \text{ A}$

$$\vec{B} = \frac{\mu_0 i}{2\pi r} = \frac{4\pi \times 10^{-7} \times 20}{2 \times \pi \times 8 \times 10^{-4}} = 5 \times 10^{-3} \text{ T} = 5 \text{ mT}$$

4. $i = 100 \text{ A}, \quad d = 8 \text{ m}$

$$B = \frac{\mu_0 i}{2\pi r} = \frac{4\pi \times 10^{-7} \times 100}{2 \times \pi \times 8} = 2.5 \mu\text{T}$$

5. $\mu_0 = 4\pi \times 10^{-7} \text{ T-m/A}$

$r = 2 \text{ cm} = 0.02 \text{ m}, \quad I = 1 \text{ A}, \quad \vec{B} = 1 \times 10^{-5} \text{ T}$

We know: Magnetic field due to a long straight wire carrying current = $\frac{\mu_0 I}{2\pi r}$

$$\vec{B} \text{ at P} = \frac{4\pi \times 10^{-7} \times 1}{2\pi \times 0.02} = 1 \times 10^{-5} \text{ T upward}$$

net $B = 2 \times 1 \times 10^{-5} \text{ T} = 20 \mu\text{T}$

$B \text{ at Q} = 1 \times 10^{-5} \text{ T downwards}$

Hence net $\vec{B} = 0$

6. (a) The maximum magnetic field is $B + \frac{\mu_0 I}{2\pi r}$ which are along the left keeping the sense along the direction of traveling current.

(b) The minimum $B - \frac{\mu_0 I}{2\pi r}$

If $r = \frac{\mu_0 I}{2\pi B}$ B net = 0

$r < \frac{\mu_0 I}{2\pi B}$ B net = 0

$r > \frac{\mu_0 I}{2\pi B}$ B net = $B - \frac{\mu_0 I}{2\pi r}$

7. $\mu_0 = 4\pi \times 10^{-7} \text{ T-m/A}, \quad I = 30 \text{ A}, \quad B = 4.0 \times 10^{-4} \text{ T Parallel to current.}$

\vec{B} due to wire at a pt. 2 cm

$$= \frac{\mu_0 I}{2\pi r} = \frac{4\pi \times 10^{-7} \times 30}{2\pi \times 0.02} = 3 \times 10^{-4} \text{ T}$$

net field = $\sqrt{(3 \times 10^{-4})^2 + (4 \times 10^{-4})^2} = 5 \times 10^{-4} \text{ T}$

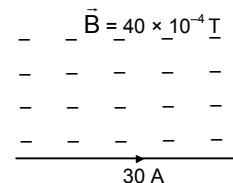
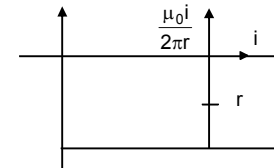
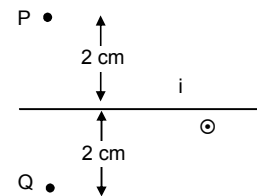
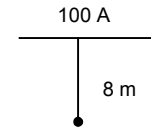
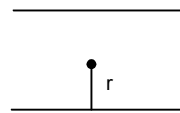
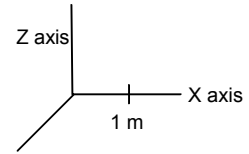

8. $i = 10 \text{ A. } (\hat{K})$

$B = 2 \times 10^{-3} \text{ T South to North } (\hat{J})$

To cancel the magnetic field the point should be chosen so that the net magnetic field is along $-\hat{J}$ direction.

∴ The point is along $-\hat{i}$ direction or along west of the wire.

$$B = \frac{\mu_0 I}{2\pi r}$$

$$\Rightarrow 2 \times 10^{-3} = \frac{4\pi \times 10^{-7} \times 10}{2\pi \times r}$$

$$\Rightarrow r = \frac{2 \times 10^{-7}}{2 \times 10^{-3}} = 10^{-3} \text{ m} = 1 \text{ mm.}$$

9. Let the two wires be positioned at O & P

$$R = OA, = \sqrt{(0.02)^2 + (0.02)^2} = \sqrt{8 \times 10^{-4}} = 2.828 \times 10^{-2} \text{ m}$$

(a) \vec{B} due to Q, at $A_1 = \frac{4\pi \times 10^{-7} \times 10}{2\pi \times 0.02} = 1 \times 10^{-4} \text{ T } (\perp \text{r towards up the line})$

\vec{B} due to P, at $A_1 = \frac{4\pi \times 10^{-7} \times 10}{2\pi \times 0.06} = 0.33 \times 10^{-4} \text{ T } (\perp \text{r towards down the line})$

net $\vec{B} = 1 \times 10^{-4} - 0.33 \times 10^{-4} = 0.67 \times 10^{-4} \text{ T}$

(b) \vec{B} due to O at $A_2 = \frac{2 \times 10^{-7} \times 10}{0.01} = 2 \times 10^{-4} \text{ T } \perp \text{r down the line}$

\vec{B} due to P at $A_2 = \frac{2 \times 10^{-7} \times 10}{0.03} = 0.67 \times 10^{-4} \text{ T } \perp \text{r down the line}$

net \vec{B} at $A_2 = 2 \times 10^{-4} + 0.67 \times 10^{-4} = 2.67 \times 10^{-4} \text{ T}$

(c) \vec{B} at A_3 due to O = $1 \times 10^{-4} \text{ T } \perp \text{r towards down the line}$

\vec{B} at A_3 due to P = $1 \times 10^{-4} \text{ T } \perp \text{r towards down the line}$

Net \vec{B} at $A_3 = 2 \times 10^{-4} \text{ T}$

(d) \vec{B} at A_4 due to O = $\frac{2 \times 10^{-7} \times 10}{2.828 \times 10^{-2}} = 0.7 \times 10^{-4} \text{ T } \text{ towards SE}$

\vec{B} at A_4 due to P = $0.7 \times 10^{-4} \text{ T } \text{ towards SW}$

Net $\vec{B} = \sqrt{(0.7 \times 10^{-4})^2 + (0.7 \times 10^{-4})^2} = 0.989 \times 10^{-4} \approx 1 \times 10^{-4} \text{ T}$

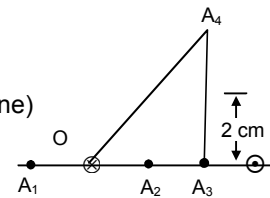

10. $\cos \theta = \frac{1}{2}, \theta = 60^\circ \text{ \& } \angle AOB = 60^\circ$

$$B = \frac{\mu_0 I}{2\pi r} = \frac{10^{-7} \times 2 \times 10}{2 \times 10^{-2}} = 10^{-4} \text{ T}$$

So net is $[(10^{-4})^2 + (10^{-4})^2 + 2(10^{-8}) \cos 60^\circ]^{1/2}$
 $= 10^{-4} [1 + 1 + 2 \times \frac{1}{2}]^{1/2} = 10^{-4} \times \sqrt{3} \text{ T} = 1.732 \times 10^{-4} \text{ T}$

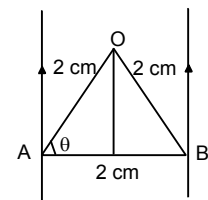

11. (a) \vec{B} for X = \vec{B} for Y

Both are oppositely directed hence net $\vec{B} = 0$

(b) \vec{B} due to X = \vec{B} due to Y both directed along Z-axis

$$\text{Net } \vec{B} = \frac{2 \times 10^{-7} \times 2 \times 5}{1} = 2 \times 10^{-6} \text{ T} = 2 \mu\text{T}$$

(c) \vec{B} due to X = \vec{B} due to Y both directed opposite to each other.

Hence Net $\vec{B} = 0$

(d) \vec{B} due to X = \vec{B} due to Y = $1 \times 10^{-6} \text{ T}$ both directed along $(-)$ ve Z-axis

Hence Net $\vec{B} = 2 \times 1.0 \times 10^{-6} = 2 \mu\text{T}$

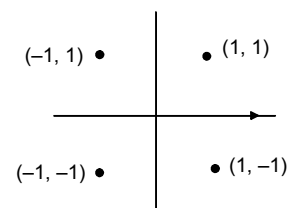

12. (a) For each of the wire

Magnitude of magnetic field

$$= \frac{\mu_0 i}{4\pi r} (\sin 45^\circ + \sin 45^\circ) = \frac{\mu_0 \times 5}{4\pi \times (5/2)} \frac{2}{\sqrt{2}}$$

For AB \odot for BC \odot For CD \otimes and for DA \otimes .

The two \odot and $2\otimes$ fields cancel each other. Thus $B_{\text{net}} = 0$

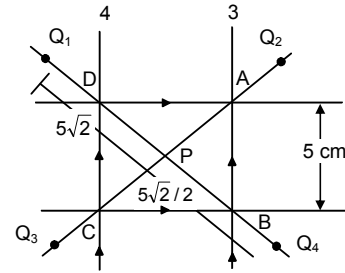

(b) At point Q_1

$$\text{due to (1)} B = \frac{\mu_0 i}{2\pi \times 2.5 \times 10^{-2}} = \frac{4\pi \times 5 \times 2 \times 10^{-7}}{2\pi \times 5 \times 10^{-2}} = 4 \times 10^{-5} \odot$$

$$\text{due to (2)} B = \frac{\mu_0 i}{2\pi \times (15/2) \times 10^{-2}} = \frac{4\pi \times 5 \times 2 \times 10^{-7}}{2\pi \times 15 \times 10^{-2}} = (4/3) \times 10^{-5} \odot$$

$$\text{due to (3)} B = \frac{\mu_0 i}{2\pi \times (5 + 5/2) \times 10^{-2}} = \frac{4\pi \times 5 \times 2 \times 10^{-7}}{2\pi \times 15 \times 10^{-2}} = (4/3) \times 10^{-5} \odot$$

$$\text{due to (4)} B = \frac{\mu_0 i}{2\pi \times 2.5 \times 10^{-2}} = \frac{4\pi \times 5 \times 2 \times 10^{-7}}{2\pi \times 5 \times 10^{-2}} = 4 \times 10^{-5} \odot$$

$$B_{\text{net}} = [4 + 4 + (4/3) + (4/3)] \times 10^{-5} = \frac{32}{3} \times 10^{-5} = 10.6 \times 10^{-5} \approx 1.1 \times 10^{-4} \text{ T}$$

At point Q_2

$$\text{due to (1)} \frac{\mu_0 i}{2\pi \times (2.5) \times 10^{-2}} \odot$$

$$\text{due to (2)} \frac{\mu_0 i}{2\pi \times (15/2) \times 10^{-2}} \odot$$

$$\text{due to (3)} \frac{\mu_0 i}{2\pi \times (2.5) \times 10^{-2}} \otimes$$

$$\text{due to (4)} \frac{\mu_0 i}{2\pi \times (15/2) \times 10^{-2}} \otimes$$

$B_{\text{net}} = 0$

At point Q_3

$$\text{due to (1)} \frac{4\pi \times 10^{-7} \times 5}{2\pi \times (15/2) \times 10^{-2}} = 4/3 \times 10^{-5} \otimes$$

$$\text{due to (2)} \frac{4\pi \times 10^{-7} \times 5}{2\pi \times (5/2) \times 10^{-2}} = 4 \times 10^{-5} \otimes$$

$$\text{due to (3)} \frac{4\pi \times 10^{-7} \times 5}{2\pi \times (5/2) \times 10^{-2}} = 4 \times 10^{-5} \otimes$$

$$\text{due to (4)} \frac{4\pi \times 10^{-7} \times 5}{2\pi \times (15/2) \times 10^{-2}} = 4/3 \times 10^{-5} \otimes$$

$$B_{\text{net}} = [4 + 4 + (4/3) + (4/3)] \times 10^{-5} = \frac{32}{3} \times 10^{-5} = 10.6 \times 10^{-5} \approx 1.1 \times 10^{-4} \text{ T}$$

For Q_4

$$\text{due to (1)} 4/3 \times 10^{-5} \otimes$$

$$\text{due to (2)} 4 \times 10^{-5} \otimes$$

$$\text{due to (3)} 4/3 \times 10^{-5} \otimes$$

$$\text{due to (4)} 4 \times 10^{-5} \otimes$$

$B_{\text{net}} = 0$

13. Since all the points lie along a circle with radius = 'd'
Hence 'R' & 'Q' both at a distance 'd' from the wire.
So, magnetic field \vec{B} due to are same in magnitude.
As the wires can be treated as semi infinite straight current carrying conductors. Hence magnetic field $\vec{B} = \frac{\pi_0 i}{4\pi d}$

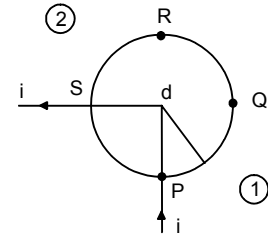

At P

B_1 due to 1 is 0

B_2 due to 2 is $\frac{\pi_0 i}{4\pi d}$

At Q

B_1 due to 1 is $\frac{\pi_0 i}{4\pi d}$

B_2 due to 2 is 0

At R

B_1 due to 1 is 0

B_2 due to 2 is $\frac{\pi_0 i}{4\pi d}$

At S

B_1 due to 1 is $\frac{\pi_0 i}{4\pi d}$

B_2 due to 2 is 0

14. $B = \frac{\pi_0 i}{4\pi d} 2 \sin \theta$
 $= \frac{\pi_0 i}{4\pi d} \frac{2 \times x}{2 \times \sqrt{d^2 + \frac{x^2}{4}}} = \frac{\mu_0 i x}{4\pi d \sqrt{d^2 + \frac{x^2}{4}}}$

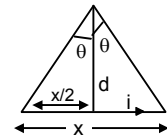

(a) When $d \gg x$

Neglecting x w.r.t. d

$$B = \frac{\mu_0 i x}{\mu \pi d \sqrt{d^2}} = \frac{\mu_0 i x}{\mu \pi d^2}$$

$$\therefore B \propto \frac{1}{d^2}$$

(b) When $x \gg d$, neglecting d w.r.t. x

$$B = \frac{\mu_0 i x}{4\pi d x / 2} = \frac{2\mu_0 i}{4\pi d}$$

$$\therefore B \propto \frac{1}{d}$$

15. $I = 10 \text{ A}$, $a = 10 \text{ cm} = 0.1 \text{ m}$

$$r = OP = \frac{\sqrt{3}}{2} \times 0.1 \text{ m}$$

$$B = \frac{\mu_0 I}{4\pi r} (\sin \phi_1 + \sin \phi_2)$$

$$= \frac{10^{-7} \times 10 \times 1}{\frac{\sqrt{3}}{2} \times 0.1} = \frac{2 \times 10^{-5}}{1.732} = 1.154 \times 10^{-5} \text{ T} = 11.54 \mu\text{T}$$

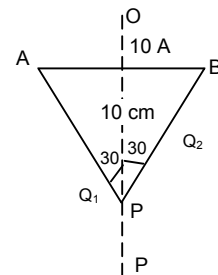

$$16. B_1 = \frac{\mu_0 i}{2\pi d}, \quad B_2 = \frac{\mu_0 i}{4\pi d} (2 \times \sin\theta) = \frac{\mu_0 i}{4\pi d} \frac{2 \times \ell}{2\sqrt{d^2 + \frac{\ell^2}{4}}} = \frac{\mu_0 i \ell}{4\pi d \sqrt{d^2 + \frac{\ell^2}{4}}}$$

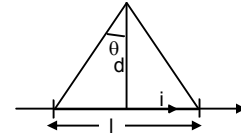

$$B_1 - B_2 = \frac{1}{100} B_2 \Rightarrow \frac{\mu_0 i}{2\pi d} - \frac{\mu_0 i \ell}{4\pi d \sqrt{d^2 + \frac{\ell^2}{4}}} = \frac{\mu_0 i}{200\pi d}$$

$$\Rightarrow \frac{\mu_0 i \ell}{4\pi d \sqrt{d^2 + \frac{\ell^2}{4}}} = \frac{\mu_0 i}{\pi d} \left(\frac{1}{2} - \frac{1}{200} \right)$$

$$\Rightarrow \frac{\ell}{4\sqrt{d^2 + \frac{\ell^2}{4}}} = \frac{99}{200} \quad \Rightarrow \frac{\ell^2}{d^2 + \frac{\ell^2}{4}} = \left(\frac{99 \times 4}{200} \right)^2 = \frac{156816}{40000} = 3.92$$

$$\Rightarrow \ell^2 = 3.92 d^2 + \frac{3.92}{4} \ell^2$$

$$\left(\frac{1 - 3.92}{4} \right) \ell^2 = 3.92 d^2 \Rightarrow 0.02 \ell^2 = 3.92 d^2 \Rightarrow \frac{d^2}{\ell^2} = \frac{0.02}{3.92} = \frac{d}{\ell} = \sqrt{\frac{0.02}{3.92}} = 0.07$$

17. As resistances vary as r & $2r$

Hence Current along ABC = $\frac{i}{3}$ & along ADC = $\frac{2}{3}i$

Now,

$$\vec{B} \text{ due to ADC} = 2 \left[\frac{\mu_0 i \times 2 \times 2 \times \sqrt{2}}{4\pi 3a} \right] = \frac{2\sqrt{2}\mu_0 i}{3\pi a}$$

$$\vec{B} \text{ due to ABC} = 2 \left[\frac{\mu_0 i \times 2 \times \sqrt{2}}{4\pi 3a} \right] = \frac{2\sqrt{2}\mu_0 i}{6\pi a}$$

$$\text{Now } \vec{B} = \frac{2\sqrt{2}\mu_0 i}{3\pi a} - \frac{2\sqrt{2}\mu_0 i}{6\pi a} = \frac{\sqrt{2}\mu_0 i}{3\pi a} \quad \otimes$$

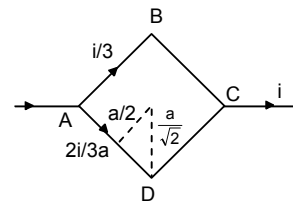

$$18. A_0 = \sqrt{\frac{a^2}{16} + \frac{a^2}{4}} = \sqrt{\frac{5a^2}{16}} = \frac{a\sqrt{5}}{4}$$

$$D_0 = \sqrt{\left(\frac{3a}{4} \right)^2 + \left(\frac{a}{2} \right)^2} = \sqrt{\frac{9a^2}{16} + \frac{a^2}{4}} = \sqrt{\frac{13a^2}{16}} = \frac{a\sqrt{13}}{4}$$

Magnetic field due to AB

$$B_{AB} = \frac{\mu_0}{4\pi} \times \frac{i}{2(a/4)} (\sin(90 - \alpha) + \sin(90 - \alpha))$$

$$= \frac{\mu_0 \times 2i}{4\pi a} 2\cos\alpha = \frac{\mu_0 \times 2i}{4\pi a} \times 2 \times \frac{(a/2)}{a(\sqrt{5}/4)} = \frac{2\mu_0 i}{\pi\sqrt{5}}$$

Magnetic field due to DC

$$B_{DC} = \frac{\mu_0}{4\pi} \times \frac{i}{2(3a/4)} 2\sin(90 - \alpha)$$

$$= \frac{\mu_0 i \times 4 \times 2}{4\pi \times 3a} \cos\beta = \frac{\mu_0 i}{\pi \times 3a} \times \frac{(a/2)}{(\sqrt{13}a/4)} = \frac{2\mu_0 i}{\pi a 3\sqrt{13}}$$

The magnetic field due to AD & BC are equal and appropriate hence cancel each other.

$$\text{Hence, net magnetic field is } \frac{2\mu_0 i}{\pi\sqrt{5}} - \frac{2\mu_0 i}{\pi a 3\sqrt{13}} = \frac{2\mu_0 i}{\pi a} \left[\frac{1}{\sqrt{5}} - \frac{1}{3\sqrt{13}} \right]$$

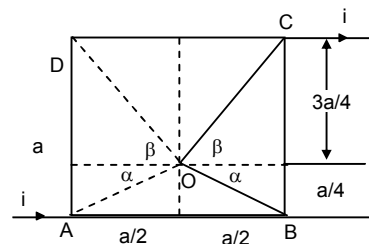

19. \vec{B} due to BC & \vec{B} due to AD at Pt 'P' are equal or Opposite
Hence net $\vec{B} = 0$
Similarly, due to AB & CD at P = 0
 \therefore The net \vec{B} at the Centre of the square loop = zero.

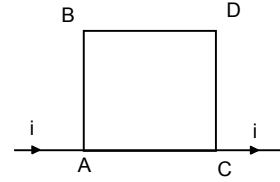

20. For AB B is along \odot $B = \frac{\mu_0 i}{4\pi r} (\sin 60^\circ + \sin 60^\circ)$
For AC B \otimes $B = \frac{\mu_0 i}{4\pi r} (\sin 60^\circ + \sin 60^\circ)$
For BD B \odot $B = \frac{\mu_0 i}{4\pi r} (\sin 60^\circ)$
For DC B \otimes $B = \frac{\mu_0 i}{4\pi r} (\sin 60^\circ)$
 \therefore Net $B = 0$

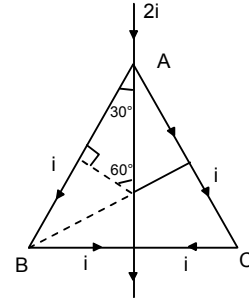

21. (a) ΔABC is Equilateral
 $AB = BC = CA = l/3$
Current = i

$$AO = \frac{\sqrt{3}}{2} a = \frac{\sqrt{3} \times l}{2 \times 3} = \frac{l}{2\sqrt{3}}$$

$$\phi_1 = \phi_2 = 60^\circ$$

$$\text{So, } MO = \frac{l}{6\sqrt{3}} \quad \text{as } AM : MO = 2 : 1$$

\vec{B} due to BC at \odot .

$$= \frac{\mu_0 i}{4\pi r} (\sin \phi_1 + \sin \phi_2) = \frac{\mu_0 i}{4\pi} \times i \times 6\sqrt{3} \times \sqrt{3} = \frac{\mu_0 i \times 9}{2\pi l}$$

$$\text{net } \vec{B} = \frac{9\mu_0 i}{2\pi l} \times 3 = \frac{27\mu_0 i}{2\pi l}$$

$$(b) \vec{B} \text{ due to AD} = \frac{\mu_0 i \times 8}{4\pi \times l} \sqrt{2} = \frac{8\sqrt{2}\mu_0 i}{4\pi l}$$

$$\text{Net } \vec{B} = \frac{8\sqrt{2}\mu_0 i}{4\pi l} \times 4 = \frac{8\sqrt{2}\mu_0 i}{\pi l}$$

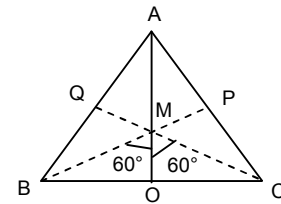

22. $\sin(\alpha/2) = \frac{r}{x}$

$$\Rightarrow r = x \sin(\alpha/2)$$

Magnetic field B due to AR

$$\frac{\mu_0 i}{4\pi r} [\sin(180 - (90 - (\alpha/2))) + 1]$$

$$\Rightarrow \frac{\mu_0 i [\sin(90 - (\alpha/2)) + 1]}{4\pi \times \sin(\alpha/2)}$$

$$= \frac{\mu_0 i (\cos(\alpha/2) + 1)}{4\pi \times \sin(\alpha/2)}$$

$$= \frac{\mu_0 i 2\cos^2(\alpha/4)}{4\pi \times 2\sin(\alpha/4)\cos(\alpha/4)} = \frac{\mu_0 i}{4\pi x} \cot(\alpha/4)$$

The magnetic field due to both the wire.

$$\frac{2\mu_0 i}{4\pi x} \cot(\alpha/4) = \frac{\mu_0 i}{2\pi x} \cot(\alpha/4)$$

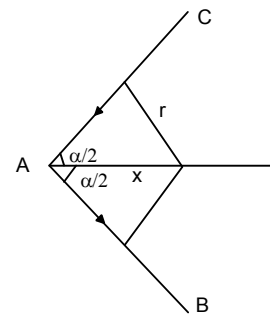
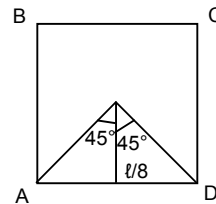

23. \vec{B}_{AB}

$$\frac{\mu_0 i \times 2}{4\pi b} \times 2\sin\theta = \frac{\mu_0 i \sin\theta}{\pi b}$$

$$= \frac{\mu_0 i \ell}{\pi b \sqrt{\ell^2 + b^2}} = \vec{B}_{DC}$$

$$\therefore \sin(\ell^2 + b^2) = \frac{(\ell/2)}{\sqrt{\ell^2/4 + b^2/4}} = \frac{\ell}{\sqrt{\ell^2 + b^2}}$$

\vec{B}_{BC}

$$\frac{\mu_0 i \times 2}{4\pi \ell} \times 2 \times 2\sin\theta' = \frac{\mu_0 i \sin\theta'}{\pi \ell}$$

$$\therefore \sin\theta' = \frac{(b/2)}{\sqrt{\ell^2/4 + b^2/4}} = \frac{b}{\sqrt{\ell^2 + b^2}}$$

$$= \frac{\mu_0 i b}{\pi \ell \sqrt{\ell^2 + b^2}} = \vec{B}_{AD}$$

$$\text{Net } \vec{B} = \frac{2\mu_0 i \ell}{\pi b \sqrt{\ell^2 + b^2}} + \frac{2\mu_0 i b}{\pi \ell \sqrt{\ell^2 + b^2}} = \frac{2\mu_0 i (\ell^2 + b^2)}{\pi \ell b \sqrt{\ell^2 + b^2}} = \frac{2\mu_0 i \sqrt{\ell^2 + b^2}}{\pi \ell b}$$

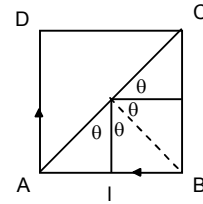

24. $2\theta = \frac{2\pi}{n} \Rightarrow \theta = \frac{\pi}{n}$,

$\ell = \frac{2\pi r}{n}$

$$\tan\theta = \frac{\ell}{2x} \Rightarrow x = \frac{\ell}{2\tan\theta}$$

$$\frac{\ell}{2} = \frac{\pi r}{n}$$

$$B_{AB} = \frac{\mu_0 i}{4\pi(x)} (\sin\theta + \sin\theta) = \frac{\mu_0 i 2\tan\theta \times 2\sin\theta}{4\pi \ell}$$

$$= \frac{\mu_0 i 2\tan(\pi/n) 2\sin(\pi/n)n}{4\pi 2\pi r} = \frac{\mu_0 i n \tan(\pi/n) \sin(\pi/n)}{2\pi^2 r}$$

For n sides, $B_{\text{net}} = \frac{\mu_0 i n \tan(\pi/n) \sin(\pi/n)}{2\pi^2 r}$

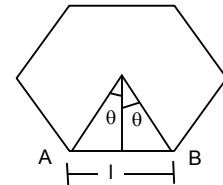

25. Net current in circuit = 0

Hence the magnetic field at point P = 0
[Owing to wheat stone bridge principle]

26. Force acting on 10 cm of wire is 2×10^{-5} N

$$\frac{dF}{dl} = \frac{\mu_0 i_1 i_2}{2\pi d}$$

$$\Rightarrow \frac{2 \times 10^{-5}}{10 \times 10^{-2}} = \frac{\mu_0 \times 20 \times 20}{2\pi d}$$

$$\Rightarrow d = \frac{4\pi \times 10^{-7} \times 20 \times 20 \times 10 \times 10^{-2}}{2\pi \times 2 \times 10^{-5}} = 400 \times 10^{-3} = 0.4 \text{ m} = 40 \text{ cm}$$

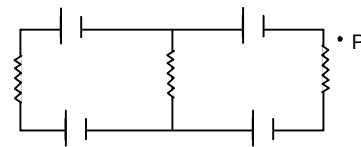

27. $i = 10$ A

Magnetic force due to two parallel Current Carrying wires.

$$F = \frac{\mu_0 I_1 I_2}{2\pi r}$$

So, \vec{F} or 1 = \vec{F} by 2 + \vec{F} by 3

$$= \frac{\mu_0 \times 10 \times 10}{2\pi \times 5 \times 10^{-2}} + \frac{\mu_0 \times 10 \times 10}{2\pi \times 10 \times 10^{-2}}$$

$$= \frac{4\pi \times 10^{-7} \times 10 \times 10}{2\pi \times 5 \times 10^{-2}} + \frac{4\pi \times 10^{-7} \times 10 \times 10}{2\pi \times 10 \times 10^{-2}}$$

$$= \frac{2 \times 10^{-3}}{5} + \frac{10^{-3}}{5} = \frac{3 \times 10^{-3}}{5} = 6 \times 10^{-4} \text{ N towards middle wire}$$

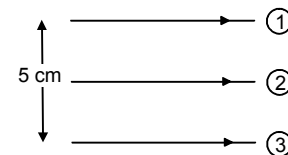
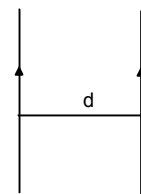

$$28. \frac{\mu_0 10i}{2\pi x} = \frac{\mu_0 i 40}{2\pi(10-x)}$$

$$\Rightarrow \frac{10}{x} = \frac{40}{10-x} \Rightarrow \frac{1}{x} = \frac{4}{10-x}$$

$$\Rightarrow 10-x = 4x \Rightarrow 5x = 10 \Rightarrow x = 2 \text{ cm}$$

The third wire should be placed 2 cm from the 10 A wire and 8 cm from 40 A wire.

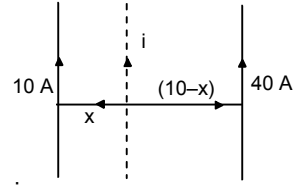

$$29. F_{AB} = F_{CD} + F_{EF}$$

$$= \frac{\mu_0 \times 10 \times 10}{2\pi \times 1 \times 10^{-2}} + \frac{\mu_0 \times 10 \times 10}{2\pi \times 2 \times 10^{-2}}$$

$$= 2 \times 10^{-3} + 10^{-3} = 3 \times 10^{-3} \quad \text{downward.}$$

$$F_{CD} = F_{AB} + F_{EF}$$

As F_{AB} & F_{EF} are equal and oppositely directed hence $F = 0$

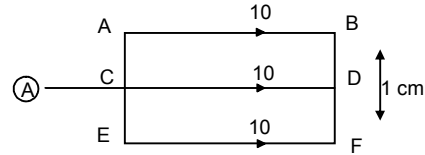

$$30. \frac{\mu_0 i_1 i_2}{2\pi d} = mg \quad (\text{For a portion of wire of length 1m})$$

$$\Rightarrow \frac{\mu_0 \times 50 \times i_2}{2\pi \times 5 \times 10^{-3}} = 1 \times 10^{-4} \times 9.8$$

$$\Rightarrow \frac{4\pi \times 10^{-7} \times 5 \times i_2}{2\pi \times 5 \times 10^{-3}} = 9.8 \times 10^{-4}$$

$$\Rightarrow 2 \times i_2 \times 10^{-3} = 9.8 \times 10^{-3} \times 10^{-1}$$

$$\Rightarrow i_2 = \frac{9.8}{2} \times 10^{-1} = 0.49 \text{ A}$$

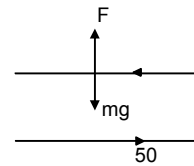

$$31. I_2 = 6 \text{ A}$$

$$I_1 = 10 \text{ A}$$

F_{PQ}

$$\text{'F' on } dx = \frac{\mu_0 i_1 i_2}{2\pi x} dx = \frac{\mu_0 i_1 i_2}{2\pi} \frac{dx}{x} = \frac{\mu_0 \times 30}{\pi} \frac{dx}{x}$$

$$\vec{F}_{PQ} = \frac{\mu_0 \times 30}{x} \int_1^3 \frac{dx}{x} = 30 \times 4 \times 10^{-7} \times [\log x]_1^2$$

$$= 120 \times 10^{-7} [\log 3 - \log 1]$$

$$\text{Similarly force of } \vec{F}_{RS} = 120 \times 10^{-7} [\log 3 - \log 1]$$

$$\text{So, } \vec{F}_{PQ} = \vec{F}_{RS}$$

$$\vec{F}_{PS} = \frac{\mu_0 \times i_1 i_2}{2\pi \times 1 \times 10^{-2}} - \frac{\mu_0 \times i_1 i_2}{2\pi \times 2 \times 10^{-2}}$$

$$= \frac{2 \times 6 \times 10 \times 10^{-7}}{10^{-2}} - \frac{2 \times 10^{-7} \times 6 \times 6}{2 \times 10^{-2}} = 8.4 \times 10^{-4} \text{ N (Towards right)}$$

$$\vec{F}_{RQ} = \frac{\mu_0 \times i_1 i_2}{2\pi \times 3 \times 10^{-2}} - \frac{\mu_0 \times i_1 i_2}{2\pi \times 2 \times 10^{-2}}$$

$$= \frac{4\pi \times 10^{-7} \times 6 \times 10}{2\pi \times 3 \times 10^{-2}} - \frac{4\pi \times 10^{-7} \times 6 \times 6}{2\pi \times 2 \times 10^{-2}} = 4 \times 10^{-4} + 36 \times 10^{-5} = 7.6 \times 10^{-4} \text{ N}$$

Net force towards down

$$= (8.4 + 7.6) \times 10^{-4} = 16 \times 10^{-4} \text{ N}$$

$$32. B = 0.2 \text{ mT}, \quad i = 5 \text{ A}, \quad n = 1, \quad r = ?$$

$$B = \frac{n\mu_0 i}{2r}$$

$$\Rightarrow r = \frac{n \times \mu_0 i}{2B} = \frac{1 \times 4\pi \times 10^{-7} \times 5}{2 \times 0.2 \times 10^{-3}} = 3.14 \times 5 \times 10^{-3} \text{ m} = 15.7 \times 10^{-3} \text{ m} = 15.7 \times 10^{-1} \text{ cm} = 1.57 \text{ cm}$$

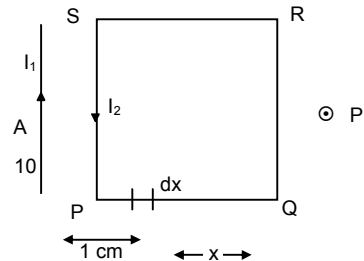

33. $B = \frac{n\mu_0 i}{2r}$
 $n = 100, \quad r = 5 \text{ cm} = 0.05 \text{ m}$
 $\vec{B} = 6 \times 10^{-5} \text{ T}$
 $i = \frac{2rB}{n\mu_0} = \frac{2 \times 0.05 \times 6 \times 10^{-5}}{100 \times 4\pi \times 10^{-7}} = \frac{3}{6.28} \times 10^{-1} = 0.0477 \approx 48 \text{ mA}$

34. 3×10^5 revolutions in 1 sec.
 1 revolutions in $\frac{1}{3 \times 10^5}$ sec

$$i = \frac{q}{t} = \frac{1.6 \times 10^{-19}}{\left(\frac{1}{3 \times 10^5}\right)} \text{ A}$$

$$B = \frac{\mu_0 i}{2r} = \frac{4\pi \times 10^{-7} \cdot 1.6 \times 10^{-19} \cdot 3 \times 10^5}{2 \times 0.5 \times 10^{-10}} \cdot \frac{2\pi \times 1.6 \times 3}{0.5} \times 10^{-11} = 6.028 \times 10^{-10} \approx 6 \times 10^{-10} \text{ T}$$

35. $I = i/2$ in each semicircle

$$ABC = \vec{B} = \frac{1}{2} \times \frac{\mu_0 (i/2)}{2a} \text{ downwards}$$

$$ADC = \vec{B} = \frac{1}{2} \times \frac{\mu_0 (i/2)}{2a} \text{ upwards}$$

Net $\vec{B} = 0$

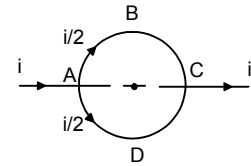

36. $r_1 = 5 \text{ cm}$ $r_2 = 10 \text{ cm}$
 $n_1 = 50$ $n_2 = 100$
 $i = 2 \text{ A}$

(a) $B = \frac{n_1 \mu_0 i}{2r_1} + \frac{n_2 \mu_0 i}{2r_2}$
 $= \frac{50 \times 4\pi \times 10^{-7} \times 2}{2 \times 5 \times 10^{-2}} + \frac{100 \times 4\pi \times 10^{-7} \times 2}{2 \times 10 \times 10^{-2}}$
 $= 4\pi \times 10^{-4} + 4\pi \times 10^{-4} = 8\pi \times 10^{-4}$

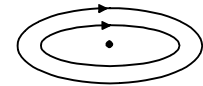

(b) $B = \frac{n_1 \mu_0 i}{2r_1} - \frac{n_2 \mu_0 i}{2r_2} = 0$

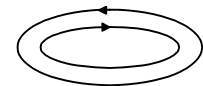

37. Outer Circle

$n = 100, \quad r = 100 \text{ m} = 0.1 \text{ m}$
 $i = 2 \text{ A}$

$$\vec{B} = \frac{n\mu_0 i}{2a} = \frac{100 \times 4\pi \times 10^{-7} \times 2}{2 \times 0.1} = 4\pi \times 10^{-4} \quad \text{horizontally towards West.}$$

Inner Circle

$r = 5 \text{ cm} = 0.05 \text{ m}, \quad n = 50, \quad i = 2 \text{ A}$

$$\vec{B} = \frac{n\mu_0 i}{2r} = \frac{4\pi \times 10^{-7} \times 2 \times 50}{2 \times 0.05} = 4\pi \times 10^{-4} \quad \text{downwards}$$

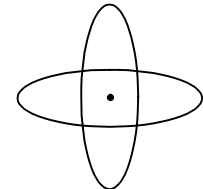

$$\text{Net } B = \sqrt{(4\pi \times 10^{-4})^2 + (4\pi \times 10^{-4})^2} = \sqrt{32\pi^2 \times 10^{-8}} = 17.7 \times 10^{-4} \approx 18 \times 10^{-4} = 1.8 \times 10^{-3} = 1.8 \text{ mT}$$

38. $r = 20 \text{ cm}, \quad i = 10 \text{ A}, \quad V = 2 \times 10^6 \text{ m/s}, \quad \theta = 30^\circ$

$$F = e(\vec{V} \times \vec{B}) = eVB \sin \theta$$

$$= 1.6 \times 10^{-19} \times 2 \times 10^6 \times \frac{\mu_0 i}{2r} \sin 30^\circ$$

$$= \frac{1.6 \times 10^{-19} \times 2 \times 10^6 \times 4\pi \times 10^{-7} \times 10}{2 \times 2 \times 20 \times 10^{-2}} = 16\pi \times 10^{-19} \text{ N}$$

39. \vec{B} Large loop = $\frac{\mu_0 I}{2R}$

'i' due to larger loop on the smaller loop

= $i(A \times B) = i AB \sin 90^\circ = i \times \pi r^2 \times \frac{\mu_0 I}{2R}$

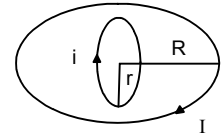

40. The force acting on the smaller loop

$F = i l B \sin \theta$

= $\frac{i 2\pi r \mu_0 I i}{2R \times 2} = \frac{\mu_0 i^2 \pi r}{2R}$

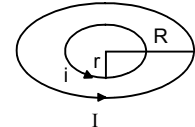

41. $i = 5$ Ampere, $r = 10 \text{ cm} = 0.1 \text{ m}$

As the semicircular wire forms half of a circular wire,

So, $\vec{B} = \frac{1}{2} \frac{\mu_0 i}{2r} = \frac{1}{2} \times \frac{4\pi \times 10^{-7} \times 5}{2 \times 0.1}$
 = $15.7 \times 10^{-6} \text{ T} \approx 16 \times 10^{-6} \text{ T} = 1.6 \times 10^{-5} \text{ T}$

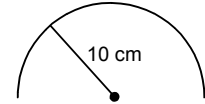

42. $B = \frac{\mu_0 i}{2R} \frac{\theta}{2\pi} = \frac{2\pi}{3 \times 2\pi} \times \frac{\mu_0 i}{2R}$

= $\frac{4\pi \times 10^{-7} \times 6}{6 \times 10^{10^{-2}}} = 4\pi \times 10^{-6}$
 = $4 \times 3.14 \times 10^{-6} = 12.56 \times 10^{-6} = 1.26 \times 10^{-5} \text{ T}$

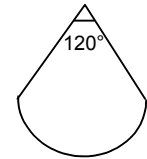

43. \vec{B} due to loop $\frac{\mu_0 i}{2r}$

Let the straight current carrying wire be kept at a distance R from centre. Given $I = 4i$

\vec{B} due to wire = $\frac{\mu_0 I}{2\pi R} = \frac{\mu_0 \times 4i}{2\pi R}$

Now, the \vec{B} due to both will balance each other

Hence $\frac{\mu_0 i}{2r} = \frac{\mu_0 4i}{2\pi R} \Rightarrow R = \frac{4r}{\pi}$

Hence the straight wire should be kept at a distance $4r/\pi$ from centre in such a way that the direction of current in it is opposite to that in the nearest part of circular wire. As a result the direction will \vec{B} will be oppose.

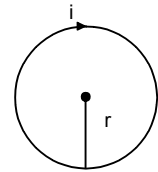

44. $n = 200$, $i = 2 \text{ A}$, $r = 10 \text{ cm} = 10 \times 10^{-2} \text{ m}$

(a) $B = \frac{n\mu_0 i}{2r} = \frac{200 \times 4\pi \times 10^{-7} \times 2}{2 \times 10 \times 10^{-2}} = 2 \times 4\pi \times 10^{-4}$
 = $2 \times 4 \times 3.14 \times 10^{-4} = 25.12 \times 10^{-4} \text{ T} = 2.512 \text{ mT}$

(b) $B = \frac{n\mu_0 i a^2}{2(a^2 + d^2)^{3/2}} \Rightarrow \frac{n\mu_0 i}{4a} = \frac{n\mu_0 i a^2}{2(a^2 + d^2)^{3/2}}$

$\Rightarrow \frac{1}{2a} = \frac{a^2}{2(a^2 + d^2)^{3/2}} \Rightarrow (a^2 + d^2)^{3/2} = 2a^3 \Rightarrow a^2 + d^2 = (2a^3)^{2/3}$

$\Rightarrow a^2 + d^2 = (2^{2/3} a^2) \Rightarrow (10^{-1})^2 + d^2 = 2^{2/3} (10^{-1})^2$

$\Rightarrow 10^{-2} + d^2 = 2^{2/3} 10^{-2} \Rightarrow (10^{-2})(2^{2/3} - 1) = d^2 \Rightarrow (10^{-2})(4^{1/3} - 1) = d^2$

$\Rightarrow 10^{-2}(1.5874 - 1) = d^2 \Rightarrow d^2 = 10^{-2} \times 0.5874$

$\Rightarrow d = \sqrt{10^{-2} \times 0.5874} = 10^{-1} \times 0.766 \text{ m} = 7.66 \times 10^{-2} = 7.66 \text{ cm}$.

45. At O P the \vec{B} must be directed downwards

We Know B at the axial line at O & P

= $\frac{\mu_0 i a^2}{2(a^2 + d^2)^{3/2}}$ $a = 4 \text{ cm} = 0.04 \text{ m}$

= $\frac{4\pi \times 10^{-7} \times 5 \times 0.0016}{2(0.0025)^{3/2}}$ $d = 3 \text{ cm} = 0.03 \text{ m}$

= $40 \times 10^{-6} = 4 \times 10^{-5} \text{ T}$ downwards in both the cases

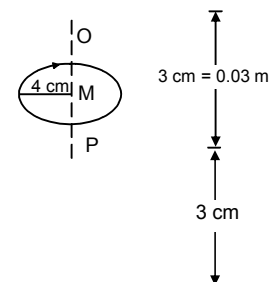

46. $q = 3.14 \times 10^{-6} \text{ C}$, $r = 20 \text{ cm} = 0.2 \text{ m}$,
 $w = 60 \text{ rad/sec.}$, $i = \frac{q}{t} = \frac{3.14 \times 10^{-6} \times 60}{2\pi \times 0.2} = 1.5 \times 10^{-5}$

$$\frac{\text{Electric field}}{\text{Magnetic field}} = \frac{\frac{xQ}{4\pi\epsilon_0(x^2+a^2)^{3/2}}}{\frac{\mu_0 ia^2}{2(a^2+x^2)^{3/2}}} = \frac{xQ}{4\pi\epsilon_0(x^2+a^2)^{3/2}} \times \frac{2(x^2+a^2)^{3/2}}{\mu_0 ia^2}$$

$$= \frac{9 \times 10^9 \times 0.05 \times 3.14 \times 10^{-6} \times 2}{4\pi \times 10^{-7} \times 15 \times 10^{-5} \times (0.2)^2}$$

$$= \frac{9 \times 5 \times 2 \times 10^3}{4 \times 13 \times 4 \times 10^{-12}} = \frac{3}{8}$$

47. (a) For inside the tube $\vec{B} = 0$

As, \vec{B} inside the conducting tube = 0

(b) For \vec{B} outside the tube

$$d = \frac{3r}{2}$$

$$\vec{B} = \frac{\mu_0 i}{2\pi d} = \frac{\mu_0 i \times 2}{2\pi 3r} = \frac{\mu_0 i}{2\pi r}$$

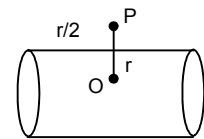

48. (a) At a point just inside the tube the current enclosed in the closed surface = 0.

Thus $B = \frac{\mu_0 0}{A} = 0$

(b) Taking a cylindrical surface just outside the tube, from ampere's law.

$$\mu_0 i = B \times 2\pi b \Rightarrow B = \frac{\mu_0 i}{2\pi b}$$

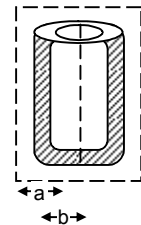

49. i is uniformly distributed throughout.

So, ' i ' for the part of radius $a = \frac{i}{\pi b^2} \times \pi a^2 = \frac{ia^2}{b^2} = I$

Now according to Ampere's circuital law

$$\oint \vec{B} \times d\vec{l} = B \times 2 \times \pi \times a = \mu_0 I$$

$$\Rightarrow B = \mu_0 \frac{ia^2}{b^2} \times \frac{1}{2\pi a} = \frac{\mu_0 ia}{2\pi b^2}$$

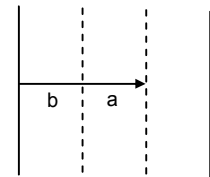

50. (a) $r = 10 \text{ cm} = 10 \times 10^{-2} \text{ m}$
 $x = 2 \times 10^{-2} \text{ m}$, $i = 5 \text{ A}$
 i in the region of radius 2 cm

$$\frac{5}{\pi(10 \times 10^{-2})^2} \times \pi(2 \times 10^{-2})^2 = 0.2 \text{ A}$$

$$B \times \pi (2 \times 10^{-2})^2 = \mu_0(0.2)$$

$$\Rightarrow B = \frac{4\pi \times 10^{-7} \times 0.2}{\pi \times 4 \times 10^{-4}} = \frac{0.2 \times 10^{-7}}{10^{-4}} = 2 \times 10^{-4}$$

(b) 10 cm radius

$$B \times \pi (10 \times 10^{-2})^2 = \mu_0 \times 5$$

$$\Rightarrow B = \frac{4\pi \times 10^{-7} \times 5}{\pi \times 10^{-2}} = 20 \times 10^{-5}$$

(c) $x = 20 \text{ cm}$

$$B \times \pi \times (20 \times 10^{-2})^2 = \mu_0 \times 5$$

$$\Rightarrow B = \frac{\mu_0 \times 5}{\pi \times (20 \times 10^{-2})^2} = \frac{4\pi \times 10^{-7} \times 5}{\pi \times 400 \times 10^{-4}} = 5 \times 10^{-5}$$

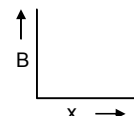

Magnetic Field due to Current

51. We know, $\int \mathbf{B} \times d\mathbf{l} = \mu_0 i$. Theoretically $B = 0$ at A

If, a current is passed through the loop PQRS, then

$$B = \frac{\mu_0 i}{2(\ell + b)}$$

Now, As the \vec{B} at A is zero. So there'll be no interaction

However practically this is not true. As a current carrying loop, irrespective of its near about position is always affected by an existing magnetic field.

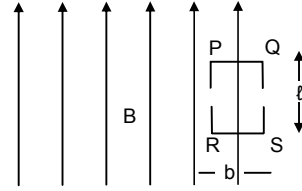

52. (a) At point P, $i = 0$, Thus $B = 0$

(b) At point R, $i = 0$, $B = 0$

(c) At point θ ,

Applying ampere's rule to the above rectangle

$$B \times 2l = \mu_0 K_0 \int_0^l dl$$

$$\Rightarrow B \times 2l = \mu_0 kl \Rightarrow B = \frac{\mu_0 k}{2}$$

$$B \times 2l = \mu_0 K_0 \int_0^l dl$$

$$\Rightarrow B \times 2l = \mu_0 kl \Rightarrow B = \frac{\mu_0 k}{2}$$

Since the \vec{B} due to the 2 stripes are along the same direction, thus.

$$B_{net} = \frac{\mu_0 k}{2} + \frac{\mu_0 k}{2} = \mu_0 k$$

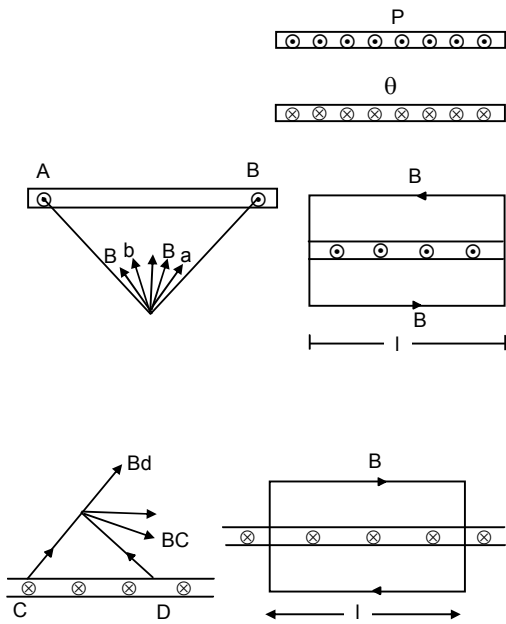

53. Charge = q , mass = m

We know radius described by a charged particle in a magnetic field B

$$r = \frac{mv}{qB}$$

But $B = \mu_0 K$ [according to Ampere's circuital law, where K is a constant]

$$r = \frac{mv}{q\mu_0 k} \Rightarrow v = \frac{rq\mu_0 k}{m}$$

54. $i = 25$ A, $B = 3.14 \times 10^{-2}$ T, $n = ?$

$$B = \mu_0 ni$$

$$\Rightarrow 3.14 \times 10^{-2} = 4 \times \pi \times 10^{-7} n \times 25$$

$$\Rightarrow n = \frac{10^{-2}}{20 \times 10^{-7}} = \frac{1}{2} \times 10^4 = 0.5 \times 10^4 = 5000 \text{ turns/m}$$

55. $r = 0.5$ mm, $i = 5$ A, $B = \mu_0 ni$ (for a solenoid)

Width of each turn = 1 mm = 10^{-3} m

$$\text{No. of turns 'n'} = \frac{1}{10^{-3}} = 10^3$$

$$\text{So, } B = 4\pi \times 10^{-7} \times 10^3 \times 5 = 2\pi \times 10^{-3} \text{ T}$$



56. $\frac{R}{l} = 0.01 \Omega$ in 1 m, $r = 1.0$ cm Total turns = 400, $\ell = 20$ cm,

$$B = 1 \times 10^{-2} \text{ T, } n = \frac{400}{20 \times 10^{-2}} \text{ turns/m}$$

$$i = \frac{E}{R_0} = \frac{E}{R_0 / l \times (2\pi r \times 400)} = \frac{E}{0.01 \times 2 \times \pi \times 0.01 \times 400}$$

$$B = \mu_0 ni$$

$$\Rightarrow 10^2 = 4\pi \times 10^{-7} \times \frac{400}{20 \times 10^{-2}} \times \frac{E}{400 \times 2\pi \times 0.01 \times 10^{-2}}$$

$$\Rightarrow E = \frac{10^{-2} \times 20 \times 10^{-2} \times 400 \times 2\pi \times 10^{-2} \times 0.01}{4\pi \times 10^{-7} \times 400} = 1 \text{ V}$$

57. Current at '0' due to the circular loop = $dB = \frac{\mu_0}{4\pi} \times \frac{a^2 \text{ind}x}{\left[a^2 + \left(\frac{\ell}{2} - x \right)^2 \right]^{3/2}}$

\therefore for the whole solenoid $B = \int_0^{\ell} dB$

$$= \int_0^{\ell} \frac{\mu_0 a^2 \text{nid}x}{4\pi \left[a^2 + \left(\frac{\ell}{2} - x \right)^2 \right]^{3/2}}$$

$$= \frac{\mu_0 \text{ni}}{4\pi} \int_0^{\ell} \frac{a^2 dx}{a^3 \left[1 + \left(\frac{\ell - 2x}{2a} \right)^2 \right]^{3/2}} = \frac{\mu_0 \text{ni}}{4\pi a} \int_0^{\ell} \frac{dx}{\left[1 + \left(\frac{\ell - 2x}{2a} \right)^2 \right]^{3/2}} = 1 + \left(\frac{\ell - 2x}{2a} \right)^2$$

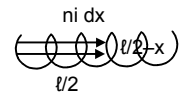

58. $i = 2 \text{ a}$, $f = 10^8 \text{ rev/sec}$, $n = ?$, $m_e = 9.1 \times 10^{-31} \text{ kg}$,
 $q_e = 1.6 \times 10^{-19} \text{ c}$, $B = \mu_0 \text{ni} \Rightarrow n = \frac{B}{\mu_0 i}$

$$f = \frac{qB}{2\pi m_e} \Rightarrow B = \frac{f 2\pi m_e}{q_e} \Rightarrow n = \frac{B}{\mu_0 i} = \frac{f 2\pi m_e}{q_e \mu_0 i} = \frac{10^8 \times 9.1 \times 10^{-31}}{1.6 \times 10^{-19} \times 2 \times 10^{-7} \times 2A} = 1421 \text{ turns/m}$$

59. No. of turns per unit length = n , radius of circle = $r/2$, current in the solenoid = i ,
 Charge of Particle = q , mass of particle = m $\therefore B = \mu_0 \text{ni}$

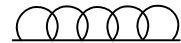

Again $\frac{mV^2}{r} = qVB \Rightarrow V = \frac{qBr}{m} = \frac{q\mu_0 \text{ni}r}{2m} = \frac{\mu_0 \text{ni}qr}{2m}$

60. No. of turns per unit length = ℓ
 (a) As the net magnetic field = zero

$\therefore \vec{B}_{\text{plate}} = \vec{B}_{\text{Solenoid}}$

$\vec{B}_{\text{plate}} \times 2\ell = \mu_0 k \ell = \mu_0 k \ell$

$\vec{B}_{\text{plate}} = \frac{\mu_0 k}{2} \dots(1)$

$\vec{B}_{\text{Solenoid}} = \mu_0 \text{ni} \dots(2)$

Equating both $i = \frac{\mu_0 k}{2}$

(b) $B_a \times \ell = \mu k \ell \Rightarrow B_a = \mu_0 k$ $B_C = \mu_0 k$

$B = \sqrt{B_a^2 + B_C^2} = \sqrt{2(\mu_0 k)^2} = \sqrt{2} \mu_0 k$

$2 \mu_0 k = \mu_0 \text{ni}$ $i = \frac{\sqrt{2}k}{n}$

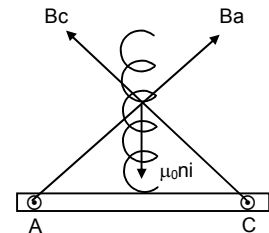

61. $C = 100 \mu\text{f}$, $Q = CV = 2 \times 10^{-3} \text{ C}$, $t = 2 \text{ sec}$,
 $V = 20 \text{ V}$, $V' = 18 \text{ V}$, $Q' = CV = 1.8 \times 10^{-3} \text{ C}$,

$\therefore i = \frac{Q - Q'}{t} = \frac{2 \times 10^{-4}}{2} = 10^{-4} \text{ A}$ $n = 4000 \text{ turns/m}$.

$\therefore B = \mu_0 \text{ni} = 4\pi \times 10^{-7} \times 4000 \times 10^{-4} = 16 \pi \times 10^{-7} \text{ T}$



CHAPTER – 36 PERMANENT MAGNETS

1. $m = 10 \text{ A-m}$, $d = 5 \text{ cm} = 0.05 \text{ m}$

$$B = \frac{\mu_0 m}{4\pi r^2} = \frac{10^{-7} \times 10}{(5 \times 10^{-2})^2} = \frac{10^{-2}}{25} = 4 \times 10^{-4} \text{ Tesla}$$

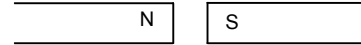

2. $m_1 = m_2 = 10 \text{ A-m}$
 $r = 2 \text{ cm} = 0.02 \text{ m}$
 we know

$$\text{Force exerted by tow magnetic poles on each other} = \frac{\mu_0 m_1 m_2}{4\pi r^2} = \frac{4\pi \times 10^{-7} \times 10^2}{4\pi \times 4 \times 10^{-4}} = 2.5 \times 10^{-2} \text{ N}$$

3. $B = -\frac{dv}{dl} \Rightarrow dv = -B dl = -0.2 \times 10^{-3} \times 0.5 = -0.1 \times 10^{-3} \text{ T-m}$

Since the sign is -ve therefore potential decreases.

4. Here $dx = 10 \sin 30^\circ \text{ cm} = 5 \text{ cm}$

$$\frac{dV}{dx} = B = \frac{0.1 \times 10^{-4} \text{ T-m}}{5 \times 10^{-2} \text{ m}}$$

Since B is perpendicular to equipotential surface.

Here it is at angle 120° with (+ve) x-axis and $B = 2 \times 10^{-4} \text{ T}$

5. $B = 2 \times 10^{-4} \text{ T}$

$d = 10 \text{ cm} = 0.1 \text{ m}$

(a) if the point at end-on position.

$$B = \frac{\mu_0 2M}{4\pi d^3} \Rightarrow 2 \times 10^{-4} = \frac{10^{-7} \times 2M}{(10^{-1})^3}$$

$$\Rightarrow \frac{2 \times 10^{-4} \times 10^{-3}}{10^{-7} \times 2} = M \Rightarrow M = 1 \text{ Am}^2$$

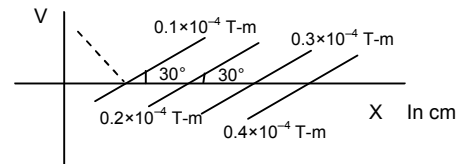

(b) If the point is at broad-on position

$$\frac{\mu_0 M}{4\pi d^3} \Rightarrow 2 \times 10^{-4} = \frac{10^{-7} \times M}{(10^{-1})^3} \Rightarrow M = 2 \text{ Am}^2$$

6. Given :

$$\theta = \tan^{-1} \sqrt{2} \Rightarrow \tan \theta = \sqrt{2} \Rightarrow 2 = \tan^2 \theta$$

$$\Rightarrow \tan \theta = 2 \cot \theta \Rightarrow \frac{\tan \theta}{2} = \cot \theta$$

$$\text{We know } \frac{\tan \theta}{2} = \tan \alpha$$

Comparing we get, $\tan \alpha = \cot \theta$

$$\text{or, } \tan \alpha = \tan(90 - \theta) \quad \text{or } \alpha = 90 - \theta \quad \text{or } \theta + \alpha = 90$$

Hence magnetic field due to the dipole is \perp to the magnetic axis.

7. Magnetic field at the broad side on position :

$$B = \frac{\mu_0 M}{4\pi (d^2 + \ell^2)^{3/2}} \quad 2\ell = 8 \text{ cm} \quad d = 3 \text{ cm}$$

$$\Rightarrow 4 \times 10^{-6} = \frac{10^{-7} \times m \times 8 \times 10^{-2}}{(9 \times 10^{-4} + 16 \times 10^{-4})^{3/2}} \Rightarrow 4 \times 10^{-6} = \frac{10^{-9} \times m \times 8}{(10^{-4})^{3/2} + (25)^{3/2}}$$

$$\Rightarrow m = \frac{4 \times 10^{-6} \times 125 \times 10^{-8}}{8 \times 10^{-9}} = 62.5 \times 10^{-5} \text{ A-m}$$

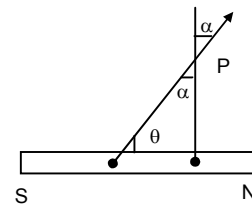

8. We know for a magnetic dipole with its north pointing the north, the neutral point in the broadside on position.

$$\text{Again } \vec{B} \text{ in this case} = \frac{\mu_0 M}{4\pi d^3}$$

$$\therefore \frac{\mu_0 M}{4\pi d^3} = \vec{B}_H \text{ due to earth}$$

$$\Rightarrow \frac{10^{-7} \times 1.44}{d^3} = 18 \mu\text{T}$$

$$\Rightarrow \frac{10^{-7} \times 1.44}{d^3} = 18 \times 10^{-6}$$

$$\Rightarrow d^3 = 8 \times 10^{-3}$$

$$\Rightarrow d = 2 \times 10^{-1} \text{ m} = 20 \text{ cm}$$

In the plane bisecting the dipole.

9. When the magnet is such that its North faces the geographic south of earth. The neutral point lies along the axial line of the magnet.

$$\frac{\mu_0 2M}{4\pi d^3} = 18 \times 10^{-6} \Rightarrow \frac{10^{-7} \times 2 \times 0.72}{d^3} = 18 \times 10^{-6} \Rightarrow d^3 = \frac{2 \times 0.7 \times 10^{-7}}{18 \times 10^{-6}}$$

$$\Rightarrow d = \left(\frac{8 \times 10^{-9}}{10^{-6}} \right)^{1/3} = 2 \times 10^{-1} \text{ m} = 20 \text{ cm}$$

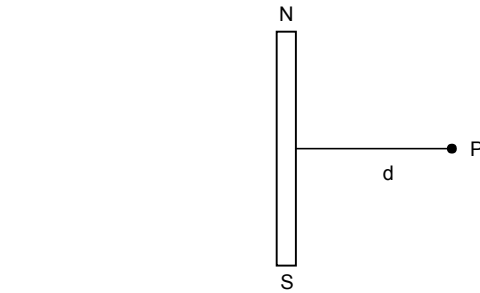

10. Magnetic moment = $0.72\sqrt{2} \text{ A}\cdot\text{m}^2 = M$

$$B = \frac{\mu_0 M}{4\pi d^3} \quad B_H = 18 \mu\text{T}$$

$$\Rightarrow \frac{4\pi \times 10^{-7} \times 0.72\sqrt{2}}{4\pi \times d^3} = 18 \times 10^{-6}$$

$$\Rightarrow d^3 = \frac{0.72 \times 1.414 \times 10^{-7}}{18 \times 10^{-6}} = 0.005656$$

$$\Rightarrow d \approx 0.2 \text{ m} = 20 \text{ cm}$$

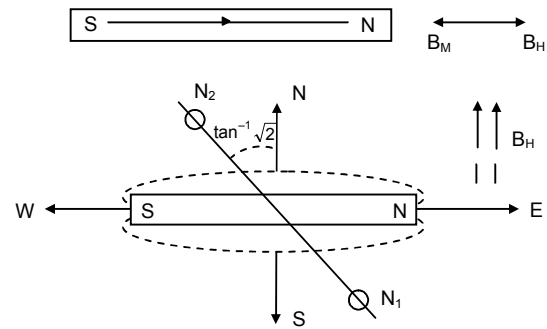

11. The geomagnetic pole is at the end on position of the earth.

$$B = \frac{\mu_0 2M}{4\pi d^3} = \frac{10^{-7} \times 2 \times 8 \times 10^{22}}{(6400 \times 10^3)^3} \approx 60 \times 10^{-6} \text{ T} = 60 \mu\text{T}$$

12. $\vec{B} = 3.4 \times 10^{-5} \text{ T}$

$$\text{Given } \frac{\mu_0 M}{4\pi R^3} = 3.4 \times 10^{-5}$$

$$\Rightarrow M = \frac{3.4 \times 10^{-5} \times R^3 \times 4\pi}{4\pi \times 10^{-7}} = 3.4 \times 10^2 R^3$$

$$\vec{B} \text{ at Poles} = \frac{\mu_0 2M}{4\pi R^3} = 6.8 \times 10^{-5} \text{ T}$$

13. $\delta(\text{dip}) = 60^\circ$

$$B_H = B \cos 60^\circ$$

$$\Rightarrow B = 52 \times 10^{-6} = 52 \mu\text{T}$$

$$B_V = B \sin \delta = 52 \times 10^{-6} \frac{\sqrt{3}}{2} = 44.98 \mu\text{T} \approx 45 \mu\text{T}$$

14. If δ_1 and δ_2 be the apparent dips shown by the dip circle in the $2\perp r$ positions, the true dip δ is given by

$$\text{Cot}^2 \delta = \text{Cot}^2 \delta_1 + \text{Cot}^2 \delta_2$$

$$\Rightarrow \text{Cot}^2 \delta = \text{Cot}^2 45^\circ + \text{Cot}^2 53^\circ$$

$$\Rightarrow \text{Cot}^2 \delta = 1.56 \Rightarrow \delta = 38.6 \approx 39^\circ$$

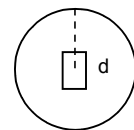

15. We know $B_H = \frac{\mu_0 i n}{2r}$
 Give : $B_H = 3.6 \times 10^{-5} \text{ T}$ $\theta = 45^\circ$
 $i = 10 \text{ mA} = 10^{-2} \text{ A}$ $\tan \theta = 1$
 $n = ?$ $r = 10 \text{ cm} = 0.1 \text{ m}$

$$n = \frac{B_H \tan \theta \times 2r}{\mu_0 i} = \frac{3.6 \times 10^{-5} \times 2 \times 1 \times 10^{-1}}{4\pi \times 10^{-7} \times 10^{-2}} = 0.5732 \times 10^3 \approx 573 \text{ turns}$$

16. $n = 50$ $A = 2 \text{ cm} \times 2 \text{ cm} = 2 \times 2 \times 10^{-4} \text{ m}^2$
 $i = 20 \times 10^{-3} \text{ A}$ $B = 0.5 \text{ T}$
 $\tau = ni(\vec{A} \times \vec{B}) = niAB \sin 90^\circ = 50 \times 20 \times 10^{-3} \times 4 \times 10^{-4} \times 0.5 = 2 \times 10^{-4} \text{ N-M}$

17. Given $\theta = 37^\circ$ $d = 10 \text{ cm} = 0.1 \text{ m}$
 We know

$$\frac{M}{B_H} = \frac{4\pi (d^2 - \ell^2)^2}{\mu_0 2d} \tan \theta = \frac{4\pi}{\mu_0} \times \frac{d^4}{2d} \tan \theta \text{ [As the magnet is short]}$$

$$= \frac{4\pi}{4\pi \times 10^{-7}} \times \frac{(0.1)^3}{2} \times \tan 37^\circ = 0.5 \times 0.75 \times 1 \times 10^{-3} \times 10^7 = 0.375 \times 10^4 = 3.75 \times 10^3 \text{ A-m}^2 \text{ T}^{-1}$$

18. $\frac{M}{B_H}$ (found in the previous problem) = $3.75 \times 10^3 \text{ A-m}^2 \text{ T}^{-1}$

$\theta = 37^\circ$, $d = ?$

$$\frac{M}{B_H} = \frac{4\pi}{\mu_0} (d^2 + \ell^2)^{3/2} \tan \theta$$

$\ell \ll d$ neglecting ℓ w.r.t. d

$$\Rightarrow \frac{M}{B_H} = \frac{4\pi}{\mu_0} d^3 \tan \theta \Rightarrow 3.75 \times 10^3 = \frac{1}{10^{-7}} \times d^3 \times 0.75$$

$$\Rightarrow d^3 = \frac{3.75 \times 10^3 \times 10^{-7}}{0.75} = 5 \times 10^{-4}$$

$$\Rightarrow d = 0.079 \text{ m} = 7.9 \text{ cm}$$

19. Given $\frac{M}{B_H} = 40 \text{ A-m}^2/\text{T}$

Since the magnet is short 'l' can be neglected

So,
$$\frac{M}{B_H} = \frac{4\pi}{\mu_0} \times \frac{d^3}{2} = 40$$

$$\Rightarrow d^3 = \frac{40 \times 4\pi \times 10^{-7} \times 2}{4\pi} = 8 \times 10^{-6}$$

$$\Rightarrow d = 2 \times 10^{-2} \text{ m} = 2 \text{ cm}$$

with the north pole pointing towards south.

20. According to oscillation magnetometer,

$$T = 2\pi \sqrt{\frac{I}{MB_H}}$$

$$\Rightarrow \frac{\pi}{10} = 2\pi \sqrt{\frac{1.2 \times 10^{-4}}{M \times 30 \times 10^{-6}}}$$

$$\Rightarrow \left(\frac{1}{20}\right)^2 = \frac{1.2 \times 10^{-4}}{M \times 30 \times 10^{-6}}$$

$$\Rightarrow M = \frac{1.2 \times 10^{-4} \times 400}{30 \times 10^{-6}} = 16 \times 10^2 \text{ A-m}^2 = 1600 \text{ A-m}^2$$

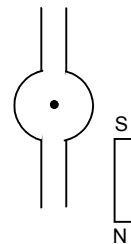

21. We know : $\nu = \frac{1}{2\pi} \sqrt{\frac{mB_H}{I}}$

For like poles tied together

$M = M_1 - M_2$

For unlike poles $M' = M_1 + M_2$

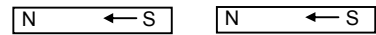

$$\frac{\nu_1}{\nu_2} = \sqrt{\frac{M_1 - M_2}{M_1 + M_2}} \Rightarrow \left(\frac{10}{2}\right)^2 = \frac{M_1 - M_2}{M_1 + M_2} \Rightarrow 25 = \frac{M_1 - M_2}{M_1 + M_2}$$

$$\Rightarrow \frac{26}{24} = \frac{2M_1}{2M_2} \Rightarrow \frac{M_1}{M_2} = \frac{13}{12}$$

22. $B_H = 24 \times 10^{-6} \text{ T}$ $T_1 = 0.1 \text{ '}$

$$B = B_H - B_{\text{wire}} = 24 \times 10^{-6} - \frac{\mu_0 i}{2\pi r} = 24 \times 10^{-6} - \frac{2 \times 10^{-7} \times 18}{0.2} = (24 - 10) \times 10^{-6} = 14 \times 10^{-6}$$

$$T = 2\pi \sqrt{\frac{I}{MB_H}} \quad \frac{T_1}{T_2} = \sqrt{\frac{B}{B_H}}$$

$$\Rightarrow \frac{0.1}{T_2} = \sqrt{\frac{14 \times 10^{-6}}{24 \times 10^{-6}}} \Rightarrow \left(\frac{0.1}{T_2}\right)^2 = \frac{14}{24} \Rightarrow T_2^2 = \frac{0.01 \times 14}{24} \Rightarrow T_2 = 0.076$$

23. $T = 2\pi \sqrt{\frac{I}{MB_H}}$ Here $I' = 2I$

$T_1 = \frac{1}{40} \text{ min}$ $T_2 = ?$

$$\frac{T_1}{T_2} = \sqrt{\frac{I}{I'}}$$

$$\Rightarrow \frac{1}{40T_2} = \sqrt{\frac{1}{2}} \Rightarrow \frac{1}{1600T_2^2} = \frac{1}{2} \Rightarrow T_2^2 = \frac{1}{800} \Rightarrow T_2 = 0.03536 \text{ min}$$

For 1 oscillation Time taken = 0.03536 min.

For 40 Oscillation Time = $4 \times 0.03536 = 1.414 = \sqrt{2} \text{ min}$

24. $\gamma_1 = 40 \text{ oscillations/minute}$

$B_H = 25 \mu\text{T}$

m of second magnet = 1.6 A-m²

d = 20 cm = 0.2 m

(a) For north facing north

$$\gamma_1 = \frac{1}{2\pi} \sqrt{\frac{MB_H}{I}} \quad \gamma_2 = \frac{1}{2\pi} \sqrt{\frac{M(B_H - B)}{I}}$$

$$B = \frac{\mu_0 m}{4\pi d^3} = \frac{10^{-7} \times 1.6}{8 \times 10^{-3}} = 20 \mu\text{T}$$

$$\frac{\gamma_1}{\gamma_2} = \sqrt{\frac{B}{B_H - B}} \Rightarrow \frac{40}{\gamma_2} = \sqrt{\frac{25}{5}} \Rightarrow \gamma_2 = \frac{40}{\sqrt{5}} = 17.88 \approx 18 \text{ osci/min}$$

(b) For north pole facing south

$$\gamma_1 = \frac{1}{2\pi} \sqrt{\frac{MB_H}{I}} \quad \gamma_2 = \frac{1}{2\pi} \sqrt{\frac{M(B_H + B)}{I}}$$

$$\frac{\gamma_1}{\gamma_2} = \sqrt{\frac{B}{B_H + B}} \Rightarrow \frac{40}{\gamma_2} = \sqrt{\frac{25}{45}} \Rightarrow \gamma_2 = \frac{40}{\sqrt{\left(\frac{25}{45}\right)}} = 53.66 \approx 54 \text{ osci/min}$$



CHAPTER – 37
MAGNETIC PROPERTIES OF MATTER

1. $B = \mu_0 ni$, $H = \frac{B}{\mu_0}$

$\Rightarrow H = ni$

$\Rightarrow 1500 \text{ A/m} = n \times 2$

$\Rightarrow n = 750 \text{ turns/meter}$

$\Rightarrow n = 7.5 \text{ turns/cm}$

2. (a) $H = 1500 \text{ A/m}$

As the solenoid and the rod are long and we are interested in the magnetic intensity at the centre, the end effects may be neglected. There is no effect of the rod on the magnetic intensity at the centre.

(b) $I = 0.12 \text{ A/m}$

We know $\vec{I} = X\vec{H}$ $X = \text{Susceptibility}$

$\Rightarrow X = \frac{I}{H} = \frac{0.12}{1500} = 0.00008 = 8 \times 10^{-5}$

(c) The material is paramagnetic

3. $B_1 = 2.5 \times 10^{-3}$, $B_2 = 2.5$
 $A = 4 \times 10^{-4} \text{ m}^2$, $n = 50 \text{ turns/cm} = 5000 \text{ turns/m}$

(a) $B = \mu_0 ni$,

$\Rightarrow 2.5 \times 10^{-3} = 4\pi \times 10^{-7} \times 5000 \times i$

$\Rightarrow i = \frac{2.5 \times 10^{-3}}{4\pi \times 10^{-7} \times 5000} = 0.398 \text{ A} \approx 0.4 \text{ A}$

(b) $I = \frac{B_2}{\mu_0} - H = \frac{2.5}{4\pi \times 10^{-7}} - (B_2 - B_1) = \frac{2.5}{4\pi \times 10^{-7}} - 2.497 = 1.99 \times 10^6 \approx 2 \times 10^6$

(c) $I = \frac{M}{V} \Rightarrow I = \frac{m\ell}{A\ell} = \frac{m}{A}$

$\Rightarrow m = IA = 2 \times 10^6 \times 4 \times 10^{-4} = 800 \text{ A-m}$

4. (a) Given $d = 15 \text{ cm} = 0.15 \text{ m}$

$\ell = 1 \text{ cm} = 0.01 \text{ m}$

$A = 1.0 \text{ cm}^2 = 1 \times 10^{-4} \text{ m}^2$

$B = 1.5 \times 10^{-4} \text{ T}$

$M = ?$

We Know $\vec{B} = \frac{\mu_0}{4\pi} \times \frac{2Md}{(d^2 - \ell^2)^2}$

$\Rightarrow 1.5 \times 10^{-4} = \frac{10^{-7} \times 2 \times M \times 0.15}{(0.0225 - 0.0001)^2} = \frac{3 \times 10^{-8} M}{5.01 \times 10^{-4}}$

$\Rightarrow M = \frac{1.5 \times 10^{-4} \times 5.01 \times 10^{-4}}{3 \times 10^{-8}} = 2.5 \text{ A}$

(b) Magnetisation $I = \frac{M}{V} = \frac{2.5}{10^{-4} \times 10^{-2}} = 2.5 \times 10^6 \text{ A/m}$

(c) $H = \frac{m}{4\pi d^2} = \frac{M}{4\pi Id^2} = \frac{2.5}{4 \times 3.14 \times 0.01 \times (0.15)^2}$

net $H = H_N + H = 2 \times 884.6 = 8.846 \times 10^2$

$\vec{B} = \mu_0 (-H + I) = 4\pi \times 10^{-7} (2.5 \times 10^6 - 2 \times 884.6) \approx 3.14 \text{ T}$

5. Permeability (μ) = $\mu_0(1 + x)$

Given susceptibility = 5500

$$\mu = 4 \times 10^{-7} (1 + 5500)$$

$$= 4 \times 3.14 \times 10^{-7} \times 5501 = 6909.56 \times 10^{-7} \approx 6.9 \times 10^{-3}$$

6. $B = 1.6 \text{ T}$, $H = 1000 \text{ A/m}$

μ = Permeability of material

$$\mu = \frac{B}{H} = \frac{1.6}{1000} = 1.6 \times 10^{-3}$$

$$\mu_r = \frac{\mu}{\mu_0} = \frac{1.6 \times 10^{-3}}{4\pi \times 10^{-7}} = 0.127 \times 10^4 \approx 1.3 \times 10^3$$

$$\mu = \mu_0 (1 + x)$$

$$\Rightarrow x = \frac{\mu}{\mu_0} - 1$$

$$= \mu_r - 1 = 1.3 \times 10^3 - 1 = 1300 - 1 = 1299 \approx 1.3 \times 10^3$$

7. $x = \frac{C}{T} \Rightarrow \frac{x_1}{x_2} = \frac{T_2}{T_1}$

$$\Rightarrow \frac{1.2 \times 10^{-5}}{1.8 \times 10^{-5}} = \frac{T_2}{300}$$

$$\Rightarrow T_2 = \frac{12}{18} \times 300 = 200 \text{ K.}$$

8. $f = 8.52 \times 10^{28} \text{ atoms/m}^3$

For maximum 'I', Let us consider the no. of atoms present in 1 m^3 of volume.

Given: m per atom = $2 \times 9.27 \times 10^{-24} \text{ A-m}^2$

$$I = \frac{\text{net } m}{V} = 2 \times 9.27 \times 10^{-24} \times 8.52 \times 10^{28} \approx 1.58 \times 10^6 \text{ A/m}$$

$$B = \mu_0 (H + I) = \mu_0 I \quad [\because H = 0 \text{ in this case}]$$

$$= 4\pi \times 10^{-7} \times 1.58 \times 10^6 = 1.98 \times 10^{-1} \approx 2.0 \text{ T}$$

9. $B = \mu_0 ni$, $H = \frac{B}{\mu_0}$

Given $n = 40 \text{ turn/cm} = 4000 \text{ turns/m}$

$$\Rightarrow H = ni$$

$$H = 4 \times 10^4 \text{ A/m}$$

$$\Rightarrow i = \frac{H}{n} = \frac{4 \times 10^4}{4000} = 10 \text{ A.}$$

* * * * *

ELECTROMAGNETIC INDUCTION CHAPTER - 38

1. (a) $\int E \cdot dl = MLT^{-3}I^{-1} \times L = ML^2I^{-1}T^{-3}$
 (b) $\oint BI = LT^{-1} \times MI^{-1}T^{-2} \times L = ML^2I^{-1}T^{-3}$
 (c) $d\phi_s / dt = MI^{-1}T^{-2} \times L^2 = ML^2I^{-1}T^{-2}$

2. $\phi = at^2 + bt + c$

(a) $a = \left[\frac{\phi}{t^2} \right] = \left[\frac{\phi/t}{t} \right] = \frac{\text{Volt}}{\text{Sec}}$

$b = \left[\frac{\phi}{t} \right] = \text{Volt}$

$c = [\phi] = \text{Weber}$

(b) $E = \frac{d\phi}{dt} \quad [a = 0.2, b = 0.4, c = 0.6, t = 2s]$

$= 2at + b$

$= 2 \times 0.2 \times 2 + 0.4 = 1.2 \text{ volt}$

3. (a) $\phi_2 = B.A. = 0.01 \times 2 \times 10^{-3} = 2 \times 10^{-5}$
 $\phi_1 = 0$

$e = -\frac{d\phi}{dt} = \frac{-2 \times 10^{-5}}{10 \times 10^{-3}} = -2 \text{ mV}$

$\phi_3 = B.A. = 0.03 \times 2 \times 10^{-3} = 6 \times 10^{-5}$

$d\phi = 4 \times 10^{-5}$

$e = -\frac{d\phi}{dt} = -4 \text{ mV}$

$\phi_4 = B.A. = 0.01 \times 2 \times 10^{-3} = 2 \times 10^{-5}$

$d\phi = -4 \times 10^{-5}$

$e = -\frac{d\phi}{dt} = 4 \text{ mV}$

$\phi_5 = B.A. = 0$

$d\phi = -2 \times 10^{-5}$

$e = -\frac{d\phi}{dt} = 2 \text{ mV}$

(b) emf is not constant in case of $\rightarrow 10 - 20 \text{ ms}$ and $20 - 30 \text{ ms}$ as -4 mV and 4 mV .

4. $\phi_1 = BA = 0.5 \times \pi(5 \times 10^{-2})^2 = 5\pi \times 25 \times 10^{-5} = 125 \times 10^{-5}$
 $\phi_2 = 0$

$E = \frac{\phi_1 - \phi_2}{t} = \frac{125\pi \times 10^{-5}}{5 \times 10^{-1}} = 25\pi \times 10^{-4} = 7.8 \times 10^{-3}$

5. $A = 1 \text{ mm}^2$; $i = 10 \text{ A}$, $d = 20 \text{ cm}$; $dt = 0.1 \text{ s}$

$e = \frac{d\phi}{dt} = \frac{BA}{dt} = \frac{\mu_0 i}{2\pi d} \times \frac{A}{dt}$

$= \frac{4\pi \times 10^{-7} \times 10}{2\pi \times 2 \times 10^{-1}} \times \frac{10^{-6}}{1 \times 10^{-1}} = 1 \times 10^{-10} \text{ V}$

6. (a) During removal,

$\phi_1 = B.A. = 1 \times 50 \times 0.5 \times 0.5 = 12.5 \text{ Tesla-m}^2$

$\phi_2 = 0, \tau = 0.25$

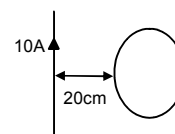
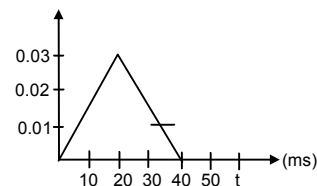

$$e = -\frac{d\phi}{dt} = \frac{\phi_2 - \phi_1}{dt} = \frac{12.5}{0.25} = \frac{125 \times 10^{-1}}{25 \times 10^{-2}} = 50V$$

(b) During its restoration

$$\phi_1 = 0 ; \phi_2 = 12.5 \text{ Tesla-m}^2 ; t = 0.25 \text{ s}$$

$$E = \frac{12.5 - 0}{0.25} = 50 \text{ V.}$$

(c) During the motion

$$\phi_1 = 0, \phi_2 = 0$$

$$E = \frac{d\phi}{dt} = 0$$

7. $R = 25 \Omega$

(a) $e = 50 \text{ V}, T = 0.25 \text{ s}$

$$i = e/R = 2A, H = i^2 RT \\ = 4 \times 25 \times 0.25 = 25 \text{ J}$$

(b) $e = 50 \text{ V}, T = 0.25 \text{ s}$

$$i = e/R = 2A, H = i^2 RT = 25 \text{ J}$$

(c) Since energy is a scalar quantity

$$\text{Net thermal energy developed} = 25 \text{ J} + 25 \text{ J} = 50 \text{ J.}$$

8. $A = 5 \text{ cm}^2 = 5 \times 10^{-4} \text{ m}^2$

$$B = B_0 \sin \omega t = 0.2 \sin(300 t)$$

$$\theta = 60^\circ$$

a) Max emf induced in the coil

$$E = -\frac{d\phi}{dt} = \frac{d}{dt}(BA \cos \theta) \\ = \frac{d}{dt}(B_0 \sin \omega t \times 5 \times 10^{-4} \times \frac{1}{2}) \\ = B_0 \times \frac{5}{2} \times 10^{-4} \frac{d}{dt}(\sin \omega t) = \frac{B_0 5}{2} \times 10^{-4} \cos \omega t \cdot \omega \\ = \frac{0.2 \times 5}{2} \times 300 \times 10^{-4} \times \cos \omega t = 15 \times 10^{-3} \cos \omega t$$

$$E_{\text{max}} = 15 \times 10^{-3} = 0.015 \text{ V}$$

b) Induced emf at $t = (\pi/900) \text{ s}$

$$E = 15 \times 10^{-3} \times \cos \omega t \\ = 15 \times 10^{-3} \times \cos (300 \times \pi/900) = 15 \times 10^{-3} \times \frac{1}{2} \\ = 0.015/2 = 0.0075 = 7.5 \times 10^{-3} \text{ V}$$

c) Induced emf at $t = \pi/600 \text{ s}$

$$E = 15 \times 10^{-3} \times \cos (300 \times \pi/600) \\ = 15 \times 10^{-3} \times 0 = 0 \text{ V.}$$

9. $\vec{B} = 0.10 \text{ T}$

$$A = 1 \text{ cm}^2 = 10^{-4} \text{ m}^2$$

$$T = 1 \text{ s}$$

$$\phi = B.A. = 10^{-1} \times 10^{-4} = 10^{-5}$$

$$e = \frac{d\phi}{dt} = \frac{10^{-5}}{1} = 10^{-5} = 10 \mu\text{V}$$

10. $E = 20 \text{ mV} = 20 \times 10^{-3} \text{ V}$

$$A = (2 \times 10^{-2})^2 = 4 \times 10^{-4}$$

$$Dt = 0.2 \text{ s}, \theta = 180^\circ$$

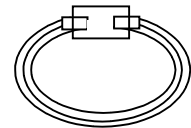

$$\phi_1 = BA, \phi_2 = -BA$$

$$d\phi = 2BA$$

$$E = \frac{d\phi}{dt} = \frac{2BA}{dt}$$

$$\Rightarrow 20 \times 10^{-3} = \frac{2 \times B \times 2 \times 10^{-4}}{2 \times 10^{-1}}$$

$$\Rightarrow 20 \times 10^{-3} = 4 \times B \times 10^{-3}$$

$$\Rightarrow B = \frac{20 \times 10^{-3}}{4 \times 10^{-3}} = 5T$$

11. Area = A, Resistance = R, B = Magnetic field

$$\phi = BA = Ba \cos 0^\circ = BA$$

$$e = \frac{d\phi}{dt} = \frac{BA}{1}; i = \frac{e}{R} = \frac{BA}{R}$$

$$\phi = iT = BA/R$$

12. $r = 2 \text{ cm} = 2 \times 10^{-2} \text{ m}$

$$n = 100 \text{ turns / cm} = 10000 \text{ turns/m}$$

$$i = 5 \text{ A}$$

$$B = \mu_0 ni$$

$$= 4\pi \times 10^{-7} \times 10000 \times 5 = 20\pi \times 10^{-3} = 62.8 \times 10^{-3} \text{ T}$$

$$n_2 = 100 \text{ turns}$$

$$R = 20 \Omega$$

$$r = 1 \text{ cm} = 10^{-2} \text{ m}$$

$$\text{Flux linking per turn of the second coil} = B\pi r^2 = B\pi \times 10^{-4}$$

$$\phi_1 = \text{Total flux linking} = Bn_2 \pi r^2 = 100 \times \pi \times 10^{-4} \times 20\pi \times 10^{-3}$$

When current is reversed.

$$\phi_2 = -\phi_1$$

$$d\phi = \phi_2 - \phi_1 = 2 \times 100 \times \pi \times 10^{-4} \times 20\pi \times 10^{-3}$$

$$E = -\frac{d\phi}{dt} = \frac{4\pi^2 \times 10^{-4}}{dt}$$

$$I = \frac{E}{R} = \frac{4\pi^2 \times 10^{-4}}{dt \times 20}$$

$$q = \int Idt = \frac{4\pi^2 \times 10^{-4}}{dt \times 20} \times dt = 2 \times 10^{-4} \text{ C.}$$

13. Speed = u

$$\text{Magnetic field} = B$$

$$\text{Side} = a$$

- a) The perpendicular component i.e. $a \sin\theta$ is to be taken which is $\perp r$ to velocity.

$$\text{So, } l = a \sin \theta \ 30^\circ = a/2.$$

$$\text{Net 'a' charge} = 4 \times a/2 = 2a$$

$$\text{So, induced emf} = B\theta l = 2auB$$

b) Current = $\frac{E}{R} = \frac{2auB}{R}$

14. $\phi_1 = 0.35 \text{ weber}, \phi_2 = 0.85 \text{ weber}$

$$D\phi = \phi_2 - \phi_1 = (0.85 - 0.35) \text{ weber} = 0.5 \text{ weber}$$

$$dt = 0.5 \text{ sec}$$

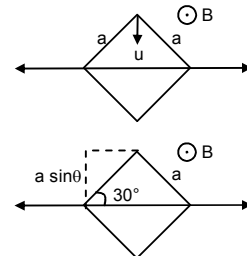

$$E = \frac{d\phi}{dt} = \frac{0.5}{0.5} = 1 \text{ v.}$$

The induced current is anticlockwise as seen from above.

15. $i = v(B \times l)$

$$= v B l \cos\theta$$

$$\theta \text{ is angle between normal to plane and } \vec{B} = 90^\circ.$$

$$= v B l \cos 90^\circ = 0.$$

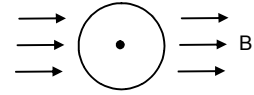

16. $u = 1 \text{ cm/s}$, $B = 0.6 \text{ T}$

a) At $t = 2 \text{ sec}$, distance moved = $2 \times 1 \text{ cm/s} = 2 \text{ cm}$

$$E = \frac{d\phi}{dt} = \frac{0.6 \times (2 \times 5 - 0) \times 10^{-4}}{2} = 3 \times 10^{-4} \text{ V}$$

b) At $t = 10 \text{ sec}$

distance moved = $10 \times 1 = 10 \text{ cm}$

The flux linked does not change with time

$$\therefore E = 0$$

c) At $t = 22 \text{ sec}$

distance = $22 \times 1 = 22 \text{ cm}$

The loop is moving out of the field and 2 cm outside.

$$E = \frac{d\phi}{dt} = B \times \frac{dA}{dt}$$

$$= \frac{0.6 \times (2 \times 5 \times 10^{-4})}{2} = 3 \times 10^{-4} \text{ V}$$

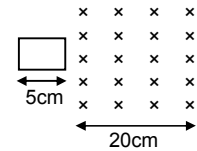

d) At $t = 30 \text{ sec}$

The loop is total outside and flux linked = 0

$$\therefore E = 0.$$

17. As heat produced is a scalar prop.

So, net heat produced = $H_a + H_b + H_c + H_d$

$$R = 4.5 \text{ m}\Omega = 4.5 \times 10^{-3} \Omega$$

a) $e = 3 \times 10^{-4} \text{ V}$

$$i = \frac{e}{R} = \frac{3 \times 10^{-4}}{4.5 \times 10^{-3}} = 6.7 \times 10^{-2} \text{ Amp.}$$

$$H_a = (6.7 \times 10^{-2})^2 \times 4.5 \times 10^{-3} \times 5$$

$$H_b = H_d = 0 \text{ [since emf is induced for 5 sec]}$$

$$H_c = (6.7 \times 10^{-2})^2 \times 4.5 \times 10^{-3} \times 5$$

So Total heat = $H_a + H_c$

$$= 2 \times (6.7 \times 10^{-2})^2 \times 4.5 \times 10^{-3} \times 5 = 2 \times 10^{-4} \text{ J.}$$

18. $r = 10 \text{ cm}$, $R = 4 \Omega$

$$\frac{dB}{dt} = 0.010 \text{ T/s}, \quad \frac{d\phi}{dt} = \frac{dB}{dt} A$$

$$E = \frac{d\phi}{dt} = \frac{dB}{dt} \times A = 0.01 \left(\frac{\pi \times r^2}{2} \right)$$

$$= \frac{0.01 \times 3.14 \times 0.01}{2} = \frac{3.14}{2} \times 10^{-4} = 1.57 \times 10^{-4}$$

$$i = \frac{E}{R} = \frac{1.57 \times 10^{-4}}{4} = 0.39 \times 10^{-4} = 3.9 \times 10^{-5} \text{ A}$$

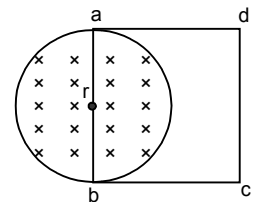

19. a) S_1 closed S_2 open

net $R = 4 + 4 = 16 \Omega$

$$e = \frac{d\phi}{dt} = A \frac{dB}{dt} = 10^{-4} \times 2 \times 10^{-2} = 2 \times 10^{-6} \text{ V}$$

$$i \text{ through } ad = \frac{e}{R} = \frac{2 \times 10^{-6}}{16} = 1.25 \times 10^{-7} \text{ A along } ad$$

b) $R = 16 \ \Omega$

$$e = A \times \frac{dB}{dt} = 2 \times 10^{-5} \text{ V}$$

$$i = \frac{2 \times 10^{-6}}{16} = 1.25 \times 10^{-7} \text{ A along } da$$

c) Since both S_1 and S_2 are open, no current is passed as circuit is open i.e. $i = 0$

d) Since both S_1 and S_2 are closed, the circuit forms a balanced wheat stone bridge and no current will flow along ad i.e. $i = 0$.

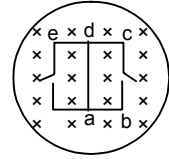

20. Magnetic field due to the coil (1) at the center of (2) is $B = \frac{\mu_0 N i a^2}{2(a^2 + x^2)^{3/2}}$

Flux linked with the second,

$$= B \cdot A_{(2)} = \frac{\mu_0 N i a^2}{2(a^2 + x^2)^{3/2}} \pi a'^2$$

$$\text{E.m.f. induced } \frac{d\phi}{dt} = \frac{\mu_0 N a^2 a'^2 \pi}{2(a^2 + x^2)^{3/2}} \frac{di}{dt}$$

$$= \frac{\mu_0 N \pi a^2 a'^2}{2(a^2 + x^2)^{3/2}} \frac{d}{dt} \left(\frac{E}{(R/L)x + r} \right)$$

$$= \frac{\mu_0 N \pi a^2 a'^2}{2(a^2 + x^2)^{3/2}} E \frac{-1 \cdot R/L \cdot v}{((R/L)x + r)^2}$$

b) $= \frac{\mu_0 N \pi a^2 a'^2}{2(a^2 + x^2)^{3/2}} \frac{ERv}{L(R/2 + r)^2}$ (for $x = L/2$, $R/L x = R/2$)

a) For $x = L$

$$E = \frac{\mu_0 N \pi a^2 a'^2 R v E}{2(a^2 + x^2)^{3/2} (R + r)^2}$$

21. $N = 50$, $\vec{B} = 0.200 \text{ T}$; $r = 2.00 \text{ cm} = 0.02 \text{ m}$

$\theta = 60^\circ$, $t = 0.100 \text{ s}$

a) $e = \frac{Nd\phi}{dt} = \frac{N \times B \cdot A}{T} = \frac{NBA \cos 60^\circ}{T}$

$$= \frac{50 \times 2 \times 10^{-1} \times \pi \times (0.02)^2}{0.1} = 5 \times 4 \times 10^{-3} \times \pi$$

$$= 2\pi \times 10^{-2} \text{ V} = 6.28 \times 10^{-2} \text{ V}$$

b) $i = \frac{e}{R} = \frac{6.28 \times 10^{-2}}{4} = 1.57 \times 10^{-2} \text{ A}$

$$Q = it = 1.57 \times 10^{-2} \times 10^{-1} = 1.57 \times 10^{-3} \text{ C}$$

22. $n = 100$ turns, $B = 4 \times 10^{-4} \text{ T}$

$A = 25 \text{ cm}^2 = 25 \times 10^{-4} \text{ m}^2$

a) When the coil is perpendicular to the field

$$\phi = nBA$$

When coil goes through half a turn

$$\phi = BA \cos 180^\circ = 0 - nBA$$

$$d\phi = 2nBA$$

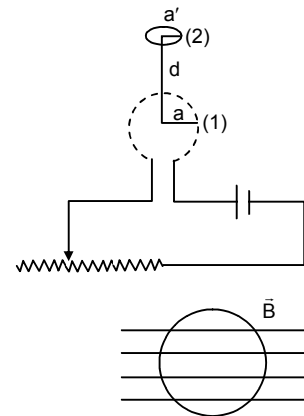

The coil undergoes 300 rev, in 1 min

$$300 \times 2\pi \text{ rad/min} = 10\pi \text{ rad/sec}$$

10π rad is swept in 1 sec.

$$\pi/\pi \text{ rad is swept } 1/10\pi \times \pi = 1/10 \text{ sec}$$

$$E = \frac{d\phi}{dt} = \frac{2nBA}{dt} = \frac{2 \times 100 \times 4 \times 10^{-4} \times 25 \times 10^{-4}}{1/10} = 2 \times 10^{-3} \text{ V}$$

b) $\phi_1 = nBA, \phi_2 = nBA (\theta = 360^\circ)$

$$d\phi = 0$$

c) $i = \frac{E}{R} = \frac{2 \times 10^{-3}}{4} = \frac{1}{2} \times 10^{-3}$

$$= 0.5 \times 10^{-3} = 5 \times 10^{-4}$$

$$q = idt = 5 \times 10^{-4} \times 1/10 = 5 \times 10^{-5} \text{ C.}$$

23. $r = 10 \text{ cm} = 0.1 \text{ m}$

$$R = 40 \Omega, N = 1000$$

$$\theta = 180^\circ, B_H = 3 \times 10^{-5} \text{ T}$$

$$\phi = N(B.A) = NBA \cos 180^\circ \text{ or } -NBA$$

$$= 1000 \times 3 \times 10^{-5} \times \pi \times 1 \times 10^{-2} = 3\pi \times 10^{-4} \text{ where}$$

$$d\phi = 2NBA = 6\pi \times 10^{-4} \text{ weber}$$

$$e = \frac{d\phi}{dt} = \frac{6\pi \times 10^{-4} \text{ V}}{dt}$$

$$i = \frac{6\pi \times 10^{-4}}{40dt} = \frac{4.71 \times 10^{-5}}{dt}$$

$$Q = \frac{4.71 \times 10^{-5} \times dt}{dt} = 4.71 \times 10^{-5} \text{ C.}$$

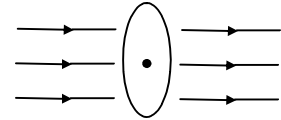

24. $\text{emf} = \frac{d\phi}{dt} = \frac{dB.A \cos \theta}{dt}$

$$= B A \sin \theta \omega = -BA \omega \sin \theta$$

(dq/dt = the rate of change of angle between arc vector and B = ω)

a) $\text{emf maximum} = BA\omega = 0.010 \times 25 \times 10^{-4} \times 80 \times \frac{2\pi \times \pi}{6}$

$$= 0.66 \times 10^{-3} = 6.66 \times 10^{-4} \text{ volt.}$$

b) Since the induced emf changes its direction every time, so for the average emf = 0

25. $H = \int_0^t i^2 R dt = \int_0^t \frac{B^2 A^2 \omega^2}{R^2} \sin^2 \omega t R dt$

$$= \frac{B^2 A^2 \omega^2}{2R^2} \int_0^t (1 - \cos 2\omega t) dt$$

$$= \frac{B^2 A^2 \omega^2}{2R} \left(t - \frac{\sin 2\omega t}{2\omega} \right)_0^{1 \text{ minute}}$$

$$= \frac{B^2 A^2 \omega^2}{2R} \left(60 - \frac{\sin 2 \times 8 - \times 2\pi / 60 \times 60}{2 \times 80 \times 2\pi / 60} \right)$$

$$= \frac{60}{200} \times \pi^2 r^4 \times B^2 \times \left(80^4 \times \frac{2\pi}{60} \right)^2$$

$$= \frac{60}{200} \times 10 \times \frac{64}{9} \times 10 \times 625 \times 10^{-8} \times 10^{-4} = \frac{625 \times 6 \times 64}{9 \times 2} \times 10^{-11} = 1.33 \times 10^{-7} \text{ J.}$$

26. $\phi_1 = BA, \phi_2 = 0$

$$= \frac{2 \times 10^{-4} \times \pi(0.1)^2}{2} = \pi \times 10^{-5}$$

$$E = \frac{d\phi}{dt} = \frac{\pi \times 10^{-6}}{2} = 1.57 \times 10^{-6} \text{ V}$$

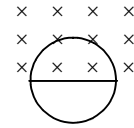

27. $l = 20 \text{ cm} = 0.2 \text{ m}$

$v = 10 \text{ cm/s} = 0.1 \text{ m/s}$

$B = 0.10 \text{ T}$

a) $F = q v B = 1.6 \times 10^{-19} \times 1 \times 10^{-1} \times 1 \times 10^{-1} = 1.6 \times 10^{-21} \text{ N}$

b) $qE = qvB$

$$\Rightarrow E = 1 \times 10^{-1} \times 1 \times 10^{-1} = 1 \times 10^{-2} \text{ V/m}$$

This is created due to the induced emf.

c) Motional emf = $Bv\ell$

$$= 0.1 \times 0.1 \times 0.2 = 2 \times 10^{-3} \text{ V}$$

28. $\ell = 1 \text{ m}, B = 0.2 \text{ T}, v = 2 \text{ m/s}, e = B\ell v$

$$= 0.2 \times 1 \times 2 = 0.4 \text{ V}$$

29. $\ell = 10 \text{ m}, v = 3 \times 10^7 \text{ m/s}, B = 3 \times 10^{-10} \text{ T}$

Motional emf = $Bv\ell$

$$= 3 \times 10^{-10} \times 3 \times 10^7 \times 10 = 9 \times 10^{-3} = 0.09 \text{ V}$$

30. $v = 180 \text{ km/h} = 50 \text{ m/s}$

$B = 0.2 \times 10^{-4} \text{ T}, L = 1 \text{ m}$

$E = Bv\ell = 0.2 \times 10^{-4} \times 50 = 10^{-3} \text{ V}$

\therefore The voltmeter will record 1 mv.

31. a) Zero as the components of ab are exactly opposite to that of bc. So they cancel each other. Because velocity should be perpendicular to the length.

b) $e = Bv \times \ell$

$$= Bv \text{ (bc) +ve at C}$$

c) $e = 0$ as the velocity is not perpendicular to the length.

d) $e = Bv \text{ (bc) positive at 'a'}$

i.e. the component of 'ab' along the perpendicular direction.

32. a) Component of length moving perpendicular to V is $2R$

$$\therefore E = B v 2R$$

b) Component of length perpendicular to velocity = 0

$$\therefore E = 0$$

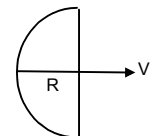
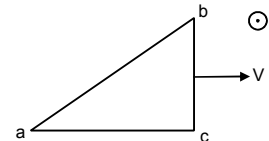

33. $\ell = 10 \text{ cm} = 0.1 \text{ m};$

$\theta = 60^\circ; B = 1 \text{ T}$

$V = 20 \text{ cm/s} = 0.2 \text{ m/s}$

$E = Bv\ell \sin 60^\circ$

[As we have to take that component of length vector which is \perp to the velocity vector]

$$= 1 \times 0.2 \times 0.1 \times \frac{\sqrt{3}}{2}$$

$$= 1.732 \times 10^{-2} = 17.32 \times 10^{-3} \text{ V.}$$

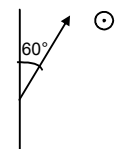

34. a) The e.m.f. is highest between diameter \perp to the velocity. Because here length \perp to velocity is highest.

$$E_{\text{max}} = VB2R$$

b) The length perpendicular to velocity is lowest as the diameter is parallel to the velocity $E_{\text{min}} = 0$.

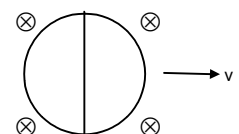

35. $F_{\text{magnetic}} = i\ell B$

This force produces an acceleration of the wire.
But since the velocity is given to be constant.
Hence net force acting on the wire must be zero.

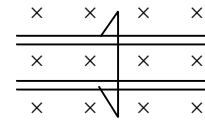

36. $E = Bv\ell$

Resistance = $r \times \text{total length}$
 $= r \times 2(\ell + vt) = 2r(\ell + vt)$

$$i = \frac{Bv\ell}{2r(\ell + vt)}$$

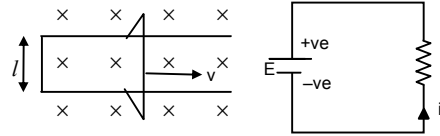

37. $e = Bv\ell$

$$i = \frac{e}{R} = \frac{Bv\ell}{2r(\ell + vt)}$$

a) $F = i\ell B = \frac{Bv\ell}{2r(\ell + vt)} \times \ell B = \frac{B^2\ell^2 v}{2r(\ell + vt)}$

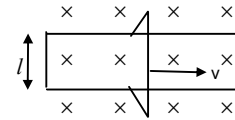

b) Just after $t = 0$

$$F_0 = i\ell B = \ell B \left(\frac{\ell B v}{2r\ell} \right) = \frac{\ell B^2 v}{2r}$$

$$\frac{F_0}{2} = \frac{\ell B^2 v}{4r} = \frac{\ell^2 B^2 v}{2r(\ell + vt)}$$

$$\Rightarrow 2\ell = \ell + vt$$

$$\Rightarrow T = \ell/v$$

38. a) When the speed is V

Emf = $B\ell v$

Resistance = $r + R$

$$\text{Current} = \frac{B\ell v}{r + R}$$

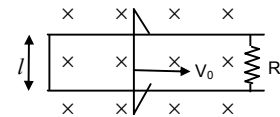

b) Force acting on the wire = $i\ell B$

$$= \frac{B\ell v \ell B}{R + r} = \frac{B^2\ell^2 v}{R + r}$$

$$\text{Acceleration on the wire} = \frac{B^2\ell^2 v}{m(R + r)}$$

c) $v = v_0 + at = v_0 - \frac{B^2\ell^2 v}{m(R + r)} t$ [force is opposite to velocity]

$$= v_0 - \frac{B^2\ell^2 x}{m(R + r)}$$

d) $a = v \frac{dv}{dx} = \frac{B^2\ell^2 v}{m(R + r)}$

$$\Rightarrow dx = \frac{dv m(R + r)}{B^2\ell^2}$$

$$\Rightarrow x = \frac{m(R + r)v_0}{B^2\ell^2}$$

39. $R = 2.0 \Omega$, $B = 0.020 \text{ T}$, $l = 32 \text{ cm} = 0.32 \text{ m}$

$B = 8 \text{ cm} = 0.08 \text{ m}$

a) $F = i\ell B = 3.2 \times 10^{-5} \text{ N}$

$$= \frac{B^2\ell^2 v}{R} = 3.2 \times 10^{-5}$$

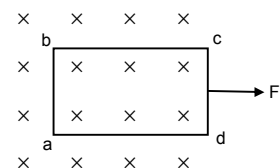

$$\Rightarrow \frac{(0.020)^2 \times (0.08)^2 \times v}{2} = 3.2 \times 10^{-5}$$

$$\Rightarrow v = \frac{3.2 \times 10^{-5} \times 2}{6.4 \times 10^{-3} \times 4 \times 10^{-4}} = 25 \text{ m/s}$$

b) Emf $E = vBl = 25 \times 0.02 \times 0.08 = 4 \times 10^{-2} \text{ V}$

c) Resistance per unit length = $\frac{2}{0.8}$

$$\text{Resistance of part ad/cb} = \frac{2 \times 0.72}{0.8} = 1.8 \Omega$$

$$V_{ab} = iR = \frac{Blv}{2} \times 1.8 = \frac{0.02 \times 0.08 \times 25 \times 1.8}{2} = 0.036 \text{ V} = 3.6 \times 10^{-2} \text{ V}$$

d) Resistance of cd = $\frac{2 \times 0.08}{0.8} = 0.2 \Omega$

$$V = iR = \frac{0.02 \times 0.08 \times 25 \times 0.2}{2} = 4 \times 10^{-3} \text{ V}$$

40. $l = 20 \text{ cm} = 20 \times 10^{-2} \text{ m}$

$$v = 20 \text{ cm/s} = 20 \times 10^{-2} \text{ m/s}$$

$$B_H = 3 \times 10^{-5} \text{ T}$$

$$i = 2 \mu\text{A} = 2 \times 10^{-6} \text{ A}$$

$$R = 0.2 \Omega$$

$$i = \frac{B_v l v}{R}$$

$$\Rightarrow B_v = \frac{iR}{l v} = \frac{2 \times 10^{-6} \times 2 \times 10^{-1}}{20 \times 10^{-2} \times 20 \times 10^{-2}} = 1 \times 10^{-5} \text{ Tesla}$$

$$\tan \delta = \frac{B_v}{B_H} = \frac{1 \times 10^{-5}}{3 \times 10^{-5}} = \frac{1}{3} \Rightarrow \delta(\text{dip}) = \tan^{-1}(1/3)$$

41. $I = \frac{Blv}{R} = \frac{B \times l \cos \theta \times v \cos \theta}{R}$

$$= \frac{Blv}{R} \cos^2 \theta$$

$$F = i l B = \frac{Blv \cos^2 \theta \times l B}{R}$$

Now, $F = mg \sin \theta$ [Force due to gravity which pulls downwards]

$$\text{Now, } \frac{B^2 l^2 v \cos^2 \theta}{R} = mg \sin \theta$$

$$\Rightarrow B = \sqrt{\frac{Rmg \sin \theta}{l^2 v \cos^2 \theta}}$$

42. a) The wires constitute 2 parallel emf.

$$\therefore \text{Net emf} = Blv = 1 \times 4 \times 10^{-2} \times 5 \times 10^{-2} = 20 \times 10^{-4}$$

$$\text{Net resistance} = \frac{2 \times 2}{2 + 2} + 19 = 20 \Omega$$

$$\text{Net current} = \frac{20 \times 10^{-4}}{20} = 0.1 \text{ mA.}$$

b) When both the wires move towards opposite directions then not emf = 0

$$\therefore \text{Net current} = 0$$

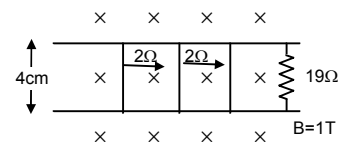
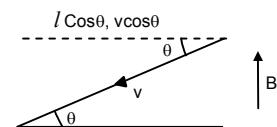
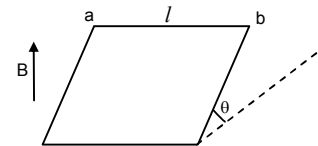

43.

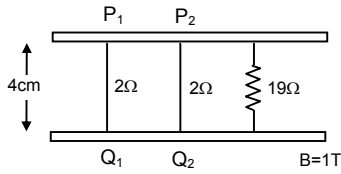

- a) No current will pass as circuit is incomplete.
 b) As circuit is complete

$$V_{P_2Q_2} = B \ell v$$

$$= 1 \times 0.04 \times 0.05 = 2 \times 10^{-3} \text{ V}$$

$$R = 2\Omega$$

$$i = \frac{2 \times 10^{-3}}{2} = 1 \times 10^{-3} \text{ A} = 1 \text{ mA.}$$

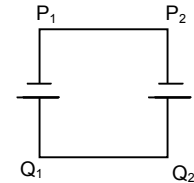
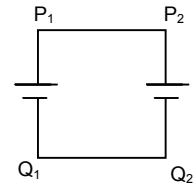

44. $B = 1 \text{ T}$, $v = 5 \text{ l } 10^{-2} \text{ m/s}$, $R = 10 \Omega$

- a) When the switch is thrown to the middle rail

$$E = Bv\ell$$

$$= 1 \times 5 \times 10^{-2} \times 2 \times 10^{-2} = 10^{-3}$$

Current in the 10Ω resistor $= E/R$

$$= \frac{10^{-3}}{10} = 10^{-4} = 0.1 \text{ mA}$$

- b) The switch is thrown to the lower rail

$$E = Bv\ell$$

$$= 1 \times 5 \times 10^{-2} \times 2 \times 10^{-2} = 20 \times 10^{-4}$$

Current $= \frac{20 \times 10^{-4}}{10} = 2 \times 10^{-4} = 0.2 \text{ mA}$

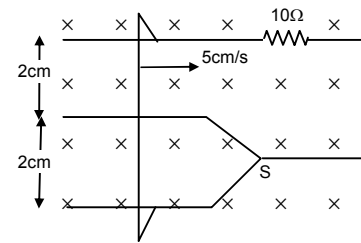

45. Initial current passing = i

Hence initial emf = ir
 Emf due to motion of $ab = B\ell v$
 Net emf = $ir - B\ell v$
 Net resistance = $2r$

Hence current passing = $\frac{ir - B\ell v}{2r}$

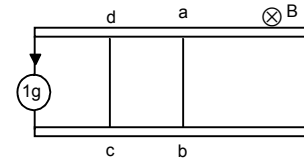

46. Force on the wire = $i\ell B$

$$\text{Acceleration} = \frac{i\ell B}{m}$$

$$\text{Velocity} = \frac{i\ell B t}{m}$$

47. Given $B\ell v = mg$... (1)

When wire is released we have
 $2mg - B\ell v = 2ma$ [where $a \rightarrow$ acceleration]

$$\Rightarrow a = \frac{2mg - B\ell v}{2m}$$

$$\text{Now, } s = ut + \frac{1}{2}at^2$$

$$\Rightarrow \ell = \frac{1}{2} \times \frac{2mg - B\ell v}{2m} \times t^2 \quad [\because s = \ell]$$

$$\Rightarrow t = \sqrt{\frac{4m\ell}{2mg - B\ell v}} = \sqrt{\frac{4m\ell}{2mg - mg}} = \sqrt{2\ell/g} \quad [\text{from (1)}]$$

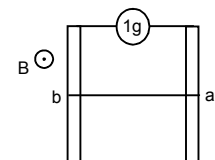
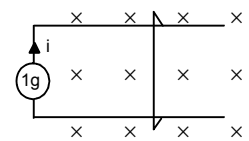

48. a) emf developed = Bdv (when it attains a speed v)

$$\text{Current} = \frac{Bdv}{R}$$

$$\text{Force} = \frac{Bd^2v^2}{R}$$

This force opposes the given force

$$\text{Net } F = F - \frac{Bd^2v^2}{R} = RF - \frac{Bd^2v^2}{R}$$

$$\text{Net acceleration} = \frac{RF - B^2d^2v}{mR}$$

b) Velocity becomes constant when acceleration is 0.

$$\frac{F}{m} - \frac{B^2d^2v_0}{mR} = 0$$

$$\Rightarrow \frac{F}{m} = \frac{B^2d^2v_0}{mR}$$

$$\Rightarrow v_0 = \frac{FR}{B^2d^2}$$

c) Velocity at line t

$$a = -\frac{dv}{dt}$$

$$\Rightarrow \int_0^v \frac{dv}{RF - l^2B^2v} = \int_0^t \frac{dt}{mR}$$

$$\Rightarrow \left[\ln \left[\frac{RF - l^2B^2v}{-l^2B^2} \right] \right]_0^v = \left[\frac{t}{Rm} \right]_0^t$$

$$\Rightarrow \left[\ln(RF - l^2B^2v) \right]_0^v = \frac{-t^2B^2}{Rm}$$

$$\Rightarrow \ln(RF - l^2B^2v) - \ln(RF) = \frac{-t^2B^2}{Rm}$$

$$\Rightarrow 1 - \frac{l^2B^2v}{RF} = e^{-\frac{t^2B^2}{Rm}}$$

$$\Rightarrow \frac{l^2B^2v}{RF} = 1 - e^{-\frac{t^2B^2}{Rm}}$$

$$\Rightarrow v = \frac{FR}{l^2B^2} \left(1 - e^{-\frac{l^2B^2v_0t}{Rv_0m}} \right) = v_0(1 - e^{-Fv_0t/m})$$

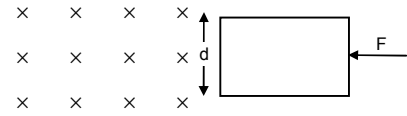

49. Net emf = $E - Bv\ell$

$$I = \frac{E - Bv\ell}{r} \text{ from b to a}$$

$$F = I \ell B$$

$$= \left(\frac{E - Bv\ell}{r} \right) \ell B = \frac{\ell B}{r} (E - Bv\ell) \text{ towards right.}$$

After some time when $E = Bv\ell$,

Then the wire moves constant velocity v

Hence $v = E / B\ell$.

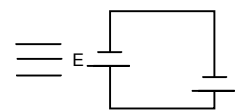
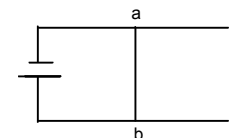

50. a) When the speed of wire is V
emf developed = $B \ell V$

b) Induced current in the wire = $\frac{B \ell v}{R}$ (from b to a)

c) Downward acceleration of the wire

$$= \frac{mg - F}{m} \text{ due to the current}$$

$$= mg - i \ell B/m = g - \frac{B^2 \ell^2 v}{Rm}$$

d) Let the wire start moving with constant velocity. Then acceleration = 0

$$\frac{B^2 \ell^2 v}{Rm} m = g$$

$$\Rightarrow v_m = \frac{gRm}{B^2 \ell^2}$$

e) $\frac{dv}{dt} = a$

$$\Rightarrow \frac{dv}{dt} = \frac{mg - B^2 \ell^2 v / R}{m}$$

$$\Rightarrow \frac{dv}{mg - B^2 \ell^2 v / R} = dt$$

$$\Rightarrow \int_0^v \frac{mdv}{mg - \frac{B^2 \ell^2 v}{R}} = \int_0^t dt$$

$$\Rightarrow \frac{m}{-B^2 \ell^2} \left(\log \left(mg - \frac{B^2 \ell^2 v}{R} \right) \right)_0^v = t$$

$$\Rightarrow \frac{-mR}{B^2 \ell^2} = \log \left[\log \left(mg - \frac{B^2 \ell^2 v}{R} \right) - \log(mg) \right] = t$$

$$\Rightarrow \log \left[\frac{mg - \frac{B^2 \ell^2 v}{R}}{mg} \right] = \frac{-tB^2 \ell^2}{mR}$$

$$\Rightarrow \log \left[1 - \frac{B^2 \ell^2 v}{Rmg} \right] = \frac{-tB^2 \ell^2}{mR}$$

$$\Rightarrow 1 - \frac{B^2 \ell^2 v}{Rmg} = e^{\frac{-tB^2 \ell^2}{mR}}$$

$$\Rightarrow (1 - e^{-B^2 \ell^2 t / mR}) = \frac{B^2 \ell^2 v}{Rmg}$$

$$\Rightarrow v = \frac{Rmg}{B^2 \ell^2} (1 - e^{-B^2 \ell^2 t / mR})$$

$$\Rightarrow v = v_m (1 - e^{-gt / v_m}) \quad \left[v_m = \frac{Rmg}{B^2 \ell^2} \right]$$

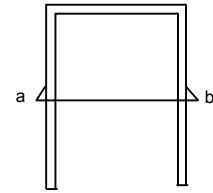

f) $\frac{ds}{dt} = v \Rightarrow ds = v dt$
 $\Rightarrow s = v_m \int_0^t (1 - e^{-gt/v_m}) dt$
 $= v_m \left(t - \frac{v_m}{g} e^{-gt/v_m} \right) = \left(v_m t + \frac{v_m^2}{g} e^{-gt/v_m} \right) - \frac{v_m^2}{g}$
 $= v_m t - \frac{v_m^2}{g} (1 - e^{-gt/v_m})$

g) $\frac{d}{dt} mgs = mg \frac{ds}{dt} = mg v_m (1 - e^{-gt/v_m})$
 $\frac{dH}{dt} = i^2 R = R \left(\frac{\ell B v}{R} \right)^2 = \frac{\ell^2 B^2 v^2}{R}$

$\Rightarrow \frac{\ell^2 B^2}{R} v_m^2 (1 - e^{-gt/v_m})^2$

After steady state i.e. $T \rightarrow \infty$

$\frac{d}{dt} mgs = mg v_m$

$\frac{dH}{dt} = \frac{\ell^2 B^2}{R} v_m^2 = \frac{\ell^2 B^2}{R} v_m \frac{mgR}{\ell^2 B^2} = mg v_m$

Hence after steady state $\frac{dH}{dt} = \frac{d}{dt} mgs$

51. $\ell = 0.3 \text{ m}$, $\vec{B} = 2.0 \times 10^{-5} \text{ T}$, $\omega = 100 \text{ rpm}$

$v = \frac{100}{60} \times 2\pi = \frac{10}{3} \pi \text{ rad/s}$

$v = \frac{\ell}{2} \times \omega = \frac{0.3}{2} \times \frac{10}{3} \pi$

Emf = $e = B\ell v$

$= 2.0 \times 10^{-5} \times 0.3 \times \frac{0.33}{2} \times \frac{10}{3} \pi$
 $= 3\pi \times 10^{-6} \text{ V} = 3 \times 3.14 \times 10^{-6} \text{ V} = 9.42 \times 10^{-6} \text{ V}$

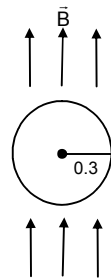

52. v at a distance $r/2$

From the centre = $\frac{r\omega}{2}$

$E = B\ell v \Rightarrow E = B \times r \times \frac{r\omega}{2} = \frac{1}{2} Br^2 \omega$

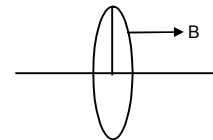

53. $B = 0.40 \text{ T}$, $\omega = 10 \text{ rad/s}$, $r = 10 \Omega$

$r = 5 \text{ cm} = 0.05 \text{ m}$

Considering a rod of length 0.05 m affixed at the centre and rotating with the same ω .

$v = \frac{\ell}{2} \times \omega = \frac{0.05}{2} \times 10$

$e = B\ell v = 0.40 \times \frac{0.05}{2} \times 10 \times 0.05 = 5 \times 10^{-3} \text{ V}$

$I = \frac{e}{R} = \frac{5 \times 10^{-3}}{10} = 0.5 \text{ mA}$

It leaves from the centre.

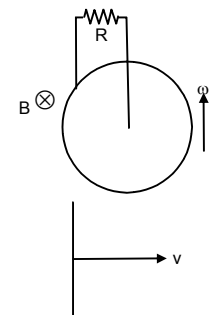

54. $\vec{B} = \frac{B_0}{L} y \hat{k}$

L = Length of rod on y-axis

$V = V_0 \hat{i}$

Considering a small length by of the rod

$dE = B V dy$

$\Rightarrow dE = \frac{B_0}{L} y \times V_0 \times dy$

$\Rightarrow dE = \frac{B_0 V_0}{L} y dy$

$\Rightarrow E = \frac{B_0 V_0}{L} \int_0^L y dy$

$= \frac{B_0 V_0}{L} \left[\frac{y^2}{2} \right]_0^L = \frac{B_0 V_0}{L} \frac{L^2}{2} = \frac{1}{2} B_0 V_0 L$

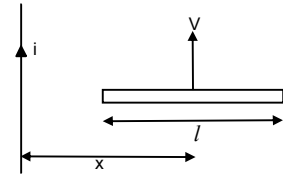

55. In this case \vec{B} varies

Hence considering a small element at centre of rod of length dx at a dist x from the wire.

$\vec{B} = \frac{\mu_0 i}{2\pi x}$

So, $de = \frac{\mu_0 i}{2\pi x} \times v dx$

$e = \int_0^e de = \frac{\mu_0 i v}{2\pi} = \int_{x-l/2}^{x+l/2} \frac{dx}{x} = \frac{\mu_0 i v}{2\pi} [\ln(x + l/2) - \ln(x - l/2)]$

$= \frac{\mu_0 i v}{2\pi} \ln \left[\frac{x + l/2}{x - l/2} \right] = \frac{\mu_0 i v}{2\pi} \ln \left(\frac{2x + l}{2x - l} \right)$

56. a) emf produced due to the current carrying wire = $\frac{\mu_0 i v}{2\pi} \ln \left(\frac{2x + l}{2x - l} \right)$

Let current produced in the rod = $i' = \frac{\mu_0 i v}{2\pi R} \ln \left(\frac{2x + l}{2x - l} \right)$

Force on the wire considering a small portion dx at a distance x

$dF = i' B l$

$\Rightarrow dF = \frac{\mu_0 i v}{2\pi R} \ln \left(\frac{2x + l}{2x - l} \right) \times \frac{\mu_0 i}{2\pi x} \times dx$

$\Rightarrow dF = \left(\frac{\mu_0 i}{2\pi} \right)^2 \frac{v}{R} \ln \left(\frac{2x + l}{2x - l} \right) \frac{dx}{x}$

$\Rightarrow F = \left(\frac{\mu_0 i}{2\pi} \right)^2 \frac{v}{R} \ln \left(\frac{2x + l}{2x - l} \right) \int_{x-l/2}^{x+l/2} \frac{dx}{x}$

$= \left(\frac{\mu_0 i}{2\pi} \right)^2 \frac{v}{R} \ln \left(\frac{2x + l}{2x - l} \right) \ln \left(\frac{2x + l}{2x - l} \right)$

$= \frac{v}{R} \left[\frac{\mu_0 i}{2\pi} \ln \left(\frac{2x + l}{2x - l} \right) \right]^2$

b) Current = $\frac{\mu_0 i v}{2\pi R} \ln \left(\frac{2x + l}{2x - l} \right)$

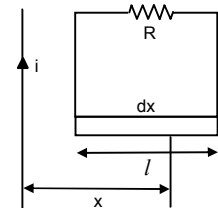

c) Rate of heat developed = $i^2 R$

$$= \left[\frac{\mu_0 i V}{2\pi R} \ln \left(\frac{2x + \ell}{2x - \ell} \right) \right]^2 R = \frac{1}{R} \left[\frac{\mu_0 i V}{2\pi} \ln \left(\frac{2x + \ell}{2x - \ell} \right) \right]^2$$

d) Power developed in rate of heat developed = $i^2 R$

$$= \frac{1}{R} \left[\frac{\mu_0 i V}{2\pi} \ln \left(\frac{2x + \ell}{2x - \ell} \right) \right]^2$$

57. Considering an element dx at a dist x from the wire. We have

a) $\phi = B.A.$

$$d\phi = \frac{\mu_0 i \times adx}{2\pi x}$$

$$\phi = \int_0^a d\phi = \frac{\mu_0 ia}{2\pi} \int_b^{a+b} \frac{dx}{x} = \frac{\mu_0 ia}{2\pi} \ln\{1 + a/b\}$$

b) $e = \frac{d\phi}{dt} = \frac{d}{dt} \frac{\mu_0 ia}{2\pi} \ln\{1 + a/b\}$

$$= \frac{\mu_0 a}{2\pi} \ln\{1 + a/b\} \frac{d}{dt} (i_0 \sin \omega t)$$

$$= \frac{\mu_0 a i_0 \omega \cos \omega t}{2\pi} \ln\{1 + a/b\}$$

c) $i = \frac{e}{r} = \frac{\mu_0 a i_0 \omega \cos \omega t}{2\pi r} \ln\{1 + a/b\}$

$$H = i^2 r t$$

$$= \left[\frac{\mu_0 a i_0 \omega \cos \omega t}{2\pi r} \ln\{1 + a/b\} \right]^2 \times r \times t$$

$$= \frac{\mu_0^2 \times a^2 \times i_0^2 \times \omega^2}{4\pi \times r^2} \ln^2\{1 + a/b\} \times r \times \frac{20\pi}{\omega}$$

$$= \frac{5\mu_0^2 a^2 i_0^2 \omega}{2\pi r} \ln^2\{1 + a/b\} \quad [\because t = \frac{20\pi}{\omega}]$$

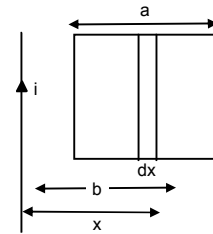

58. a) Using Faraday' law

Consider a unit length dx at a distance x

$$B = \frac{\mu_0 i}{2\pi x}$$

Area of strip = $b dx$

$$d\phi = \frac{\mu_0 i}{2\pi x} dx$$

$$\Rightarrow \phi = \int_a^{a+l} \frac{\mu_0 i}{2\pi x} b dx$$

$$= \frac{\mu_0 i}{2\pi} b \int_a^{a+l} \left(\frac{dx}{x} \right) = \frac{\mu_0 i b}{2\pi} \log \left(\frac{a+l}{a} \right)$$

$$Emf = \frac{d\phi}{dt} = \frac{d}{dt} \left[\frac{\mu_0 i b}{2\pi} \log \left(\frac{a+l}{a} \right) \right]$$

$$= \frac{\mu_0 i b}{2\pi} \frac{a}{a+l} \left(\frac{va - (a+l)v}{a^2} \right) \quad (\text{where } da/dt = V)$$

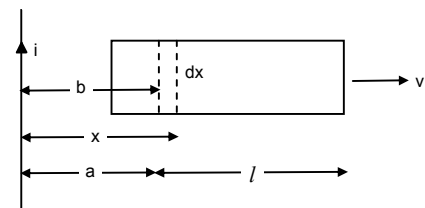

$$= \frac{\mu_0 i b}{2\pi} \frac{a}{a+l} \frac{v l}{a^2} = \frac{\mu_0 i b v l}{2\pi(a+l)a}$$

The velocity of AB and CD creates the emf. since the emf due to AD and BC are equal and opposite to each other.

$$B_{AB} = \frac{\mu_0 i}{2\pi a} \Rightarrow \text{E.m.f. AB} = \frac{\mu_0 i}{2\pi a} b v$$

Length b, velocity v.

$$B_{CD} = \frac{\mu_0 i}{2\pi(a+l)}$$

$$\Rightarrow \text{E.m.f. CD} = \frac{\mu_0 i b v}{2\pi(a+l)}$$

Length b, velocity v.

$$\text{Net emf} = \frac{\mu_0 i}{2\pi a} b v - \frac{\mu_0 i b v}{2\pi(a+l)} = \frac{\mu_0 i b v l}{2\pi a(a+l)}$$

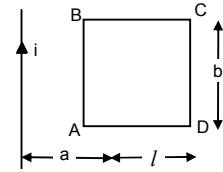

59. $e = Bvl = \frac{B \times a \times \omega \times a}{2}$

$$i = \frac{Ba^2\omega}{2R}$$

$$F = i\ell B = \frac{Ba^2\omega}{2R} \times a \times B = \frac{B^2 a^3 \omega}{2R} \text{ towards right of OA.}$$

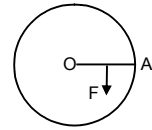

60. The 2 resistances r/4 and 3r/4 are in parallel.

$$R' = \frac{r/4 \times 3r/4}{r} = \frac{3r}{16}$$

$$e = BV\ell$$

$$= B \times \frac{a}{2} \omega \times a = \frac{Ba^2\omega}{2}$$

$$i = \frac{e}{R'} = \frac{Ba^2\omega}{2R'} = \frac{Ba^2\omega}{2 \times 3r/16}$$

$$= \frac{Ba^2\omega 16}{2 \times 3r} = \frac{8 Ba^2\omega}{3 r}$$

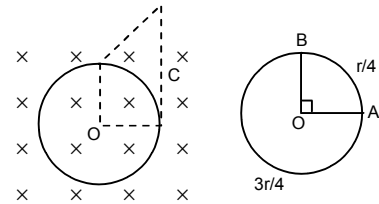

61. We know

$$F = \frac{B^2 a^2 \omega}{2R} = i\ell B$$

Component of mg along F = mg sin theta.

$$\text{Net force} = \frac{B^2 a^3 \omega}{2R} - mg \sin \theta.$$

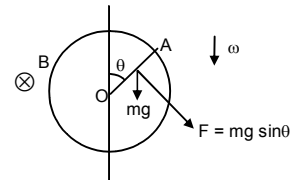

62. $\text{emf} = \frac{1}{2} B\omega a^2$ [from previous problem]

$$\text{Current} = \frac{e + E}{R} = \frac{1/2 \times B\omega a^2 + E}{R} = \frac{B\omega a^2 + 2E}{2R}$$

$$\Rightarrow mg \cos \theta = i\ell B \text{ [Net force acting on the rod is O]}$$

$$\Rightarrow mg \cos \theta = \frac{B\omega a^2 + 2E}{2R} a \times B$$

$$\Rightarrow R = \frac{(B\omega a^2 + 2E)aB}{2mg \cos \theta}.$$

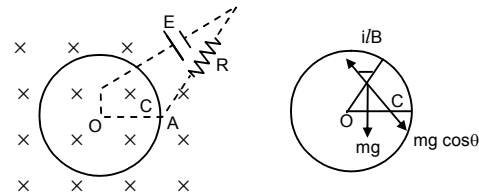

63. Let the rod has a velocity v at any instant,

Then, at the point,

$$e = Blv$$

Now, $q = c \times \text{potential} = ce = CB\ell v$

$$\text{Current } I = \frac{dq}{dt} = \frac{d}{dt} CB\ell v$$

$$= CBI \frac{dv}{dt} = CBIa \quad (\text{where } a \rightarrow \text{acceleration})$$

From figure, force due to magnetic field and gravity are opposite to each other.

So, $mg - I\ell B = ma$

$$\Rightarrow mg - CB\ell a \times \ell B = ma \Rightarrow ma + CB^2\ell^2 a = mg$$

$$\Rightarrow a(m + CB^2\ell^2) = mg \Rightarrow a = \frac{mg}{m + CB^2\ell^2}$$

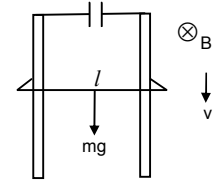

64. a) Work done per unit test charge

$$= \oint E \cdot dl \quad (E = \text{electric field})$$

$$\oint E \cdot dl = e$$

$$\Rightarrow E \oint dl = \frac{d\phi}{dt} \Rightarrow E 2\pi r = \frac{dB}{dt} \times A$$

$$\Rightarrow E 2\pi r = \pi r^2 \frac{dB}{dt}$$

$$\Rightarrow E = \frac{\pi r^2}{2\pi} \frac{dB}{dt} = \frac{r}{2} \frac{dB}{dt}$$

b) When the square is considered,

$$\oint E \cdot dl = e$$

$$\Rightarrow E \times 2r \times 4 = \frac{dB}{dt} (2r)^2$$

$$\Rightarrow E = \frac{dB}{dt} \frac{4r^2}{8r} \Rightarrow E = \frac{r}{2} \frac{dB}{dt}$$

\therefore The electric field at the point p has the same value as (a).

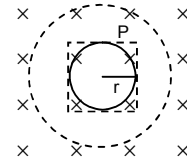

65. $\frac{di}{dt} = 0.01 \text{ A/s}$

For $2s \frac{di}{dt} = 0.02 \text{ A/s}$

$n = 2000 \text{ turn/m}$, $R = 6.0 \text{ cm} = 0.06 \text{ m}$

$r = 1 \text{ cm} = 0.01 \text{ m}$

a) $\phi = BA$

$$\Rightarrow \frac{d\phi}{dt} = \mu_0 n A \frac{di}{dt}$$

$$= 4\pi \times 10^{-7} \times 2 \times 10^3 \times \pi \times 1 \times 10^{-4} \times 2 \times 10^{-2} \quad [A = \pi \times 1 \times 10^{-4}]$$

$$= 16\pi^2 \times 10^{-10} \omega$$

$$= 157.91 \times 10^{-10} \omega$$

$$= 1.6 \times 10^{-8} \omega$$

$$\text{or, } \frac{d\phi}{dt} \text{ for } 1 \text{ s} = 0.785 \omega.$$

b) $\int E \cdot dl = \frac{d\phi}{dt}$

$$\Rightarrow E\phi dl = \frac{d\phi}{dt} \Rightarrow E = \frac{0.785 \times 10^{-8}}{2\pi \times 10^{-2}} = 1.2 \times 10^{-7} \text{ V/m}$$

c) $\frac{d\phi}{dt} = \mu_0 n \frac{di}{dt} A = 4\pi \times 10^{-7} \times 2000 \times 0.01 \times \pi \times (0.06)^2$

$$E\phi dl = \frac{d\phi}{dt}$$

$$\Rightarrow E = \frac{d\phi/dt}{2\pi r} = \frac{4\pi \times 10^{-7} \times 2000 \times 0.01 \times \pi \times (0.06)^2}{\pi \times 8 \times 10^{-2}} = 5.64 \times 10^{-7} \text{ V/m}$$

66. $V = 20 \text{ V}$

$$dl = I_2 - I_1 = 2.5 - (-2.5) = 5 \text{ A}$$

$$dt = 0.1 \text{ s}$$

$$V = L \frac{dl}{dt}$$

$$\Rightarrow 20 = L(5/0.1) \Rightarrow 20 = L \times 50$$

$$\Rightarrow L = 20 / 50 = 4/10 = 0.4 \text{ Henry.}$$

67. $\frac{d\phi}{dt} = 8 \times 10^{-4} \text{ weber}$

$$n = 200, I = 4 \text{ A, } E = -nL \frac{dl}{dt}$$

$$\text{or, } \frac{-d\phi}{dt} = \frac{-Ldl}{dt}$$

$$\text{or, } L = n \frac{d\phi}{dt} = 200 \times 8 \times 10^{-4} = 2 \times 10^{-2} \text{ H.}$$

68. $E = \frac{\mu_0 N^2 A}{\ell} \frac{dl}{dt}$

$$= \frac{4\pi \times 10^{-7} \times (240)^2 \times \pi (2 \times 10^{-2})^2}{12 \times 10^{-2}} \times 0.8$$

$$= \frac{4\pi \times (24)^2 \times \pi \times 4 \times 8}{12} \times 10^{-8}$$

$$= 60577.3824 \times 10^{-8} = 6 \times 10^{-4} \text{ V.}$$

69. We know $i = i_0 (1 - e^{-t/r})$

a) $\frac{90}{100} i_0 = i_0 (1 - e^{-t/r})$

$$\Rightarrow 0.9 = 1 - e^{-t/r}$$

$$\Rightarrow e^{-t/r} = 0.1$$

Taking \ln from both sides

$$\ln e^{-t/r} = \ln 0.1 \Rightarrow -t = -2.3 \Rightarrow t/r = 2.3$$

b) $\frac{99}{100} i_0 = i_0 (1 - e^{-t/r})$

$$\Rightarrow e^{-t/r} = 0.01$$

$$\ln e^{-t/r} = \ln 0.01$$

$$\text{or, } -t/r = -4.6 \quad \text{or } t/r = 4.6$$

c) $\frac{99.9}{100} i_0 = i_0 (1 - e^{-t/r})$

$$e^{-t/r} = 0.001$$

$$\Rightarrow \ln e^{-t/r} = \ln 0.001 \Rightarrow e^{-t/r} = -6.9 \Rightarrow t/r = 6.9.$$

70. $i = 2A, E = 4V, L = 1H$

$$R = \frac{E}{i} = \frac{4}{2} = 2$$

$$i = \frac{L}{R} = \frac{1}{2} = 0.5$$

71. $L = 2.0 H, R = 20 \Omega, \text{emf} = 4.0 V, t = 0.20 S$

$$i_0 = \frac{e}{R} = \frac{4}{20}, \tau = \frac{L}{R} = \frac{2}{20} = 0.1$$

$$\text{a) } i = i_0 (1 - e^{-t/\tau}) = \frac{4}{20} (1 - e^{-0.2/0.1})$$

$$= 0.17 A$$

$$\text{b) } \frac{1}{2} Li^2 = \frac{1}{2} \times 2 \times (0.17)^2 = 0.0289 = 0.03 J.$$

72. $R = 40 \Omega, E = 4V, t = 0.1, i = 63 \text{ mA}$

$$i = i_0 (1 - e^{-tR/L})$$

$$\Rightarrow 63 \times 10^{-3} = 4/40 (1 - e^{-0.1 \times 40/L})$$

$$\Rightarrow 63 \times 10^{-3} = 10^{-1} (1 - e^{-4/L})$$

$$\Rightarrow 63 \times 10^{-2} = (1 - e^{-4/L})$$

$$\Rightarrow 1 - 0.63 = e^{-4/L} \Rightarrow e^{-4/L} = 0.37$$

$$\Rightarrow -4/L = \ln(0.37) = -0.994$$

$$\Rightarrow L = \frac{-4}{-0.994} = 4.024 H = 4 H.$$

73. $L = 5.0 H, R = 100 \Omega, \text{emf} = 2.0 V$

$$t = 20 \text{ ms} = 20 \times 10^{-3} \text{ s} = 2 \times 10^{-2} \text{ s}$$

$$i_0 = \frac{2}{100} \quad \text{now } i = i_0 (1 - e^{-t/\tau})$$

$$\tau = \frac{L}{R} = \frac{5}{100} \Rightarrow i = \frac{2}{100} \left(1 - e^{-\frac{2 \times 10^{-2} \times 100}{5}} \right)$$

$$\Rightarrow i = \frac{2}{100} (1 - e^{-2/5})$$

$$\Rightarrow 0.00659 = 0.0066.$$

$$V = iR = 0.0066 \times 100 = 0.66 V.$$

74. $\tau = 40 \text{ ms}$

$$i_0 = 2 A$$

a) $t = 10 \text{ ms}$

$$i = i_0 (1 - e^{-t/\tau}) = 2(1 - e^{-10/40}) = 2(1 - e^{-1/4})$$

$$= 2(1 - 0.7788) = 2(0.2211)^A = 0.4422 A = 0.44 A$$

b) $t = 20 \text{ ms}$

$$i = i_0 (1 - e^{-t/\tau}) = 2(1 - e^{-20/40}) = 2(1 - e^{-1/2})$$

$$= 2(1 - 0.606) = 0.7869 A = 0.79 A$$

c) $t = 100 \text{ ms}$

$$i = i_0 (1 - e^{-t/\tau}) = 2(1 - e^{-100/40}) = 2(1 - e^{-10/4})$$

$$= 2(1 - 0.082) = 1.835 A = 1.8 A$$

d) $t = 1 \text{ s}$

$$i = i_0 (1 - e^{-t/\tau}) = 2(1 - e^{-1/40 \times 10^{-3}}) = 2(1 - e^{-10/40})$$

$$= 2(1 - e^{-25}) = 2 \times 1 = 2 A$$

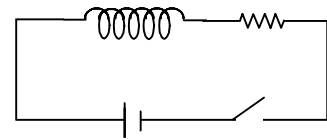

75. $L = 1.0 \text{ H}$, $R = 20 \Omega$, $\text{emf} = 2.0 \text{ V}$

$$\tau = \frac{L}{R} = \frac{1}{20} = 0.05$$

$$i_0 = \frac{e}{R} = \frac{2}{20} = 0.1 \text{ A}$$

$$i = i_0 (1 - e^{-t}) = i_0 - i_0 e^{-t}$$

$$\Rightarrow \frac{di}{dt} = \frac{di_0}{dt} (i_0 \times -1/\tau \times e^{-t/\tau}) = i_0 / \tau e^{-t/\tau}$$

So,

a) $t = 100 \text{ ms} \Rightarrow \frac{di}{dt} = \frac{0.1}{0.05} \times e^{-0.1/0.05} = 0.27 \text{ A}$

b) $t = 200 \text{ ms} \Rightarrow \frac{di}{dt} = \frac{0.1}{0.05} \times e^{-0.2/0.05} = 0.0366 \text{ A}$

c) $t = 1 \text{ s} \Rightarrow \frac{di}{dt} = \frac{0.1}{0.05} \times e^{-1/0.05} = 4 \times 10^{-9} \text{ A}$

76. a) For first case at $t = 100 \text{ ms}$

$$\frac{di}{dt} = 0.27$$

$$\text{Induced emf} = L \frac{di}{dt} = 1 \times 0.27 = 0.27 \text{ V}$$

b) For the second case at $t = 200 \text{ ms}$

$$\frac{di}{dt} = 0.036$$

$$\text{Induced emf} = L \frac{di}{dt} = 1 \times 0.036 = 0.036 \text{ V}$$

c) For the third case at $t = 1 \text{ s}$

$$\frac{di}{dt} = 4.1 \times 10^{-9} \text{ V}$$

$$\text{Induced emf} = L \frac{di}{dt} = 4.1 \times 10^{-9} \text{ V}$$

77. $L = 20 \text{ mH}$; $e = 5.0 \text{ V}$, $R = 10 \Omega$

$$\tau = \frac{L}{R} = \frac{20 \times 10^{-3}}{10}, i_0 = \frac{5}{10}$$

$$i = i_0 (1 - e^{-t/\tau})^2$$

$$\Rightarrow i = i_0 - i_0 e^{-t/\tau^2}$$

$$\Rightarrow iR = i_0 R - i_0 R e^{-t/\tau^2}$$

a) $10 \times \frac{di}{dt} = \frac{d}{dt} i_0 R + 10 \times \frac{5}{10} \times \frac{10}{20 \times 10^{-3}} \times e^{-0.1/2 \times 10^{-2}}$
 $= \frac{5}{2} \times 10^{-3} \times 1 = \frac{5000}{2} = 2500 = 2.5 \times 10^{-3} \text{ V/s.}$

b) $\frac{R di}{dt} = R \times i_0 \times \frac{1}{\tau} \times e^{-t/\tau}$

$$t = 10 \text{ ms} = 10 \times 10^{-3} \text{ s}$$

$$\frac{dE}{dt} = 10 \times \frac{5}{10} \times \frac{10}{20 \times 10^{-3}} \times e^{-0.01 \times 10 / 2 \times 10^{-2}}$$

$$= 16.844 = 17 \text{ V/s}$$

c) For $t = 1$ s

$$\frac{dE}{dt} = \frac{R di}{dt} = \frac{5}{2} 10^3 \times e^{10/2 \times 10^{-2}} = 0.00 \text{ V/s.}$$

78. $L = 500$ mH, $R = 25 \Omega$, $E = 5$ V

a) $t = 20$ ms

$$\begin{aligned} i &= i_0 (1 - e^{-tR/L}) = \frac{E}{R} (1 - e^{-tR/L}) \\ &= \frac{5}{25} \left(1 - e^{-20 \times 10^{-3} \times 25 / 500 \times 10^{-3}} \right) = \frac{1}{5} (1 - e^{-1}) \\ &= \frac{1}{5} (1 - 0.3678) = 0.1264 \end{aligned}$$

Potential difference $iR = 0.1264 \times 25 = 3.1606 \text{ V} = 3.16 \text{ V}$.

b) $t = 100$ ms

$$\begin{aligned} i &= i_0 (1 - e^{-tR/L}) = \frac{E}{R} (1 - e^{-tR/L}) \\ &= \frac{5}{25} \left(1 - e^{-100 \times 10^{-3} \times 25 / 500 \times 10^{-3}} \right) = \frac{1}{5} (1 - e^{-5}) \\ &= \frac{1}{5} (1 - 0.0067) = 0.19864 \end{aligned}$$

Potential difference $= iR = 0.19864 \times 25 = 4.9665 = 4.97 \text{ V}$.

c) $t = 1$ sec

$$\begin{aligned} i &= i_0 (1 - e^{-tR/L}) = \frac{E}{R} (1 - e^{-tR/L}) \\ &= \frac{5}{25} \left(1 - e^{-1 \times 25 / 500 \times 10^{-3}} \right) = \frac{1}{5} (1 - e^{-50}) \\ &= \frac{1}{5} \times 1 = 1/5 \text{ A} \end{aligned}$$

Potential difference $= iR = (1/5 \times 25) \text{ V} = 5 \text{ V}$.

79. $L = 120$ mH $= 0.120$ H

$R = 10 \Omega$, emf $= 6$, $r = 2$

$$i = i_0 (1 - e^{-t/\tau})$$

Now, $dQ = idt$

$$= i_0 (1 - e^{-t/\tau}) dt$$

$$Q = \int dQ = \int_0^1 i_0 (1 - e^{-t/\tau}) dt$$

$$= i_0 \left[\int_0^t dt - \int_0^1 e^{-t/\tau} dt \right] = i_0 \left[t - (-\tau) \int_0^t e^{-t/\tau} dt \right]$$

$$= i_0 [t + \tau(e^{-t/\tau} - 1)] = i_0 [t + \tau e^{-t/\tau}]$$

$$\text{Now, } i_0 = \frac{6}{10 + 2} = \frac{6}{12} = 0.5 \text{ A}$$

$$\tau = \frac{L}{R} = \frac{0.120}{12} = 0.01$$

a) $t = 0.01$ s

$$\begin{aligned} \text{So, } Q &= 0.5[0.01 + 0.01 e^{-0.01/0.01} - 0.01] \\ &= 0.00183 = 1.8 \times 10^{-3} \text{ C} = 1.8 \text{ mC} \end{aligned}$$

b) $t = 20 \text{ ms} = 2 \times 10^{-2} \text{ s}$
 So, $Q = 0.5[0.02 + 0.01 e^{-0.02/0.01} - 0.01]$
 $= 0.005676 = 5.6 \times 10^{-3} \text{ C} = 5.6 \text{ mC}$

c) $t = 100 \text{ ms} = 0.1 \text{ s}$
 So, $Q = 0.5[0.1 + 0.01 e^{-0.1/0.01} - 0.01]$
 $= 0.045 \text{ C} = 45 \text{ mC}$

80. $L = 17 \text{ mH}$, $l = 100 \text{ m}$, $A = 1 \text{ mm}^2 = 1 \times 10^{-6} \text{ m}^2$, $f_{cu} = 1.7 \times 10^{-8} \Omega\text{-m}$

$$R = \frac{f_{cu} l}{A} = \frac{1.7 \times 10^{-8} \times 100}{1 \times 10^{-6}} = 1.7 \Omega$$

$$i = \frac{L}{R} = \frac{0.17 \times 10^{-8}}{1.7} = 10^{-2} \text{ sec} = 10 \text{ m sec.}$$

81. $\tau = L/R = 50 \text{ ms} = 0.05 \text{ s}$

a) $\frac{i_0}{2} = i_0(1 - e^{-t/0.05})$

$$\Rightarrow \frac{1}{2} = 1 - e^{-t/0.05} = e^{-t/0.05} = \frac{1}{2}$$

$$\Rightarrow \ln e^{-t/0.05} = \ln \frac{1}{2}$$

$$\Rightarrow t = 0.05 \times 0.693 = 0.3465 \text{ s} = 34.6 \text{ ms} = 35 \text{ ms.}$$

b) $P = i^2 R = \frac{E^2}{R} (1 - e^{-tR/L})^2$

$$\text{Maximum power} = \frac{E^2}{R}$$

So, $\frac{E^2}{2R} = \frac{E^2}{R} (1 - e^{-tR/L})^2$

$$\Rightarrow 1 - e^{-tR/L} = \frac{1}{\sqrt{2}} = 0.707$$

$$\Rightarrow e^{-tR/L} = 0.293$$

$$\Rightarrow \frac{tR}{L} = -\ln 0.293 = 1.2275$$

$$\Rightarrow t = 50 \times 1.2275 \text{ ms} = 61.2 \text{ ms.}$$

82. Maximum current = $\frac{E}{R}$

In steady state magnetic field energy stored = $\frac{1}{2} L \frac{E^2}{R^2}$

The fourth of steady state energy = $\frac{1}{8} L \frac{E^2}{R^2}$

One half of steady energy = $\frac{1}{4} L \frac{E^2}{R^2}$

$$\frac{1}{8} L \frac{E^2}{R^2} = \frac{1}{2} L \frac{E^2}{R^2} (1 - e^{-tR/L})^2$$

$$\Rightarrow 1 - e^{tR/L} = \frac{1}{2}$$

$$\Rightarrow e^{tR/L} = \frac{1}{2} \Rightarrow t_1 \frac{R}{L} = \ln 2 \Rightarrow t_1 = \tau \ln 2$$

Again $\frac{1}{4} L \frac{E^2}{R^2} = \frac{1}{2} L \frac{E^2}{R^2} (1 - e^{-t_2 R/L})^2$

$$\Rightarrow e^{t_2 R/L} = \frac{\sqrt{2}-1}{\sqrt{2}} = \frac{2-\sqrt{2}}{2}$$

$$\Rightarrow t_2 = \tau \left[\ln \left(\frac{1}{2-\sqrt{2}} \right) + \ln 2 \right]$$

$$\text{So, } t_2 - t_1 = \tau \ln \frac{1}{2-\sqrt{2}}$$

83. $L = 4.0 \text{ H}$, $R = 10 \Omega$, $E = 4 \text{ V}$

a) Time constant $= \tau = \frac{L}{R} = \frac{4}{10} = 0.4 \text{ s}$.

b) $i = 0.63 i_0$

Now, $0.63 i_0 = i_0 (1 - e^{-t/\tau})$

$$\Rightarrow e^{-t/\tau} = 1 - 0.63 = 0.37$$

$$\Rightarrow \ell n e^{-t/\tau} = \ln 0.37$$

$$\Rightarrow -t/\tau = -0.9942$$

$$\Rightarrow t = 0.9942 \times 0.4 = 0.3977 = 0.40 \text{ s}$$

c) $i = i_0 (1 - e^{-t/\tau})$

$$\Rightarrow \frac{4}{10} (1 - e^{-0.4/0.4}) = 0.4 \times 0.6321 = 0.2528 \text{ A}$$

Power delivered $= VI$

$$= 4 \times 0.2528 = 1.01 = 1 \text{ W}$$

d) Power dissipated in Joule heating $= I^2 R$

$$= (0.2528)^2 \times 10 = 0.639 = 0.64 \text{ W}$$

84. $i = i_0 (1 - e^{-t/\tau})$

$$\Rightarrow \mu_0 n i = \mu_0 n i_0 (1 - e^{-t/\tau})$$

$$\Rightarrow B = B_0 (1 - e^{-IR/L})$$

$$\Rightarrow 0.8 B_0 = B_0 (1 - e^{-20 \times 10^{-5} \times R / 2 \times 10^{-3}})$$

$$\Rightarrow 0.8 = (1 - e^{-R/100})$$

$$\Rightarrow e^{-R/100} = 0.2$$

$$\Rightarrow \ell n (e^{-R/100}) = \ell n (0.2)$$

$$\Rightarrow -R/100 = -1.609$$

$$\Rightarrow R = 16.9 = 160 \Omega$$

85. Emf $= E$ LR circuit

a) $dq = idt$

$$= i_0 (1 - e^{-t/\tau}) dt$$

$$= i_0 (1 - e^{-IR/L}) dt \quad [\because \tau = L/R]$$

$$Q = \int_0^t dq = i_0 \left[\int_0^t dt - \int_0^t e^{-tR/L} dt \right]$$

$$= i_0 [t - (-L/R) (e^{-IR/L}) t_0]$$

$$= i_0 [t - L/R (1 - e^{-IR/L})]$$

$$Q = E/R [t - L/R (1 - e^{-IR/L})]$$

b) Similarly as we know work done $= VI = EI$

$$= E i_0 [t - L/R (1 - e^{-IR/L})]$$

$$= \frac{E^2}{R} [t - L/R (1 - e^{-IR/L})]$$

c) $H = \int_0^t i^2 R \cdot dt = \frac{E^2}{R^2} \cdot R \cdot \int_0^t (1 - e^{-tR/L})^2 \cdot dt$

$$= \frac{E^2}{R} \int_0^t (1 + e^{(-2+R)/L} - 2e^{-tR/L}) \cdot dt$$

$$\begin{aligned}
 &= \frac{E^2}{R} \left(t - \frac{L}{2R} e^{-2tR/L} + \frac{L}{R} 2 \cdot e^{-tR/L} \right)_0^t \\
 &= \frac{E^2}{R} \left(t - \frac{L}{2R} e^{-2tR/L} + \frac{2L}{R} \cdot e^{-tR/L} \right) - \left(-\frac{L}{2R} + \frac{2L}{R} \right) \\
 &= \frac{E^2}{R} \left[\left(t - \frac{L}{2R} x^2 + \frac{2L}{R} \cdot x \right) - \frac{3L}{2R} \right] \\
 &= \frac{E^2}{2} \left(t - \frac{L}{2R} (x^2 - 4x + 3) \right)
 \end{aligned}$$

d) $E = \frac{1}{2} Li^2$

$$\begin{aligned}
 &= \frac{1}{2} L \cdot \frac{E^2}{R^2} \cdot (1 - e^{-tR/L})^2 \quad [x = e^{-tR/L}] \\
 &= \frac{LE^2}{2R^2} (1 - x)^2
 \end{aligned}$$

e) Total energy used as heat as stored in magnetic field

$$\begin{aligned}
 &= \frac{E^2}{R} T - \frac{E^2}{R} \cdot \frac{L}{2R} x^2 + \frac{E^2 L}{R r} \cdot 4x^2 - \frac{3L}{2R} \cdot \frac{E^2}{R} + \frac{LE^2}{2R^2} + \frac{LE^2}{2R^2} x^2 - \frac{LE^2}{R^2} x \\
 &= \frac{E^2}{R} t + \frac{E^2 L}{R^2} x - \frac{LE^2}{R^2} \\
 &= \frac{E^2}{R} \left(t - \frac{L}{R} (1 - x) \right)
 \end{aligned}$$

= Energy drawn from battery.
(Hence conservation of energy holds good).

86. $L = 2H, R = 200 \Omega, E = 2 V, t = 10 \text{ ms}$

a) $i = i_0 (1 - e^{-t/\tau})$

$$\begin{aligned}
 &= \frac{2}{200} (1 - e^{-10 \times 10^{-3} \times 200 / 2}) \\
 &= 0.01 (1 - e^{-1}) = 0.01 (1 - 0.3678) \\
 &= 0.01 \times 0.632 = 6.3 \text{ A.}
 \end{aligned}$$

b) Power delivered by the battery

$$\begin{aligned}
 &= VI \\
 &= E i_0 (1 - e^{-t/\tau}) = \frac{E^2}{R} (1 - e^{-t/\tau}) \\
 &= \frac{2 \times 2}{200} (1 - e^{-10 \times 10^{-3} \times 200 / 2}) = 0.02 (1 - e^{-1}) = 0.1264 = 12 \text{ mw.}
 \end{aligned}$$

c) Power dissipated in heating the resistor = $I^2 R$

$$\begin{aligned}
 &= [i_0 (1 - e^{-t/\tau})]^2 R \\
 &= (6.3 \text{ mA})^2 \times 200 = 6.3 \times 6.3 \times 200 \times 10^{-6} \\
 &= 79.38 \times 10^{-4} = 7.938 \times 10^{-3} = 8 \text{ mA.}
 \end{aligned}$$

d) Rate at which energy is stored in the magnetic field $d/dt (1/2 Li^2)$

$$\begin{aligned}
 &= \frac{Li_0^2}{\tau} (e^{-t/\tau} - e^{-2t/\tau}) = \frac{2 \times 10^{-4}}{10^{-2}} (e^{-1} - e^{-2}) \\
 &= 2 \times 10^{-2} (0.2325) = 0.465 \times 10^{-2} \\
 &= 4.6 \times 10^{-3} = 4.6 \text{ mW.}
 \end{aligned}$$

87. $L_A = 1.0 \text{ H}$; $L_B = 2.0 \text{ H}$; $R = 10 \Omega$

a) $t = 0.1 \text{ s}$, $\tau_A = 0.1$, $\tau_B = L/R = 0.2$

$$i_A = i_0(1 - e^{-t/\tau})$$

$$= \frac{2}{10} \left(1 - e^{-\frac{0.1 \times 10}{1}} \right) = 0.2 (1 - e^{-1}) = 0.126424111$$

$$i_B = i_0(1 - e^{-t/\tau})$$

$$= \frac{2}{10} \left(1 - e^{-\frac{0.1 \times 10}{2}} \right) = 0.2 (1 - e^{-1/2}) = 0.078693$$

$$\frac{i_A}{i_B} = \frac{0.12642411}{0.078693} = 1.6$$

b) $t = 200 \text{ ms} = 0.2 \text{ s}$

$$i_A = i_0(1 - e^{-t/\tau})$$

$$= 0.2(1 - e^{-0.2 \times 10 / 1}) = 0.2 \times 0.864664716 = 0.172932943$$

$$i_B = 0.2(1 - e^{-0.2 \times 10 / 2}) = 0.2 \times 0.632120 = 0.126424111$$

$$\frac{i_A}{i_B} = \frac{0.172932943}{0.126424111} = 1.36 = 1.4$$

c) $t = 1 \text{ s}$

$$i_A = 0.2(1 - e^{-1 \times 10 / 1}) = 0.2 \times 0.9999546 = 0.19999092$$

$$i_B = 0.2(1 - e^{-1 \times 10 / 2}) = 0.2 \times 0.99326 = 0.19865241$$

$$\frac{i_A}{i_B} = \frac{0.19999092}{0.19865241} = 1.0$$

88. a) For discharging circuit

$$i = i_0 e^{-t/\tau}$$

$$\Rightarrow 1 = 2 e^{-0.1/\tau}$$

$$\Rightarrow (1/2) = e^{-0.1/\tau}$$

$$\Rightarrow \ln(1/2) = \ln(e^{-0.1/\tau})$$

$$\Rightarrow -0.693 = -0.1/\tau$$

$$\Rightarrow \tau = 0.1/0.693 = 0.144 = 0.14.$$

b) $L = 4 \text{ H}$, $i = L/R$

$$\Rightarrow 0.14 = 4/R$$

$$\Rightarrow R = 4 / 0.14 = 28.57 = 28 \Omega.$$

89.

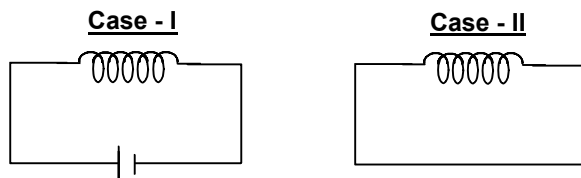

In this case there is no resistor in the circuit.

So, the energy stored due to the inductor before and after removal of battery remains same. i.e.

$$V_1 = V_2 = \frac{1}{2} Li^2$$

So, the current will also remain same.

Thus charge flowing through the conductor is the same.

90. a) The inductor does not work in DC. When the switch is closed the current charges so at first inductor works. But after a long time the current flowing is constant.

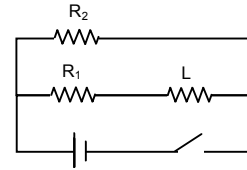

Thus effect of inductance vanishes.

$$i = \frac{E}{R_{\text{net}}} = \frac{E}{\frac{R_1 R_2}{R_1 + R_2}} = \frac{E(R_1 + R_2)}{R_1 R_2}$$

- b) When the switch is opened the resistors are in series.

$$\tau = \frac{L}{R_{\text{net}}} = \frac{L}{R_1 + R_2}$$

91. $i = 1.0 \text{ A}$, $r = 2 \text{ cm}$, $n = 1000 \text{ turn/m}$

$$\text{Magnetic energy stored} = \frac{B^2 V}{2\mu_0}$$

Where $B \rightarrow$ Magnetic field, $V \rightarrow$ Volume of Solenoid.

$$\begin{aligned} &= \frac{\mu_0 n^2 i^2}{2\mu_0} \times \pi r^2 h \\ &= \frac{4\pi \times 10^{-7} \times 10^6 \times 1 \times \pi \times 4 \times 10^{-4} \times 1}{2} \quad [h = 1 \text{ m}] \\ &= 8\pi^2 \times 10^{-5} \\ &= 78.956 \times 10^{-5} = 7.9 \times 10^{-4} \text{ J.} \end{aligned}$$

92. Energy density = $\frac{B^2}{2\mu_0}$

$$\begin{aligned} \text{Total energy stored} &= \frac{B^2 V}{2\mu_0} = \frac{(\mu_0 i / 2r)^2}{2\mu_0} V = \frac{\mu_0 i^2}{4r^2 \times 2} V \\ &= \frac{4\pi \times 10^{-7} \times 4^2 \times 1 \times 10^{-9}}{4 \times (10^{-1})^2 \times 2} = 8\pi \times 10^{-14} \text{ J.} \end{aligned}$$

93. $I = 4.00 \text{ A}$, $V = 1 \text{ mm}^3$,
 $d = 10 \text{ cm} = 0.1 \text{ m}$

$$\bar{B} = \frac{\mu_0 i}{2\pi r}$$

$$\begin{aligned} \text{Now magnetic energy stored} &= \frac{B^2}{2\mu_0} V \\ &= \frac{\mu_0^2 i^2}{4\pi r^2} \times \frac{1}{2\mu_0} \times V = \frac{4\pi \times 10^{-7} \times 16 \times 1 \times 1 \times 10^{-9}}{4 \times 1 \times 10^{-2} \times 2} \\ &= \frac{8}{\pi} \times 10^{-14} \text{ J} \\ &= 2.55 \times 10^{-14} \text{ J} \end{aligned}$$

94. $M = 2.5 \text{ H}$

$$\frac{dl}{dt} = \frac{\ell A}{s}$$

$$E = -\mu \frac{dl}{dt}$$

$$\Rightarrow E = 2.5 \times 1 = 2.5 \text{ V}$$

95. We know

$$\frac{d\phi}{dt} = E = M \times \frac{di}{dt}$$

From the question,

$$\frac{di}{dt} = \frac{d}{dt}(i_0 \sin \omega t) = i_0 \omega \cos \omega t$$

$$\frac{d\phi}{dt} = E = \frac{\mu_0 a i_0 \omega \cos \omega t}{2\pi} \ln[1 + a/b]$$

Now, $E = M \times \frac{di}{dt}$

or, $\frac{\mu_0 a i_0 \omega \cos \omega t}{2\pi} \ln[1 + a/b] = M \times i_0 \omega \cos \omega t$

$$\Rightarrow M = \frac{\mu_0 a}{2\pi} \ln[1 + a/b]$$

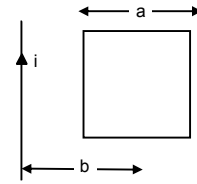

96. emf induced = $\frac{\pi \mu_0 N a^2 a^2 E R V}{2L(a^2 + x^2)^{3/2} (R/Lx + r)^2}$

$$\frac{di}{dt} = \frac{E R V}{L \left(\frac{R x}{L} + r \right)^2} \quad (\text{from question 20})$$

$$\mu = \frac{E}{di/dt} = \frac{N \mu_0 \pi a^2 a^2}{2(a^2 + x^2)^{3/2}}$$

97. Solenoid I :

$$a_1 = 4 \text{ cm}^2 ; n_1 = 4000/0.2 \text{ m} ; \ell_1 = 20 \text{ cm} = 0.20 \text{ m}$$

Solenoid II :

$$a_2 = 8 \text{ cm}^2 ; n_2 = 2000/0.1 \text{ m} ; \ell_2 = 10 \text{ cm} = 0.10 \text{ m}$$

$B = \mu_0 n_2 i$ let the current through outer solenoid be i .

$$\phi = n_1 B \cdot A = n_1 n_2 \mu_0 i \times a_1$$

$$= 2000 \times \frac{2000}{0.1} \times 4\pi \times 10^{-7} \times i \times 4 \times 10^{-4}$$

$$E = \frac{d\phi}{dt} = 64\pi \times 10^{-4} \times \frac{di}{dt}$$

Now $M = \frac{E}{di/dt} = 64\pi \times 10^{-4} \text{ H} = 2 \times 10^{-2} \text{ H}$. [As $E = M di/dt$]

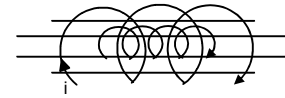

98. a) $B =$ Flux produced due to first coil

$$= \mu_0 n i$$

Flux ϕ linked with the second

$$= \mu_0 n i \times NA = \mu_0 n i N \pi R^2$$

Emf developed

$$= \frac{d\phi}{dt} = \frac{dt}{dt} (\mu_0 n i N \pi R^2)$$

$$= \mu_0 n N \pi R^2 \frac{di}{dt} = \mu_0 n N \pi R^2 i_0 \omega \cos \omega t.$$



CHAPTER – 39 ALTERNATING CURRENT

1. $f = 50 \text{ Hz}$
 $I = I_0 \sin \omega t$
 Peak value $I = \frac{I_0}{\sqrt{2}}$
 $\frac{I_0}{\sqrt{2}} = I_0 \sin \omega t$
 $\Rightarrow \frac{1}{\sqrt{2}} = \sin \omega t = \sin \frac{\pi}{4}$
 $\Rightarrow \frac{\pi}{4} = \omega t$ or, $t = \frac{\pi}{400} = \frac{\pi}{4 \times 2\pi f} = \frac{1}{8f} = \frac{1}{8 \times 50} = 0.0025 \text{ s} = 2.5 \text{ ms}$

2. $E_{\text{rms}} = 220 \text{ V}$
 Frequency = 50 Hz
 (a) $E_{\text{rms}} = \frac{E_0}{\sqrt{2}}$
 $\Rightarrow E_0 = E_{\text{rms}} \sqrt{2} = \sqrt{2} \times 220 = 1.414 \times 220 = 311.08 \text{ V} = 311 \text{ V}$
 (b) Time taken for the current to reach the peak value = Time taken to reach the 0 value from r.m.s
 $I = \frac{I_0}{\sqrt{2}} \Rightarrow \frac{I_0}{\sqrt{2}} = I_0 \sin \omega t$
 $\Rightarrow \omega t = \frac{\pi}{4}$
 $\Rightarrow t = \frac{\pi}{4\omega} = \frac{\pi}{4 \times 2\pi f} = \frac{\pi}{8\pi 50} = \frac{1}{400} = 2.5 \text{ ms}$

3. $P = 60 \text{ W}$ $V = 220 \text{ V} = E$
 $R = \frac{V^2}{P} = \frac{220 \times 220}{60} = 806.67$
 $\varepsilon_0 = \sqrt{2} E = 1.414 \times 220 = 311.08$
 $I_0 = \frac{\varepsilon_0}{R} = \frac{806.67}{311.08} = 0.385 \approx 0.39 \text{ A}$

4. $E = 12 \text{ volts}$
 $i^2 R t = i_{\text{rms}}^2 R T$
 $\Rightarrow \frac{E^2}{R^2} = \frac{E_{\text{rms}}^2}{R^2} \Rightarrow E^2 = \frac{E_0^2}{2}$
 $\Rightarrow E_0^2 = 2E^2 \Rightarrow E_0^2 = 2 \times 12^2 = 2 \times 144$
 $\Rightarrow E_0 = \sqrt{2 \times 144} = 16.97 \approx 17 \text{ V}$

5. $P_0 = 80 \text{ W}$ (given)
 $P_{\text{rms}} = \frac{P_0}{2} = 40 \text{ W}$
 Energy consumed = $P \times t = 40 \times 100 = 4000 \text{ J} = 4.0 \text{ KJ}$

6. $E = 3 \times 10^6 \text{ V/m}$, $A = 20 \text{ cm}^2$, $d = 0.1 \text{ mm}$
 Potential diff. across the capacitor = $Ed = 3 \times 10^6 \times 0.1 \times 10^{-3} = 300 \text{ V}$
 Max. rms Voltage = $\frac{V}{\sqrt{2}} = \frac{300}{\sqrt{2}} = 212 \text{ V}$

7. $i = i_0 e^{-t/\tau}$

$$\bar{i}^2 = \frac{1}{\tau} \int_0^{\tau} i_0^2 e^{-2t/\tau} dt = \frac{i_0^2}{\tau} \int_0^{\tau} e^{-2t/\tau} dt = \frac{i_0^2}{\tau} \times \left[\frac{\tau}{2} e^{-2t/\tau} \right]_0^{\tau} = -\frac{i_0^2}{\tau} \times \frac{\tau}{2} \times [e^{-2} - 1]$$

$$\sqrt{\bar{i}^2} = \sqrt{-\frac{i_0^2}{2} (e^{-2} - 1)} = \frac{i_0}{e} \sqrt{\frac{e^2 - 1}{2}}$$

8. $C = 10 \mu\text{F} = 10 \times 10^{-6} \text{ F} = 10^{-5} \text{ F}$

$E = (10 \text{ V}) \sin \omega t$

a) $I = \frac{E_0}{X_C} = \frac{E_0}{\left(\frac{1}{\omega C}\right)} = \frac{10}{\left(\frac{1}{10 \times 10^{-5}}\right)} = 1 \times 10^{-3} \text{ A}$

b) $\omega = 100 \text{ s}^{-1}$

$$I = \frac{E_0}{\left(\frac{1}{\omega C}\right)} = \frac{10}{\left(\frac{1}{100 \times 10^{-5}}\right)} = 1 \times 10^{-2} \text{ A} = 0.01 \text{ A}$$

c) $\omega = 500 \text{ s}^{-1}$

$$I = \frac{E_0}{\left(\frac{1}{\omega C}\right)} = \frac{10}{\left(\frac{1}{500 \times 10^{-5}}\right)} = 5 \times 10^{-2} \text{ A} = 0.05 \text{ A}$$

d) $\omega = 1000 \text{ s}^{-1}$

$$I = \frac{E_0}{\left(\frac{1}{\omega C}\right)} = \frac{10}{\left(\frac{1}{1000 \times 10^{-5}}\right)} = 1 \times 10^{-1} \text{ A} = 0.1 \text{ A}$$

9. Inductance = 5.0 mH = 0.005 H

a) $\omega = 100 \text{ s}^{-1}$

$$X_L = \omega L = 100 \times \frac{5}{1000} = 0.5 \Omega$$

$$i = \frac{\varepsilon_0}{X_L} = \frac{10}{0.5} = 20 \text{ A}$$

b) $\omega = 500 \text{ s}^{-1}$

$$X_L = \omega L = 500 \times \frac{5}{1000} = 2.5 \Omega$$

$$i = \frac{\varepsilon_0}{X_L} = \frac{10}{2.5} = 4 \text{ A}$$

c) $\omega = 1000 \text{ s}^{-1}$

$$X_L = \omega L = 1000 \times \frac{5}{1000} = 5 \Omega$$

$$i = \frac{\varepsilon_0}{X_L} = \frac{10}{5} = 2 \text{ A}$$

10. $R = 10 \Omega$, $L = 0.4 \text{ Henry}$

$E = 6.5 \text{ V}$, $f = \frac{30}{\pi} \text{ Hz}$

$$Z = \sqrt{R^2 + X_L^2} = \sqrt{R^2 + (2\pi fL)^2}$$

Power = $V_{\text{rms}} I_{\text{rms}} \cos \phi$

$$= 6.5 \times \frac{6.5}{Z} \times \frac{R}{Z} = \frac{6.5 \times 6.5 \times 10}{\left[\sqrt{R^2 + (2\pi fL)^2}\right]^2} = \frac{6.5 \times 6.5 \times 10}{10^2 + \left(2\pi \times \frac{30}{\pi} \times 0.4\right)^2} = \frac{6.5 \times 6.5 \times 10}{100 + 576} = 0.625 = \frac{5}{8} \omega$$

11. $H = \frac{V^2}{R} T$, $E_0 = 12 \text{ V}$, $\omega = 250 \pi$, $R = 100 \Omega$

$$H = \int_0^H dH = \int \frac{E_0^2 \sin^2 \omega t}{R} dt = \frac{144}{100} \int \sin^2 \omega t dt = 1.44 \int \left(\frac{1 - \cos 2\omega t}{2} \right) dt$$

$$= \frac{1.44}{2} \left[\int_0^{10^{-3}} dt - \int_0^{10^{-3}} \cos 2\omega t dt \right] = 0.72 \left[10^{-3} - \left(\frac{\sin 2\omega t}{2\omega} \right)_0^{10^{-3}} \right]$$

$$= 0.72 \left[\frac{1}{1000} - \frac{1}{500\pi} \right] = \frac{(\pi - 2)}{1000\pi} \times 0.72 = 0.0002614 = 2.61 \times 10^{-4} \text{ J}$$

12. $R = 300 \Omega$, $C = 25 \mu\text{F} = 25 \times 10^{-6} \text{ F}$, $\varepsilon_0 = 50 \text{ V}$, $f = 50 \text{ Hz}$

$$X_c = \frac{1}{\omega C} = \frac{1}{\frac{50}{\pi} \times 2\pi \times 25 \times 10^{-6}} = \frac{10^4}{25}$$

$$Z = \sqrt{R^2 + X_c^2} = \sqrt{(300)^2 + \left(\frac{10^4}{25} \right)^2} = \sqrt{(300)^2 + (400)^2} = 500$$

(a) Peak current = $\frac{E_0}{Z} = \frac{50}{500} = 0.1 \text{ A}$

(b) Average Power dissipated, = $E_{\text{rms}} I_{\text{rms}} \cos \phi$

$$= \frac{E_0}{\sqrt{2}} \times \frac{E_0}{\sqrt{2Z}} \times \frac{R}{Z} = \frac{E_0^2}{2Z^2} = \frac{50 \times 50 \times 300}{2 \times 500 \times 500} = \frac{3}{2} = 1.5 \text{ W}$$

13. Power = 55 W, Voltage = 110 V, Resistance = $\frac{V^2}{P} = \frac{110 \times 110}{55} = 220 \Omega$

frequency (f) = 50 Hz, $\omega = 2\pi f = 2\pi \times 50 = 100 \pi$

Current in the circuit = $\frac{V}{Z} = \frac{V}{\sqrt{R^2 + (\omega L)^2}}$

Voltage drop across the resistor = $ir = \frac{VR}{\sqrt{R^2 + (\omega L)^2}}$

$$= \frac{220 \times 220}{\sqrt{(220)^2 + (100\pi L)^2}} = 110$$

$$\Rightarrow 220 \times 2 = \sqrt{(220)^2 + (100\pi L)^2} \Rightarrow (220)^2 + (100\pi L)^2 = (440)^2$$

$$\Rightarrow 48400 + 10^4 \pi^2 L^2 = 193600 \Rightarrow 10^4 \pi^2 L^2 = 193600 - 48400$$

$$\Rightarrow L^2 = \frac{142500}{\pi^2 \times 10^4} = 1.4726 \Rightarrow L = 1.2135 \approx 1.2 \text{ Hz}$$

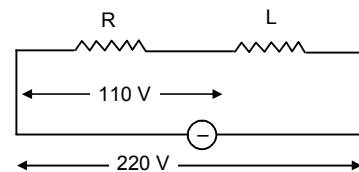

14. $R = 300 \Omega$, $C = 20 \mu\text{F} = 20 \times 10^{-6} \text{ F}$

$L = 1 \text{ Henry}$, $E = 50 \text{ V}$, $V = \frac{50}{\pi} \text{ Hz}$

(a) $I_0 = \frac{E_0}{Z}$,

$$Z = \sqrt{R^2 + (X_c - X_L)^2} = \sqrt{(300)^2 + \left(\frac{1}{2\pi f C} - 2\pi f L \right)^2}$$

$$= \sqrt{(300)^2 + \left(\frac{1}{2\pi \times \frac{50}{\pi} \times 20 \times 10^{-6}} - 2\pi \times \frac{50}{\pi} \times 1 \right)^2} = \sqrt{(300)^2 + \left(\frac{10^4}{20} - 100 \right)^2} = 500$$

$$I_0 = \frac{E_0}{Z} = \frac{50}{500} = 0.1 \text{ A}$$

- (b) Potential across the capacitor = $i_0 \times X_c = 0.1 \times 500 = 50 \text{ V}$
 Potential difference across the resistor = $i_0 \times R = 0.1 \times 300 = 30 \text{ V}$
 Potential difference across the inductor = $i_0 \times X_L = 0.1 \times 100 = 10 \text{ V}$
 Rms. potential = 50 V
 Net sum of all potential drops = 50 V + 30 V + 10 V = 90 V
 Sum of potential drops > R.M.S potential applied.

15. $R = 300 \Omega$

$C = 20 \mu\text{F} = 20 \times 10^{-6} \text{ F}$

$L = 1\text{H}, \quad Z = 500 \text{ (from 14)}$

$\epsilon_0 = 50 \text{ V}, \quad I_0 = \frac{E_0}{Z} = \frac{50}{500} = 0.1 \text{ A}$

Electric Energy stored in Capacitor = $(1/2) CV^2 = (1/2) \times 20 \times 10^{-6} \times 50 \times 50 = 25 \times 10^{-3} \text{ J} = 25 \text{ mJ}$

Magnetic field energy stored in the coil = $(1/2) L I_0^2 = (1/2) \times 1 \times (0.1)^2 = 5 \times 10^{-3} \text{ J} = 5 \text{ mJ}$

16. (a) For current to be maximum in a circuit

$X_L = X_C \quad \text{(Resonant Condition)}$

$\Rightarrow \omega L = \frac{1}{\omega C}$

$\Rightarrow \omega^2 = \frac{1}{LC} = \frac{1}{2 \times 18 \times 10^{-6}} = \frac{10^6}{36}$

$\Rightarrow \omega = \frac{10^3}{6} \Rightarrow 2\pi f = \frac{10^3}{6}$

$\Rightarrow f = \frac{1000}{6 \times 2\pi} = 26.537 \text{ Hz} \approx 27 \text{ Hz}$

(b) Maximum Current = $\frac{E}{R}$ (in resonance and)

$= \frac{20}{10 \times 10^3} = \frac{2}{10^3} \text{ A} = 2 \text{ mA}$

17. $E_{\text{rms}} = 24 \text{ V}$

$r = 4 \Omega, \quad I_{\text{rms}} = 6 \text{ A}$

$R = \frac{E}{I} = \frac{24}{6} = 4 \Omega$

Internal Resistance = 4 Ω

Hence net resistance = 4 + 4 = 8 Ω

$\therefore \text{Current} = \frac{12}{8} = 1.5 \text{ A}$

18. $V_1 = 10 \times 10^{-3} \text{ V}$

$R = 1 \times 10^3 \Omega$

$C = 10 \times 10^{-9} \text{ F}$

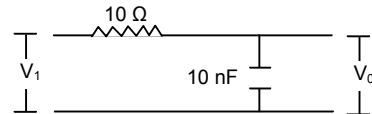

(a) $X_c = \frac{1}{\omega C} = \frac{1}{2\pi f C} = \frac{1}{2\pi \times 10 \times 10^3 \times 10 \times 10^{-9}} = \frac{1}{2\pi \times 10^{-4}} = \frac{10^4}{2\pi} = \frac{5000}{\pi}$

$Z = \sqrt{R^2 + X_c^2} = \sqrt{(1 \times 10^3)^2 + \left(\frac{5000}{\pi}\right)^2} = \sqrt{10^6 + \left(\frac{5000}{\pi}\right)^2}$

$I_0 = \frac{E_0}{Z} = \frac{V_1}{Z} = \frac{10 \times 10^{-3}}{\sqrt{10^6 + \left(\frac{5000}{\pi}\right)^2}}$

$$(b) X_c = \frac{1}{WC} = \frac{1}{2\pi fC} = \frac{1}{2\pi \times 10^5 \times 10 \times 10^{-9}} = \frac{1}{2\pi \times 10^{-3}} = \frac{10^3}{2\pi} = \frac{500}{\pi}$$

$$Z = \sqrt{R^2 + X_c^2} = \sqrt{(10^3)^2 + \left(\frac{500}{\pi}\right)^2} = \sqrt{10^6 + \left(\frac{500}{\pi}\right)^2}$$

$$I_0 = \frac{E_0}{Z} = \frac{V_1}{Z} = \frac{10 \times 10^{-3}}{\sqrt{10^6 + \left(\frac{500}{\pi}\right)^2}}$$

$$V_0 = I_0 X_c = \frac{10 \times 10^{-3}}{\sqrt{10^6 + \left(\frac{500}{\pi}\right)^2}} \times \frac{500}{\pi} = 1.6124 \text{ V} \approx 1.6 \text{ mV}$$

$$(c) f = 1 \text{ MHz} = 10^6 \text{ Hz}$$

$$X_c = \frac{1}{WC} = \frac{1}{2\pi fC} = \frac{1}{2\pi \times 10^6 \times 10 \times 10^{-9}} = \frac{1}{2\pi \times 10^{-2}} = \frac{10^2}{2\pi} = \frac{50}{\pi}$$

$$Z = \sqrt{R^2 + X_c^2} = \sqrt{(10^3)^2 + \left(\frac{50}{\pi}\right)^2} = \sqrt{10^6 + \left(\frac{50}{\pi}\right)^2}$$

$$I_0 = \frac{E_0}{Z} = \frac{V_1}{Z} = \frac{10 \times 10^{-3}}{\sqrt{10^6 + \left(\frac{50}{\pi}\right)^2}}$$

$$V_0 = I_0 X_c = \frac{10 \times 10^{-3}}{\sqrt{10^6 + \left(\frac{50}{\pi}\right)^2}} \times \frac{50}{\pi} \approx 0.16 \text{ mV}$$

$$(d) f = 10 \text{ MHz} = 10^7 \text{ Hz}$$

$$X_c = \frac{1}{WC} = \frac{1}{2\pi fC} = \frac{1}{2\pi \times 10^7 \times 10 \times 10^{-9}} = \frac{1}{2\pi \times 10^{-1}} = \frac{10}{2\pi} = \frac{5}{\pi}$$

$$Z = \sqrt{R^2 + X_c^2} = \sqrt{(10^3)^2 + \left(\frac{5}{\pi}\right)^2} = \sqrt{10^6 + \left(\frac{5}{\pi}\right)^2}$$

$$I_0 = \frac{E_0}{Z} = \frac{V_1}{Z} = \frac{10 \times 10^{-3}}{\sqrt{10^6 + \left(\frac{5}{\pi}\right)^2}}$$

$$V_0 = I_0 X_c = \frac{10 \times 10^{-3}}{\sqrt{10^6 + \left(\frac{5}{\pi}\right)^2}} \times \frac{5}{\pi} \approx 16 \mu\text{V}$$

19. Transformer works upon the principle of induction which is only possible in case of AC.

Hence when DC is supplied to it, the primary coil blocks the Current supplied to it and hence induced current supplied to it and hence induced Current in the secondary coil is zero.

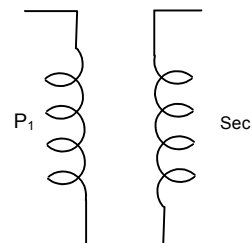

◆ ◆ ◆ ◆ ◆

ELECTROMAGNETIC WAVES CHAPTER - 40

$$1. \quad \frac{\epsilon_0 d\phi_E}{dt} = \frac{\epsilon_0 EA}{dt 4\pi \epsilon_0 r^2}$$

$$= \frac{M^{-1}L^{-3}T^4A^2}{M^{-1}L^{-3}A^2} \times \frac{A^1T^1}{L^2} \times \frac{L^2}{T} = A^1$$

= (Current) (proved).

$$2. \quad E = \frac{Kq}{x^2}, \text{ [from coulomb's law]}$$

$$\phi_E = EA = \frac{KqA}{x^2}$$

$$i_d = \epsilon_0 \frac{d\phi_E}{dt} = \epsilon_0 \frac{d}{dt} \left(\frac{KqA}{x^2} \right) = \epsilon_0 KqA \frac{d}{dt} x^{-2}$$

$$= \epsilon_0 \times \frac{1}{4\pi \epsilon_0} \times q \times A \times -2 \times x^{-3} \times \frac{dx}{dt} = \frac{qAv}{2\pi x^3}$$

$$3. \quad E = \frac{Q}{\epsilon_0 A} \text{ (Electric field)}$$

$$\phi = E.A. = \frac{Q}{\epsilon_0 A} \frac{A}{2} = \frac{Q}{\epsilon_0 2}$$

$$i_0 = \epsilon_0 \frac{d\phi_E}{dt} = \epsilon_0 \frac{d}{dt} \left(\frac{Q}{\epsilon_0 2} \right) = \frac{1}{2} \left(\frac{dQ}{dt} \right)$$

$$= \frac{1}{2} \frac{d}{dt} (ECe^{-t/RC}) = \frac{1}{2} EC - \frac{1}{RC} e^{-t/RC} = \frac{-E}{2R} e^{-\frac{t}{RC}}$$

$$4. \quad E = \frac{Q}{\epsilon_0 A} \text{ (Electric field)}$$

$$\phi = E.A. = \frac{Q}{\epsilon_0 A} \frac{A}{2} = \frac{Q}{\epsilon_0 2}$$

$$i_0 = \epsilon_0 \frac{d\phi_E}{dt} = \epsilon_0 \frac{d}{dt} \left(\frac{Q}{\epsilon_0 2} \right) = \frac{1}{2} \left(\frac{dQ}{dt} \right)$$

$$5. \quad B = \mu_0 H$$

$$\Rightarrow H = \frac{B}{\mu_0}$$

$$\frac{E_0}{H_0} = \frac{B_0 / (\mu_0 \epsilon_0 C)}{B_0 / \mu_0} = \frac{1}{\epsilon_0 C}$$

$$= \frac{1}{8.85 \times 10^{-12} \times 3 \times 10^8} = 376.6 \Omega = 377 \Omega.$$

$$\text{Dimension } \frac{1}{\epsilon_0 C} = \frac{1}{[LT^{-1}][M^{-1}L^{-3}T^4A^2]} = \frac{1}{M^{-1}L^{-2}T^3A^2} = M^1L^2T^{-3}A^{-2} = [R].$$

$$6. \quad E_0 = 810 \text{ V/m}, B_0 = ?$$

We know, $B_0 = \mu_0 \epsilon_0 C E_0$

Putting the values,

$$B_0 = 4\pi \times 10^{-7} \times 8.85 \times 10^{-12} \times 3 \times 10^8 \times 810$$

$$= 27010.9 \times 10^{-10} = 2.7 \times 10^{-6} \text{ T} = 2.7 \mu\text{T}.$$

7. $B = (200 \mu\text{T}) \sin [(4 \times 10^{15} \text{ s}^{-1}) (t - x/c)]$

a) $B_0 = 200 \mu\text{T}$

$$E_0 = c \times B_0 = 200 \times 10^{-6} \times 3 \times 10^8 = 6 \times 10^4$$

b) Average energy density = $\frac{1}{2\mu_0} B_0^2 = \frac{(200 \times 10^{-6})^2}{2 \times 4\pi \times 10^{-7}} = \frac{4 \times 10^{-8}}{8\pi \times 10^{-7}} = \frac{1}{20\pi} = 0.0159 = 0.016$.

8. $I = 2.5 \times 10^{14} \text{ W/m}^2$

We know, $I = \frac{1}{2} \epsilon_0 E_0^2 c$

$$\Rightarrow E_0^2 = \frac{2I}{\epsilon_0 c} \quad \text{or} \quad E_0 = \sqrt{\frac{2I}{\epsilon_0 c}}$$

$$E_0 = \sqrt{\frac{2 \times 2.5 \times 10^{14}}{8.85 \times 10^{-12} \times 3 \times 10^8}} = 0.4339 \times 10^9 = 4.33 \times 10^8 \text{ N/c.}$$

$$B_0 = \mu_0 \epsilon_0 c E_0$$

$$= 4 \times 3.14 \times 10^{-7} \times 8.854 \times 10^{-12} \times 3 \times 10^8 \times 4.33 \times 10^8 = 1.44 \text{ T.}$$

9. Intensity of wave = $\frac{1}{2} \epsilon_0 E_0^2 c$

$$\epsilon_0 = 8.85 \times 10^{-12}; E_0 = ?; c = 3 \times 10^8, I = 1380 \text{ W/m}^2$$

$$1380 = 1/2 \times 8.85 \times 10^{-12} \times E_0^2 \times 3 \times 10^8$$

$$\Rightarrow E_0^2 = \frac{2 \times 1380}{8.85 \times 3 \times 10^{-4}} = 103.95 \times 10^4$$

$$\Rightarrow E_0 = 10.195 \times 10^2 = 1.02 \times 10^3$$

$$E_0 = B_0 c$$

$$\Rightarrow B_0 = E_0/c = \frac{1.02 \times 10^3}{3 \times 10^8} = 3.398 \times 10^{-5} = 3.4 \times 10^{-5} \text{ T.}$$



ELECTRIC CURRENT THROUGH GASES CHAPTER 41

1. Let the two particles have charge 'q'
 Mass of electron $m_e = 9.1 \times 10^{-31}$ kg
 Mass of proton $m_p = 1.67 \times 10^{-27}$ kg
 Electric field be E
 Force experienced by Electron = qE
 accln. = qE/m_e
 For time dt

$$S_e = \frac{1}{2} \times \frac{qE}{m_e} \times dt^2 \quad \dots(1)$$

For the positive ion,

$$\text{accln.} = \frac{qE}{4 \times m_p}$$

$$S_p = \frac{1}{2} \times \frac{qE}{4 \times m_p} \times dt^2 \quad \dots(2)$$

$$\frac{S_e}{S_p} = \frac{4m_p}{m_e} = 7340.6$$

2. $E = 5 \text{ Kv/m} = 5 \times 10^3 \text{ v/m}$; $t = 1 \text{ } \mu\text{s} = 1 \times 10^{-6} \text{ s}$
 $F = qE = 1.6 \times 10^{-9} \times 5 \times 10^3$

$$a = \frac{qE}{m} = \frac{1.6 \times 5 \times 10^{-16}}{9.1 \times 10^{-31}}$$

a) $S = \text{distance travelled}$

$$= \frac{1}{2} at^2 = 439.56 \text{ m} = 440 \text{ m}$$

b) $d = 1 \text{ mm} = 1 \times 10^{-3} \text{ m}$

$$1 \times 10^{-3} = \frac{1}{2} \times \frac{1.6 \times 5}{9.1} 10^5 \times t^2$$

$$\Rightarrow t^2 = \frac{9.1}{0.8 \times 5} \times 10^{-18} \Rightarrow t = 1.508 \times 10^{-9} \text{ sec} \Rightarrow 1.5 \text{ ns.}$$

3. Let the mean free path be 'L' and pressure be 'P'
 $L \propto 1/p$ for $L = \text{half of the tube length}$, $P = 0.02 \text{ mm of Hg}$
 As 'P' becomes half, 'L' doubles, that is the whole tube is filled with Crook's dark space.
 Hence the required pressure = $0.02/2 = 0.01 \text{ m of Hg}$.

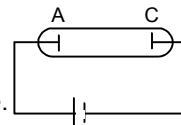

4. $V = f(Pd)$
 $v_s = P_s d_s$
 $v_L = P_l d_l$
 $\Rightarrow \frac{V_s}{V_l} = \frac{P_s}{P_l} \times \frac{d_s}{d_l} \Rightarrow \frac{100}{100} = \frac{10}{20} \times \frac{1\text{mm}}{x}$
 $\Rightarrow x = 1 \text{ mm} / 2 = 0.5 \text{ mm}$

5. $i = ne$ or $n = i/e$
 'e' is same in all cases.
 We know,

$$i = AS^2 e^{-\phi/RT} \quad \phi = 4.52 \text{ eV}, K = 1.38 \times 10^{-23} \text{ J/k}$$

$$n(1000) = AS \times (1000)^2 \times e^{-4.52 \times 1.6 \times 10^{-19} / 1.38 \times 10^{-23} \times 1000} \\ \Rightarrow 1.7396 \times 10^{-17}$$

a) $T = 300 \text{ K}$

$$\frac{n(T)}{n(1000\text{K})} = \frac{AS \times (300)^2 \times e^{-4.52 \times 1.6 \times 10^{-19} / 1.38 \times 10^{-23} \times 300}}{AS \times 1.7396 \times 10^{-17}} = 7.05 \times 10^{-55}$$

b) $T = 2000 \text{ K}$

$$\frac{n(T)}{n(1000\text{K})} = \frac{AS \times (2000)^2 \times e^{-4.52 \times 1.6 \times 10^{-19} / 1.38 \times 10^{-23} \times 2000}}{AS \times 1.7396 \times 10^{-17}} = 9.59 \times 10^{11}$$

c) $T = 3000 \text{ K}$

$$\frac{n(T)}{n(1000\text{K})} = \frac{AS \times (3000)^2 \times e^{-4.52 \times 1.6 \times 10^{-19} / 1.38 \times 10^{-23} \times 3000}}{AS \times 1.7396 \times 10^{-17}} = 1.340 \times 10^{16}$$

6. $i = AS^2 e^{-\phi/KT}$

$i_1 = i$	$i_2 = 100 \text{ mA}$
$A_1 = 60 \times 10^4$	$A_2 = 3 \times 10^4$
$S_1 = S$	$S_2 = S$
$T_1 = 2000$	$T_2 = 2000$
$\phi_1 = 4.5 \text{ eV}$	$\phi_2 = 2.6 \text{ eV}$
$K = 1.38 \times 10^{-23} \text{ J/k}$	

$$i = (60 \times 10^4) (S) \times (2000)^2 e^{\frac{-4.5 \times 1.6 \times 10^{-19}}{1.38 \times 10^{-23} \times 2000}}$$

$$100 = (3 \times 10^4) (S) \times (2000)^2 e^{\frac{-2.6 \times 1.6 \times 10^{-19}}{1.38 \times 10^{-23} \times 2000}}$$

Dividing the equation

$$\frac{i}{100} = e^{\left[\frac{-4.5 \times 1.6 \times 10^{-19}}{1.38 \times 2} - \left(\frac{-2.6 \times 1.6 \times 10^{-19}}{1.38 \times 20} \right) \right]}$$

$$\Rightarrow \frac{i}{100} = 20 \times e^{-11.014} \Rightarrow \frac{i}{100} = 20 \times 0.000016$$

$$\Rightarrow i = 20 \times 0.0016 = 0.0329 \text{ mA} = 33 \mu\text{A}$$

7. Pure tungsten

$$\phi = 4.5 \text{ eV}$$

$$A = 60 \times 10^4 \text{ A/m}^2 - \text{k}^2$$

$$i = AS^2 e^{-\phi/KT}$$

$$i_{\text{Thoriated Tungsten}} = 5000 i_{\text{Tungsten}}$$

$$\text{So, } 5000 \times S \times 60 \times 10^4 \times T^2 \times e^{\frac{-4.5 \times 1.6 \times 10^{-19}}{1.38 \times T \times 10^{-23}}}$$

$$\Rightarrow S \times 3 \times 10^4 \times T^2 \times e^{\frac{-2.65 \times 1.6 \times 10^{-19}}{1.38 \times T \times 10^{-23}}}$$

$$\Rightarrow 3 \times 10^8 \times e^{\frac{-4.5 \times 1.6 \times 10^{-19}}{1.38 \times T \times 10^{-23}}} = e^{\frac{-2.65 \times 1.6 \times 10^{-19}}{1.38 \times T \times 10^{-23}}} \times 3 \times 10^4$$

Taking 'ln'

$$\Rightarrow 9.21 T = 220.29$$

$$\Rightarrow T = 22029 / 9.21 = 2391.856 \text{ K}$$

Thoriated tungsten

$$\phi = 2.6 \text{ eV}$$

$$A = 3 \times 10^4 \text{ A/m}^2 - \text{k}^2$$

8. $i = AST^2 e^{-\phi/KT}$

$i' = AST'^2 e^{-\phi/KT'}$

$$\frac{i}{i'} = \frac{T^2 e^{-\phi/KT}}{T'^2 e^{-\phi/KT'}}$$

$$\Rightarrow \frac{i}{i'} = \left(\frac{T}{T'}\right)^2 e^{-\phi/KT + \phi/KT'} = \left(\frac{T}{T'}\right)^2 e^{\phi/KT' - \phi/KT}$$

$$= \frac{i}{i'} = \left(\frac{2000}{2010}\right)^2 e^{\frac{4.5 \times 1.6 \times 10^{-19}}{1.38 \times 10^{-23}} \left(\frac{1}{2010} - \frac{1}{2000}\right)} = 0.8690$$

$$\Rightarrow \frac{i}{i'} = \frac{1}{0.8699} = 1.1495 = 1.14$$

9. $A = 60 \times 10^4 \text{ A/m}^2 - \text{k}^2$

$\phi = 4.5 \text{ eV}$

$\sigma = 6 \times 10^{-8} \text{ W/m}^2 - \text{k}^4$

$S = 2 \times 10^{-5} \text{ m}^2$

$K = 1.38 \times 10^{-23} \text{ J/K}$

$H = 24 \text{ W}$

The Cathode acts as a black body, i.e. emissivity = 1

$\therefore E = \sigma A T^4$ (A is area)

$$\Rightarrow T^4 = \frac{E}{\sigma A} = \frac{24}{6 \times 10^{-8} \times 2 \times 10^{-5}} = 2 \times 10^{13} \text{ K} = 20 \times 10^{12} \text{ K}$$

$$\Rightarrow T = 2.1147 \times 10^3 = 2114.7 \text{ K}$$

Now, $i = AST^2 e^{-\phi/KT}$

$$= 6 \times 10^5 \times 2 \times 10^{-5} \times (2114.7)^2 \times e^{\frac{-4.5 \times 1.6 \times 10^{-19}}{1.38 \times 10^{-23} \times 2114.7}}$$

$$= 1.03456 \times 10^{-3} \text{ A} = 1 \text{ mA}$$

10. $i_p = CV_p^{3/2}$... (1)

$$\Rightarrow di_p = C \cdot \frac{3}{2} V_p^{(3/2)-1} dv_p$$

$$\Rightarrow \frac{di_p}{dv_p} = \frac{3}{2} CV_p^{1/2}$$
 ... (2)

Dividing (2) and (1)

$$\frac{i}{i_p} \frac{di_p}{dv_p} = \frac{3/2 CV_p^{1/2}}{CV_p^{3/2}}$$

$$\Rightarrow \frac{1}{i_p} \frac{di_p}{dv_p} = \frac{3}{2V}$$

$$\Rightarrow \frac{dv_p}{di_p} = \frac{2V}{3i_p}$$

$$\Rightarrow R = \frac{2V}{3i_p} = \frac{2 \times 60}{3 \times 10 \times 10^{-3}} = 4 \times 10^3 = 4 \text{ k}\Omega$$

11. For plate current 20 mA, we find the voltage 50 V or 60 V.

Hence it acts as the saturation current. Therefore for the same temperature, the plate current is 20 mA for all other values of voltage.

Hence the required answer is 20 mA.

12. $P = 1 \text{ W}$, $p = ?$

$V_p = 36 \text{ V}$, $V_p = 49 \text{ V}$, $P = I_p V_p$

$$\Rightarrow I_p = \frac{P}{V_p} = \frac{1}{36}$$

$$I_p \propto (V_p)^{3/2}$$

$$I'_p \propto (V'_p)^{3/2}$$

$$\Rightarrow \frac{I_p}{I'_p} = \frac{(V_p)^{3/2}}{V'_p}$$

$$\Rightarrow \frac{1/36}{I'_p} = \left(\frac{36}{49}\right)^{3/2}$$

$$\Rightarrow \frac{1}{36 I'_p} = \frac{36}{49} \times \frac{6}{7} \Rightarrow I'_p = 0.4411$$

$$P' = V'_p I'_p = 49 \times 0.4411 = 2.1613 \text{ W} = 2.2 \text{ W}$$

13. Amplification factor for triode value

$$= \mu = \frac{\text{Change in Plate Voltage}}{\text{Change in Grid Voltage}} = \frac{\delta V_p}{\delta V_g}$$

$$= \frac{250 - 225}{2.5 - 0.5} = \frac{25}{2} = 12.5 \quad [\because \delta V_p = 250 - 225, \delta V_g = 2.5 - 0.5]$$

14. $r_p = 2 \text{ K}\Omega = 2 \times 10^3 \Omega$

$$g_m = 2 \text{ milli mho} = 2 \times 10^{-3} \text{ mho}$$

$$\mu = r_p \times g_m = 2 \times 10^3 \times 2 \times 10^{-3} = 4 \text{ Amplification factor is 4.}$$

15. Dynamic Plate Resistance $r_p = 10 \text{ K}\Omega = 10^4 \Omega$

$$\delta I_p = ?$$

$$\delta V_p = 220 - 200 = 20 \text{ V}$$

$$\delta I_p = (\delta V_p / r_p) / V_g = \text{constant.}$$

$$= 20/10^4 = 0.002 \text{ A} = 2 \text{ mA}$$

16. $r_p = \left(\frac{\delta V_p}{\delta I_p}\right)$ at constant V_g

Consider the two points on $V_g = -6$ line

$$r_p = \frac{(240 - 160)\text{V}}{(13 - 3) \times 10^{-3} \text{A}} = \frac{80}{10} \times 10^3 \Omega = 8 \text{K}\Omega$$

$$g_m = \left(\frac{\delta I_p}{\delta V_g}\right) V_p = \text{constant}$$

Considering the points on 200 V line,

$$g_m = \frac{(13 - 3) \times 10^{-3}}{[(-4) + (-8)]} \text{A} = \frac{10 \times 10^{-3}}{4} = 2.5 \text{ milli mho}$$

$$\mu = r_p \times g_m$$

$$= 8 \times 10^3 \Omega \times 2.5 \times 10^{-3} \Omega^{-1} = 8 \times 1.5 = 20$$

17. a) $r_p = 8 \text{ K}\Omega = 8000 \Omega$

$$\delta V_p = 48 \text{ V} \quad \delta I_p = ?$$

$$\delta I_p = (\delta V_p / r_p) / V_g = \text{constant.}$$

$$\text{So, } \delta I_p = 48 / 8000 = 0.006 \text{ A} = 6 \text{ mA}$$

- b) Now, V_p is constant.

$$\delta I_p = 6 \text{ mA} = 0.006 \text{ A}$$

$$g_m = 0.0025 \text{ mho}$$

$$\delta V_g = (\delta I_p / g_m) / V_p = \text{constant.}$$

$$= \frac{0.006}{0.0025} = 2.4 \text{ V}$$

18. $r_p = 10 \text{ K}\Omega = 10 \times 10^3 \Omega$

$$\mu = 20 \quad V_p = 250 \text{ V}$$

$$V_g = -7.5 \text{ V} \quad I_p = 10 \text{ mA}$$

a) $g_m = \left(\frac{\delta I_p}{\delta V_g} \right) V_p = \text{constant}$

$$\Rightarrow \delta V_g = \frac{\delta I_p}{g_m} = \frac{15 \times 10^{-3} - 10 \times 10^{-3}}{\mu / r_p}$$

$$= \frac{5 \times 10^{-3}}{20 / 10 \times 10^3} = \frac{5}{2} = 2.5$$

$$r'_g = +2.5 - 7.5 = -5 \text{ V}$$

b) $r_p = \left(\frac{\delta V_p}{\delta I_p} \right) V_g = \text{constant}$

$$\Rightarrow 10^4 = \frac{\delta V_p}{(15 \times 10^{-3} - 10 \times 10^{-3})}$$

$$\Rightarrow \delta V_p = 10^4 \times 5 \times 10^{-3} = 50 \text{ V}$$

$$V'_p - V_p = 50 \Rightarrow V'_p = -50 + V_p = 200 \text{ V}$$

19. $V_p = 250 \text{ V}, V_g = -20 \text{ V}$

a) $i_p = 41(V_p + 7V_g)^{1.41}$

$$\Rightarrow 41(250 - 140)^{1.41} = 41 \times (110)^{1.41} = 30984 \mu\text{A} = 30 \text{ mA}$$

b) $i_p = 41(V_p + 7V_g)^{1.41}$

Differentiating,

$$di_p = 41 \times 1.41 \times (V_p + 7V_g)^{0.41} \times (dV_p + 7dV_g)$$

Now $r_p = \frac{dV_p}{di_p} V_g = \text{constant.}$

$$\text{or } \frac{dV_p}{di_p} = \frac{1 \times 10^6}{41 \times 1.41 \times 110^{0.41}} = 10^6 \times 2.51 \times 10^{-3} \Rightarrow 2.5 \times 10^3 \Omega = 2.5 \text{ K}\Omega$$

c) From above,

$$di_p = 41 \times 1.41 \times 6.87 \times 7 dV_g$$

$$g_m = \frac{di_p}{dV_g} = 41 \times 1.41 \times 6.87 \times 7 \mu \text{ mho}$$

$$= 2780 \mu \text{ mho} = 2.78 \text{ milli mho.}$$

d) Amplification factor

$$\mu = r_p \times g_m = 2.5 \times 10^3 \times 2.78 \times 10^{-3} = 6.95 = 7$$

20. $i_p = K(V_g + V_p/\mu)^{3/2} \quad \dots(1)$

Diff. the equation :

$$di_p = K \frac{3}{2} (V_g + V_p/\mu)^{1/2} dV_g$$

$$\Rightarrow \frac{di_p}{dV_g} = \frac{3}{2} K \left(V_g + \frac{V_0}{\mu} \right)^{1/2}$$

$$\Rightarrow g_m = 3/2 K (V_g + V_p/\mu)^{1/2} \quad \dots(2)$$

$$\text{From (1) } i_p = [3/2 K (V_g + V_p/\mu)^{1/2}]^3 \times 8/K^2 \quad 27$$

$$\Rightarrow i_p = k' (g_m)^3 \Rightarrow g_m \propto \sqrt[3]{i_p}$$

21. $r_p = 20 \text{ K}\Omega = \text{Plate Resistance}$

Mutual conductance = $g_m = 2.0 \text{ milli mho} = 2 \times 10^{-3} \text{ mho}$

Amplification factor $\mu = 30$

Load Resistance = $R_L = ?$

We know

$$A = \frac{\mu}{1 + \frac{r_p}{R_L}} \quad \text{where } A = \text{voltage amplification factor}$$

$$\Rightarrow A = \frac{r_p \times g_m}{1 + \frac{r_p}{R_L}} \quad \text{where } \mu = r_p \times g_m$$

$$\Rightarrow 30 = \frac{20 \times 10^3 \times 2 \times 10^{-3}}{1 + \frac{20000}{R_L}} \Rightarrow 3 = \frac{4R_L}{R_L + 20000}$$

$$\Rightarrow 3R_L + 60000 = 4 R_L$$

$$\Rightarrow R_L = 60000 \Omega = 60 \text{ K}\Omega$$

22. Voltage gain = $\frac{\mu}{1 + \frac{r_p}{R_L}}$

When $A = 10, R_L = 4 \text{ K}\Omega$

$$10 = \frac{\mu}{1 + \frac{r_p}{4 \times 10^3}} \Rightarrow 10 = \frac{\mu \times 4 \times 10^3}{4 \times 10^3 + r_p}$$

$$\Rightarrow 40 \times 10^3 + 10r_p = 4 \times 10^3 \mu \quad \dots(1)$$

when $A = 12, R_L = 8 \text{ K}\Omega$

$$12 = \frac{\mu}{1 + \frac{r_p}{8 \times 10^3}} \Rightarrow 12 = \frac{\mu \times 8 \times 10^3}{8 \times 10^3 + r_p}$$

$$\Rightarrow 96 \times 10^3 + 12 r_p = 8 \times 10^3 \mu \quad \dots(2)$$

Multiplying (2) in equation (1) and equating with equation (2)

$$2(40 \times 10^3 + 10 r_p) = 96 \times 10^3 + 12r_p$$

$$\Rightarrow r_p = 2 \times 10^3 \Omega = 2 \text{ K}\Omega$$

Putting the value in equation (1)

$$40 \times 10^3 + 10(2 \times 10^3) = 4 \times 10^3 \mu$$

$$\Rightarrow 40 \times 10^3 + 20 \times 10^3 = 4 \times 10^3 \mu$$

$$\Rightarrow \mu = 60/4 = 15$$



PHOTO ELECTRIC EFFECT AND WAVE PARTICLE QUALITY CHAPTER 42

1. $\lambda_1 = 400 \text{ nm}$ to $\lambda_2 = 780 \text{ nm}$

$$E = h\nu = \frac{hc}{\lambda} \quad h = 6.63 \times 10^{-34} \text{ J-s}, c = 3 \times 10^8 \text{ m/s}, \lambda_1 = 400 \text{ nm}, \lambda_2 = 780 \text{ nm}$$

$$E_1 = \frac{6.63 \times 10^{-34} \times 3 \times 10^8}{400 \times 10^{-9}} = \frac{6.63 \times 3}{4} \times 10^{-19} = 5 \times 10^{-19} \text{ J}$$

$$E_2 = \frac{6.63 \times 3}{7.8} \times 10^{-19} = 2.55 \times 10^{-19} \text{ J}$$

So, the range is $5 \times 10^{-19} \text{ J}$ to $2.55 \times 10^{-19} \text{ J}$.

2. $\lambda = h/p$

$$\Rightarrow P = h/\lambda = \frac{6.63 \times 10^{-34}}{500 \times 10^{-9}} \text{ J-S} = 1.326 \times 10^{-27} = 1.33 \times 10^{-27} \text{ kg-m/s.}$$

3. $\lambda_1 = 500 \text{ nm} = 500 \times 10^{-9} \text{ m}$, $\lambda_2 = 700 \text{ nm} = 700 \times 10^{-9} \text{ m}$

$$E_1 - E_2 = \text{Energy absorbed by the atom in the process.} = hc [1/\lambda_1 - 1/\lambda_2]$$

$$\Rightarrow 6.63 \times 3 [1/5 - 1/7] \times 10^{-19} = 1.136 \times 10^{-19} \text{ J}$$

4. $P = 10 \text{ W}$ \therefore E in 1 sec = 10 J % used to convert into photon = 60%

\therefore Energy used = 6 J

$$\text{Energy used to take out 1 photon} = hc/\lambda = \frac{6.63 \times 10^{-34} \times 3 \times 10^8}{590 \times 10^{-9}} = \frac{6.633}{590} \times 10^{-17}$$

$$\text{No. of photons used} = \frac{6}{\frac{6.63 \times 3}{590} \times 10^{-17}} = \frac{6 \times 590}{6.63 \times 3} \times 10^{17} = 176.9 \times 10^{17} = 1.77 \times 10^{19}$$

5. a) Here intensity = $I = 1.4 \times 10^3 \text{ W/m}^2$ Intensity, $I = \frac{\text{power}}{\text{area}} = 1.4 \times 10^3 \text{ W/m}^2$

Let no. of photons/sec emitted = n \therefore Power = Energy emitted/sec = $nhc/\lambda = P$

No. of photons/m² = $nhc/\lambda = \text{intensity}$

$$n = \frac{\text{intensity} \times \lambda}{hc} = \frac{1.9 \times 10^3 \times 5 \times 10^{-9}}{6.63 \times 10^{-34} \times 3 \times 10^8} = 3.5 \times 10^{21}$$

- b) Consider no. of two parts at a distance r and $r + dr$ from the source.

The time interval 'dt' in which the photon travel from one point to another = $dv/e = dt$.

$$\text{In this time the total no. of photons emitted} = N = n dt = \left(\frac{p\lambda}{hc} \right) \frac{dr}{C}$$

These points will be present between two spherical shells of radii ' r ' and $r+dr$. It is the distance of the 1st point from the sources. No. of photons per volume in the shell

$$(r + r + dr) = \frac{N}{2\pi r 2dr} = \frac{P\lambda dr}{hc^2} = \frac{1}{4\pi r^2 ch} = \frac{p\lambda}{4\pi hc^2 r^2}$$

In the case = $1.5 \times 10^{11} \text{ m}$, $\lambda = 500 \text{ nm}$, = $500 \times 10^{-9} \text{ m}$

$$\frac{P}{4\pi r^2} = 1.4 \times 10^3, \therefore \text{No. of photons/m}^3 = \frac{P}{4\pi r^2} \frac{\lambda}{hc^2}$$

$$= 1.4 \times 10^3 \times \frac{500 \times 10^{-9}}{6.63 \times 10^{-34} \times 3 \times 10^8} = 1.2 \times 10^{13}$$

- c) No. of photons = (No. of photons/sec/m²) \times Area

$$= (3.5 \times 10^{21}) \times 4\pi r^2$$

$$= 3.5 \times 10^{21} \times 4(3.14)(1.5 \times 10^{11})^2 = 9.9 \times 10^{44}$$

6. $\lambda = 663 \times 10^{-9} \text{ m}$, $\theta = 60^\circ$, $n = 1 \times 10^{19}$, $\lambda = h/p$

$\Rightarrow P = p/\lambda = 10^{-27}$

Force exerted on the wall = $n(mv \cos \theta - (-mv \cos \theta)) = 2n mv \cos \theta$.
 $= 2 \times 1 \times 10^{19} \times 10^{-27} \times \frac{1}{2} = 1 \times 10^{-8} \text{ N}$.

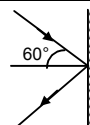

7. Power = 10 W P → Momentum

$\lambda = \frac{h}{p}$ or, $P = \frac{h}{\lambda}$ or, $\frac{P}{t} = \frac{h}{\lambda t}$

$E = \frac{hc}{\lambda}$ or, $\frac{E}{t} = \frac{hc}{\lambda t} = \text{Power (W)}$

$W = Pc/t$ or, $P/t = W/c = \text{force}$.

or Force = $7/10$ (absorbed) + $2 \times 3/10$ (reflected)

$= \frac{7}{10} \times \frac{W}{C} + 2 \times \frac{3}{10} \times \frac{W}{C} \Rightarrow \frac{7}{10} \times \frac{10}{3 \times 10^8} + 2 \times \frac{3}{10} \times \frac{10}{3 \times 10^8}$

$= 13/3 \times 10^{-8} = 4.33 \times 10^{-8} \text{ N}$.

8. $m = 20 \text{ g}$

The weight of the mirror is balanced. Thus force exerted by the photons is equal to weight

$P = \frac{h}{\lambda}$ $E = \frac{hc}{\lambda} = PC$

$\Rightarrow \frac{E}{t} = \frac{P}{t} C$

\Rightarrow Rate of change of momentum = Power/C

30% of light passes through the lens.

Thus it exerts force. 70% is reflected.

\therefore Force exerted = 2(rate of change of momentum)

$= 2 \times \text{Power}/C$

$30\% \left(\frac{2 \times \text{Power}}{C} \right) = mg$

$\Rightarrow \text{Power} = \frac{20 \times 10^{-3} \times 10 \times 3 \times 10^8 \times 10}{2 \times 3} = 10 \text{ w} = 100 \text{ MW}$.

9. Power = 100 W

Radius = 20 cm

60% is converted to light = 60 w

Now, Force = $\frac{\text{power}}{\text{velocity}} = \frac{60}{3 \times 10^8} = 2 \times 10^{-7} \text{ N}$.



Pressure = $\frac{\text{force}}{\text{area}} = \frac{2 \times 10^{-7}}{4 \times 3.14 \times (0.2)^2} = \frac{1}{8 \times 3.14} \times 10^{-5}$

$= 0.039 \times 10^{-5} = 3.9 \times 10^{-7} = 4 \times 10^{-7} \text{ N/m}^2$.

10. We know,

If a perfectly reflecting solid sphere of radius 'r' is kept in the path of a parallel beam of light of large aperture if intensity is I,

Force = $\frac{\pi r^2 I}{C}$

$I = 0.5 \text{ W/m}^2$, $r = 1 \text{ cm}$, $C = 3 \times 10^8 \text{ m/s}$

Force = $\frac{\pi \times (1)^2 \times 0.5}{3 \times 10^8} = \frac{3.14 \times 0.5}{3 \times 10^8}$

$= 0.523 \times 10^{-8} = 5.2 \times 10^{-9} \text{ N}$.

11. For a perfectly reflecting solid sphere of radius 'r' kept in the path of a parallel beam of light of large aperture with intensity 'I', force exerted = $\frac{\pi r^2 I}{C}$

12. If the e^- undergoes an elastic collision with a photon. Then applying energy conservation to this collision. We get, $hC/\lambda + m_0c^2 = mc^2$
and applying conservation of momentum $h/\lambda = mv$

$$\text{Mass of } e^- = m = \frac{m_0}{\sqrt{1 - v^2/c^2}}$$

from above equation it can be easily shown that

$$V = C \quad \text{or} \quad V = 0$$

both of these results have no physical meaning hence it is not possible for a photon to be completely absorbed by a free electron.

13. $r = 1 \text{ m}$

$$\text{Energy} = \frac{kq^2}{R} = \frac{kq^2}{1}$$

$$\text{Now, } \frac{kq^2}{1} = \frac{hc}{\lambda} \quad \text{or } \lambda = \frac{hc}{kq^2}$$

For max ' λ ', ' q ' should be min,
For minimum ' e^- ' = $1.6 \times 10^{-19} \text{ C}$

$$\text{Max } \lambda = \frac{hc}{kq^2} = 0.863 \times 10^3 = 863 \text{ m.}$$

$$\text{For next smaller wavelength} = \frac{6.63 \times 3 \times 10^{-34} \times 10^8}{9 \times 10^9 \times (1.6 \times 2)^2 \times 10^{-38}} = \frac{863}{4} = 215.74 \text{ m}$$

14. $\lambda = 350 \text{ nm} = 350 \times 10^{-9} \text{ m}$

$$\phi = 1.9 \text{ eV}$$

$$\begin{aligned} \text{Max KE of electrons} &= \frac{hc}{\lambda} - \phi = \frac{6.63 \times 10^{-34} \times 3 \times 10^8}{350 \times 10^{-9} \times 1.6 \times 10^{-19}} - 1.9 \\ &= 1.65 \text{ eV} = 1.6 \text{ eV.} \end{aligned}$$

15. $W_0 = 2.5 \times 10^{-19} \text{ J}$

a) We know $W_0 = h\nu_0$

$$\nu_0 = \frac{W_0}{h} = \frac{2.5 \times 10^{-19}}{6.63 \times 10^{-34}} = 3.77 \times 10^{14} \text{ Hz} = 3.8 \times 10^{14} \text{ Hz}$$

b) $eV_0 = h\nu - W_0$

$$\text{or, } V_0 = \frac{h\nu - W_0}{e} = \frac{6.63 \times 10^{-34} \times 6 \times 10^{14} - 2.5 \times 10^{-19}}{1.6 \times 10^{-19}} = 0.91 \text{ V}$$

16. $\phi = 4 \text{ eV} = 4 \times 1.6 \times 10^{-19} \text{ J}$

a) Threshold wavelength = λ

$$\phi = hc/\lambda$$

$$\Rightarrow \lambda = \frac{hc}{\phi} = \frac{6.63 \times 10^{-34} \times 3 \times 10^8}{4 \times 1.6 \times 10^{-19}} = \frac{6.63 \times 3}{6.4} \times \frac{10^{-27}}{10^{-9}} = 3.1 \times 10^{-7} \text{ m} = 310 \text{ nm.}$$

b) Stopping potential is 2.5 V

$$E = \phi + eV$$

$$\Rightarrow hc/\lambda = 4 \times 1.6 \times 10^{-19} + 1.6 \times 10^{-19} \times 2.5$$

$$\Rightarrow \lambda = \frac{6.63 \times 10^{-34} \times 3 \times 10^8}{\lambda \times 1.6 \times 10^{-19}} = 4 + 2.5$$

$$\Rightarrow \frac{6.63 \times 3 \times 10^{-26}}{1.6 \times 10^{-19} \times 6.5} = 1.9125 \times 10^{-7} = 190 \text{ nm.}$$

17. Energy of photoelectron

$$\Rightarrow \frac{1}{2} mv^2 = \frac{hc}{\lambda} - hv_0 = \frac{4.14 \times 10^{-15} \times 3 \times 10^8}{4 \times 10^{-7}} - 2.5 \text{ eV} = 0.605 \text{ eV.}$$

$$\text{We know } KE = \frac{P^2}{2m} \Rightarrow P^2 = 2m \times KE.$$

$$P^2 = 2 \times 9.1 \times 10^{-31} \times 0.605 \times 1.6 \times 10^{-19}$$

$$P = 4.197 \times 10^{-25} \text{ kg - m/s}$$

18. $\lambda = 400 \text{ nm} = 400 \times 10^{-9} \text{ m}$

$$V_0 = 1.1 \text{ V}$$

$$\frac{hc}{\lambda} = \frac{hc}{\lambda_0} + eV_0$$

$$\Rightarrow \frac{6.63 \times 10^{-34} \times 3 \times 10^8}{400 \times 10^{-9}} = \frac{6.63 \times 10^{-34} \times 3 \times 10^8}{\lambda_0} + 1.6 \times 10^{-19} \times 1.1$$

$$\Rightarrow 4.97 = \frac{19.89 \times 10^{-26}}{\lambda_0} + 1.76$$

$$\Rightarrow \frac{19.89 \times 10^{-26}}{\lambda_0} = 4.97 - 1.76 = 3.21$$

$$\Rightarrow \lambda_0 = \frac{19.89 \times 10^{-26}}{3.21} = 6.196 \times 10^{-7} \text{ m} = 620 \text{ nm.}$$

19. a) When $\lambda = 350$, $V_s = 1.45$

and when $\lambda = 400$, $V_s = 1$

$$\therefore \frac{hc}{350} = W + 1.45 \quad \dots(1)$$

$$\text{and } \frac{hc}{400} = W + 1 \quad \dots(2)$$

Subtracting (2) from (1) and solving to get the value of h we get

$$h = 4.2 \times 10^{-15} \text{ eV-sec}$$

b) Now work function = $w = \frac{hc}{\lambda} = \text{eV} - \text{s}$

$$= \frac{1240}{350} - 1.45 = 2.15 \text{ eV.}$$

c) $w = \frac{hc}{\lambda} = \lambda_{\text{there cathod}} = \frac{hc}{w}$

$$= \frac{1240}{2.15} = 576.8 \text{ nm.}$$

20. The electric field becomes 0 1.2×10^{45} times per second.

$$\therefore \text{Frequency} = \frac{1.2 \times 10^{15}}{2} = 0.6 \times 10^{15}$$

$$hv = \phi_0 + kE$$

$$\Rightarrow hv - \phi_0 = KE$$

$$\Rightarrow KE = \frac{6.63 \times 10^{-34} \times 0.6 \times 10^{15}}{1.6 \times 10^{-19}} - 2$$

$$= 0.482 \text{ eV} = 0.48 \text{ eV.}$$

21. $E = E_0 \sin[(1.57 \times 10^7 \text{ m}^{-1})(x - ct)]$

$$W = 1.57 \times 10^7 \times C$$

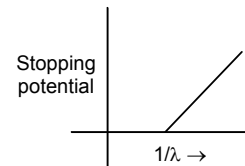

$$\Rightarrow f = \frac{1.57 \times 10^7 \times 3 \times 10^8}{2\pi} \text{ Hz} \quad W_0 = 1.9 \text{ eV}$$

Now $eV_0 = hf - W_0$

$$= 4.14 \times 10^{-15} \times \frac{1.57 \times 3 \times 10^{15}}{2\pi} - 1.9 \text{ eV}$$

$$= 3.105 - 1.9 = 1.205 \text{ eV}$$

$$\text{So, } V_0 = \frac{1.205 \times 1.6 \times 10^{-19}}{1.6 \times 10^{-19}} = 1.205 \text{ V.}$$

22. $E = 100 \sin[(3 \times 10^{15} \text{ s}^{-1})t] \sin [6 \times 10^{15} \text{ s}^{-1}]t]$
 $= 100 \times \frac{1}{2} [\cos[(9 \times 10^{15} \text{ s}^{-1})t] - \cos [3 \times 10^{15} \text{ s}^{-1}]t]$

The w are 9×10^{15} and 3×10^{15}

for largest K.E.

$$f_{\text{max}} = \frac{w_{\text{max}}}{2\pi} = \frac{9 \times 10^{15}}{2\pi}$$

$$E - \phi_0 = \text{K.E.}$$

$$\Rightarrow hf - \phi_0 = \text{K.E.}$$

$$\Rightarrow \frac{6.63 \times 10^{-34} \times 9 \times 10^{15}}{2\pi \times 1.6 \times 10^{-19}} - 2 = \text{KE}$$

$$\Rightarrow \text{KE} = 3.938 \text{ eV} = 3.93 \text{ eV.}$$

23. $W_0 = hf - eV_0$

$$= \frac{5 \times 10^{-3}}{8 \times 10^{15}} - 1.6 \times 10^{-19} \times 2 \text{ (Given } V_0 = 2\text{V, No. of photons} = 8 \times 10^{15}, \text{ Power} = 5 \text{ mW)}$$

$$= 6.25 \times 10^{-19} - 3.2 \times 10^{-19} = 3.05 \times 10^{-19} \text{ J}$$

$$= \frac{3.05 \times 10^{-19}}{1.6 \times 10^{-19}} = 1.906 \text{ eV.}$$

24. We have to take two cases :

Case I ... $v_0 = 1.656$

$$v = 5 \times 10^{14} \text{ Hz}$$

Case II... $v_0 = 0$

$$v = 1 \times 10^{14} \text{ Hz}$$

We know ;

a) $ev_0 = hf - w_0$

$$1.656e = h \times 5 \times 10^{14} - w_0 \quad \dots(1)$$

$$0 = 5h \times 10^{14} - 5w_0 \quad \dots(2)$$

$$1.656e = 4w_0$$

$$\Rightarrow w_0 = \frac{1.656}{4} \text{ eV} = 0.414 \text{ eV}$$

b) Putting value of w_0 in equation (2)

$$\Rightarrow 5w_0 = 5h \times 10^{14}$$

$$\Rightarrow 5 \times 0.414 = 5 \times h \times 10^{14}$$

$$\Rightarrow h = 4.414 \times 10^{-15} \text{ eV-s}$$

25. $w_0 = 0.6 \text{ eV}$

For w_0 to be min ' λ ' becomes maximum.

$$w_0 = \frac{hc}{\lambda} \text{ or } \lambda = \frac{hc}{w_0} = \frac{6.63 \times 10^{-34} \times 3 \times 10^8}{0.6 \times 1.6 \times 10^{-19}}$$

$$= 20.71 \times 10^{-7} \text{ m} = 2071 \text{ nm}$$

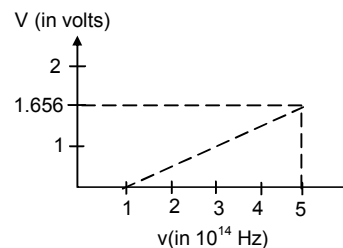

26. $\lambda = 400 \text{ nm}$, $P = 5 \text{ w}$

$$E \text{ of 1 photon} = \frac{hc}{\lambda} = \left(\frac{1242}{400} \right) \text{ eV}$$

$$\text{No. of electrons} = \frac{5}{\text{Energy of 1 photon}} = \frac{5 \times 400}{1.6 \times 10^{-19} \times 1242}$$

No. of electrons = 1 per 10^6 photon.

$$\text{No. of photoelectrons emitted} = \frac{5 \times 400}{1.6 \times 1242 \times 10^{-19} \times 10^6}$$

$$\text{Photo electric current} = \frac{5 \times 400}{1.6 \times 1242 \times 10^6 \times 10^{-19}} \times 1.6 \times 10^{-19} = 1.6 \times 10^{-6} \text{ A} = 1.6 \mu\text{A}.$$

27. $\lambda = 200 \text{ nm} = 2 \times 10^{-7} \text{ m}$

$$E \text{ of one photon} = \frac{hc}{\lambda} = \frac{6.63 \times 10^{-34} \times 3 \times 10^8}{2 \times 10^{-7}} = 9.945 \times 10^{-19}$$

$$\text{No. of photons} = \frac{1 \times 10^{-7}}{9.945 \times 10^{-19}} = 1 \times 10^{11} \text{ no.s}$$

$$\text{Hence, No. of photo electrons} = \frac{1 \times 10^{11}}{10^4} = 1 \times 10^7$$

Net amount of positive charge 'q' developed due to the outgoing electrons
 $= 1 \times 10^7 \times 1.6 \times 10^{-19} = 1.6 \times 10^{-12} \text{ C}.$

Now potential developed at the centre as well as at the surface due to these charges

$$= \frac{Kq}{r} = \frac{9 \times 10^9 \times 1.6 \times 10^{-12}}{4.8 \times 10^{-2}} = 3 \times 10^{-1} \text{ V} = 0.3 \text{ V}.$$

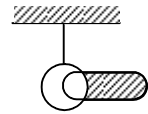

28. $\phi_0 = 2.39 \text{ eV}$

$\lambda_1 = 400 \text{ nm}$, $\lambda_2 = 600 \text{ nm}$

for B to the minimum energy should be maximum

$\therefore \lambda$ should be minimum.

$$E = \frac{hc}{\lambda} - \phi_0 = 3.105 - 2.39 = 0.715 \text{ eV}.$$

The presence of magnetic field will bend the beam there will be no current if the electron does not reach the other plates.

$$r = \frac{mv}{qB}$$

$$\Rightarrow r = \frac{\sqrt{2mE}}{qB}$$

$$\Rightarrow 0.1 = \frac{\sqrt{2 \times 9.1 \times 10^{-31} \times 1.6 \times 10^{-19} \times 0.715}}{1.6 \times 10^{-19} \times B}$$

$$\Rightarrow B = 2.85 \times 10^{-5} \text{ T}$$

29. Given : fringe width,

$$y = 1.0 \text{ mm} \times 2 = 2.0 \text{ mm}, D = 0.24 \text{ mm}, W_0 = 2.2 \text{ eV}, D = 1.2 \text{ m}$$

$$y = \frac{\lambda D}{d}$$

$$\text{or, } \lambda = \frac{y d}{D} = \frac{2 \times 10^{-3} \times 0.24 \times 10^{-3}}{1.2} = 4 \times 10^{-7} \text{ m}$$

$$E = \frac{hc}{\lambda} = \frac{4.14 \times 10^{-15} \times 3 \times 10^8}{4 \times 10^{-7}} = 3.105 \text{ eV}$$

$$\text{Stopping potential } eV_0 = 3.105 - 2.2 = 0.905 \text{ V}$$

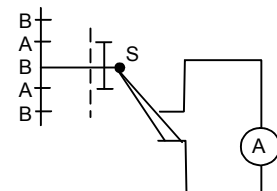
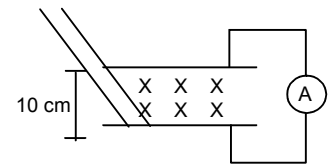

30. $\phi = 4.5 \text{ eV}, \lambda = 200 \text{ nm}$

$$\text{Stopping potential or energy} = E - \phi = \frac{WC}{\lambda} - \phi$$

Minimum 1.7 V is necessary to stop the electron

The minimum K.E. = 2eV

[Since the electric potential of 2 V is reqd. to accelerate the electron to reach the plates]
the maximum K.E. = (2+1, 7)ev = 3.7 ev.

31. Given

$$\sigma = 1 \times 10^{-9} \text{ cm}^{-2}, W_0 (C_s) = 1.9 \text{ eV}, d = 20 \text{ cm} = 0.20 \text{ m}, \lambda = 400 \text{ nm}$$

we know \rightarrow Electric potential due to a charged plate = $V = E \times d$

Where $E \rightarrow$ electric field due to the charged plate = σ/E_0

$d \rightarrow$ Separation between the plates.

$$V = \frac{\sigma}{E_0} \times d = \frac{1 \times 10^{-9} \times 20}{8.85 \times 10^{-12} \times 100} = 22.598 \text{ V} = 22.6$$

$$V_0 e = h\nu - w_0 = \frac{hc}{\lambda} - w_0 = \frac{4.14 \times 10^{-15} \times 3 \times 10^8}{4 \times 10^{-7}} - 1.9$$

$$= 3.105 - 1.9 = 1.205 \text{ ev}$$

or, $V_0 = 1.205 \text{ V}$

As V_0 is much less than 'V'

Hence the minimum energy required to reach the charged plate must be = 22.6 eV

For maximum KE, the V must be an accelerating one.

Hence max KE = $V_0 + V = 1.205 + 22.6 = 23.8005 \text{ ev}$

32. Here electric field of metal plate = $E = P/E_0$

$$= \frac{1 \times 10^{-19}}{8.85 \times 10^{-12}} = 113 \text{ v/m}$$

accl. $de = \phi = qE / m$

$$= \frac{1.6 \times 10^{-19} \times 113}{9.1 \times 10^{-31}} = 19.87 \times 10^{12}$$

$$t = \frac{\sqrt{2y}}{a} = \frac{\sqrt{2 \times 20 \times 10^{-2}}}{19.87 \times 10^{12}} = 1.41 \times 10^{-7} \text{ sec}$$

$$\text{K.E.} = \frac{hc}{\lambda} - w = 1.2 \text{ eV}$$

= $1.2 \times 1.6 \times 10^{-19} \text{ J}$ [because in previous problem i.e. in problem 31 : KE = 1.2 ev]

$$\therefore V = \frac{\sqrt{2KE}}{m} = \frac{\sqrt{2 \times 1.2 \times 1.6 \times 10^{-19}}}{4.1 \times 10^{-31}} = 0.665 \times 10^{-6}$$

\therefore Horizontal displacement = $V_t \times t$

$$= 0.655 \times 10^{-6} \times 1.4 \times 10^{-7} = 0.092 \text{ m} = 9.2 \text{ cm.}$$

33. When $\lambda = 250 \text{ nm}$

$$\text{Energy of photon} = \frac{hc}{\lambda} = \frac{1240}{250} = 4.96 \text{ ev}$$

$$\therefore \text{K.E.} = \frac{hc}{\lambda} - w = 4.96 - 1.9 \text{ ev} = 3.06 \text{ ev.}$$

Velocity to be non positive for each photo electron

The minimum value of velocity of plate should be = velocity of photo electron

$$\therefore \text{Velocity of photo electron} = \sqrt{2KE/m}$$

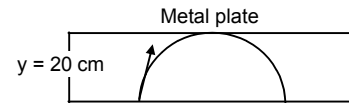

$$= \sqrt{\frac{3.06}{9.1 \times 10^{-31}}} = \sqrt{\frac{3.06 \times 1.6 \times 10^{-19}}{9.1 \times 10^{-31}}} = 1.04 \times 10^6 \text{ m/sec.}$$

34. Work function = ϕ , distance = d

The particle will move in a circle

When the stopping potential is equal to the potential due to the singly charged ion at that point.

$$eV_0 = \frac{hc}{\lambda} - \phi$$

$$\Rightarrow V_0 = \left(\frac{hc}{\lambda} - \phi \right) \frac{1}{e} \Rightarrow \frac{ke}{2d} = \left(\frac{hc}{\lambda} - \phi \right) \frac{1}{e}$$

$$\Rightarrow \frac{Ke^2}{2d} = \frac{hc}{\lambda} - \phi \Rightarrow \frac{hc}{\lambda} = \frac{Ke^2}{2d} + \phi = \frac{Ke^2 + 2d\phi}{2d}$$

$$\Rightarrow \lambda = \frac{hc \cdot 2d}{Ke^2 + 2d\phi} = \frac{2hcd}{\frac{1}{4\pi\epsilon_0 e^2} + 2d\phi} = \frac{8\pi\epsilon_0 hcd}{e^2 + 8\pi\epsilon_0 d\phi}$$

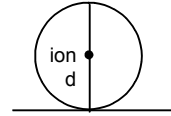

35. a) When $\lambda = 400 \text{ nm}$

$$\text{Energy of photon} = \frac{hc}{\lambda} = \frac{1240}{400} = 3.1 \text{ eV}$$

This energy given to electron

But for the first collision energy lost = $3.1 \text{ eV} \times 10\% = 0.31 \text{ eV}$

for second collision energy lost = $3.1 \text{ eV} \times 10\% = 0.31 \text{ eV}$

Total energy lost the two collision = $0.31 + 0.31 = 0.62 \text{ eV}$

K.E. of photon electron when it comes out of metal

= $hc/\lambda - \text{work function} - \text{Energy lost due to collision}$

= $3.1 \text{ eV} - 2.2 - 0.62 = 0.31 \text{ eV}$

b) For the 3rd collision the energy lost = 0.31 eV

Which just equate the KE lost in the 3rd collision electron. It just comes out of the metal

Hence in the fourth collision electron becomes unable to come out of the metal

Hence maximum number of collision = 4.



BOHR'S THEORY AND PHYSICS OF ATOM CHAPTER 43

$$1. \quad a_0 = \frac{\epsilon_0 h^2}{\pi m e^2} = \frac{A^2 T^2 (ML^2 T^{-1})^2}{L^2 M L T^{-2} M (AT)^2} = \frac{M^2 L^4 T^{-2}}{M^2 L^3 T^{-2}} = L$$

$\therefore a_0$ has dimensions of length.

$$2. \quad \text{We know, } \bar{\lambda} = 1/\lambda = 1.1 \times 10^7 \times (1/n_1^2 - 1/n_2^2)$$

$$a) \quad n_1 = 2, n_2 = 3$$

$$\text{or, } 1/\lambda = 1.1 \times 10^7 \times (1/4 - 1/9)$$

$$\text{or, } \lambda = \frac{36}{5 \times 1.1 \times 10^7} = 6.54 \times 10^{-7} = 654 \text{ nm}$$

$$b) \quad n_1 = 4, n_2 = 5$$

$$\bar{\lambda} = 1/\lambda = 1.1 \times 10^7 (1/16 - 1/25)$$

$$\text{or, } \lambda = \frac{400}{1.1 \times 10^7 \times 9} = 40.404 \times 10^{-7} \text{ m} = 4040.4 \text{ nm}$$

$$\text{for } R = 1.097 \times 10^7, \lambda = 4050 \text{ nm}$$

$$c) \quad n_1 = 9, n_2 = 10$$

$$1/\lambda = 1.1 \times 10^7 (1/81 - 1/100)$$

$$\text{or, } \lambda = \frac{8100}{19 \times 1.1 \times 10^7} = 387.5598 \times 10^{-7} = 38755.9 \text{ nm}$$

$$\text{for } R = 1.097 \times 10^7; \lambda = 38861.9 \text{ nm}$$

$$3. \quad \text{Small wave length is emitted i.e. longest energy}$$

$$n_1 = 1, n_2 = \infty$$

$$a) \quad \frac{1}{\lambda} = R \left(\frac{1}{n_1^2 - n_2^2} \right)$$

$$\Rightarrow \frac{1}{\lambda} = 1.1 \times 10^7 \left(\frac{1}{1 - \infty} \right)$$

$$\Rightarrow \lambda = \frac{1}{1.1 \times 10^7} = \frac{1}{1.1} \times 10^{-7} = 0.909 \times 10^{-7} = 90.9 \times 10^{-8} = 91 \text{ nm.}$$

$$b) \quad \frac{1}{\lambda} = z^2 R \left(\frac{1}{n_1^2 - n_2^2} \right)$$

$$\Rightarrow \lambda = \frac{1}{1.1 \times 10^7 z^2} = \frac{91 \text{ nm}}{4} = 23 \text{ nm}$$

$$c) \quad \frac{1}{\lambda} = z^2 R \left(\frac{1}{n_1^2 - n_2^2} \right)$$

$$\Rightarrow \lambda = \frac{91 \text{ nm}}{z^2} = \frac{91}{9} = 10 \text{ nm}$$

$$4. \quad \text{Rydberg's constant} = \frac{m e^4}{8 h^3 C \epsilon_0^2}$$

$$m_e = 9.1 \times 10^{-31} \text{ kg, } e = 1.6 \times 10^{-19} \text{ C, } h = 6.63 \times 10^{-34} \text{ J-S, } C = 3 \times 10^8 \text{ m/s, } \epsilon_0 = 8.85 \times 10^{-12}$$

$$\text{or, } R = \frac{9.1 \times 10^{-31} \times (1.6 \times 10^{-19})^4}{8 \times (6.63 \times 10^{-34})^3 \times 3 \times 10^8 \times (8.85 \times 10^{-12})^2} = 1.097 \times 10^7 \text{ m}^{-1}$$

$$5. \quad n_1 = 2, n_2 = \infty$$

$$E = \frac{-13.6}{n_1^2} - \frac{-13.6}{n_2^2} = 13.6 \left(\frac{1}{n_1^2} - \frac{1}{n_2^2} \right)$$

$$= 13.6 (1/\infty - 1/4) = -13.6/4 = -3.4 \text{ eV}$$

$$6. \text{ a) } n = 1, r = \frac{\epsilon_0 h^2 n^2}{\pi m Z e^2} = \frac{0.53 n^2}{Z} \text{ \AA}^\circ$$

$$= \frac{0.53 \times 1}{2} = 0.265 \text{ \AA}^\circ$$

$$\epsilon = \frac{-13.6 z^2}{n^2} = \frac{-13.6 \times 4}{1} = -54.4 \text{ eV}$$

$$\text{b) } n = 4, r = \frac{0.53 \times 16}{2} = 4.24 \text{ \AA}$$

$$\epsilon = \frac{-13.6 \times 4}{16} = -3.4 \text{ eV}$$

$$\text{c) } n = 10, r = \frac{0.53 \times 100}{2} = 26.5 \text{ \AA}$$

$$\epsilon = \frac{-13.6 \times 4}{100} = -0.544 \text{ eV}$$

7. As the light emitted lies in ultraviolet range the line lies in Lyman series.

$$\frac{1}{\lambda} = R \left(\frac{1}{n_1^2} - \frac{1}{n_2^2} \right)$$

$$\Rightarrow \frac{1}{102.5 \times 10^{-9}} = 1.1 \times 10^7 (1/n_1^2 - 1/n_2^2)$$

$$\Rightarrow \frac{10^9}{102.5} = 1.1 \times 10^7 (1 - 1/n_2^2) \Rightarrow \frac{10^2}{102.5} = 1.1 \times 10^7 (1 - 1/n_2^2)$$

$$\Rightarrow 1 - \frac{1}{n_2^2} = \frac{100}{102.5 \times 1.1} \Rightarrow \frac{1}{n_2^2} = \frac{1 - 100}{102.5 \times 1.1}$$

$$\Rightarrow n_2 = 2.97 \approx 3.$$

8. a) First excitation potential of

$$\text{He}^+ = 10.2 \times z^2 = 10.2 \times 4 = 40.8 \text{ V}$$

b) Ionization potential of Li^{++}

$$= 13.6 \text{ V} \times z^2 = 13.6 \times 9 = 122.4 \text{ V}$$

9. $n_1 = 4 \rightarrow n_2 = 2$

$n_1 = 4 \rightarrow 3 \rightarrow 2$

$$\frac{1}{\lambda} = 1.097 \times 10^7 \left(\frac{1}{16} - \frac{1}{4} \right)$$

$$\Rightarrow \frac{1}{\lambda} = 1.097 \times 10^7 \left(\frac{1-4}{16} \right) \Rightarrow \frac{1.097 \times 10^7 \times 3}{16}$$

$$\Rightarrow \lambda = \frac{16 \times 10^{-7}}{3 \times 1.097} = 4.8617 \times 10^{-7}$$

$$= 1.861 \times 10^{-9} = 487 \text{ nm}$$

$n_1 = 4$ and $n_2 = 3$

$$\frac{1}{\lambda} = 1.097 \times 10^7 \left(\frac{1}{16} - \frac{1}{9} \right)$$

$$\Rightarrow \frac{1}{\lambda} = 1.097 \times 10^7 \left(\frac{9-16}{144} \right) \Rightarrow \frac{1.097 \times 10^7 \times 7}{144}$$

$$\Rightarrow \lambda = \frac{144}{7 \times 1.097 \times 10^7} = 1875 \text{ nm}$$

$n_1 = 3 \rightarrow n_2 = 2$

$$\frac{1}{\lambda} = 1.097 \times 10^7 \left(\frac{1}{9} - \frac{1}{4} \right)$$

$$\Rightarrow \frac{1}{\lambda} = 1.097 \times 10^7 \left(\frac{4-9}{36} \right) \Rightarrow \frac{1.097 \times 10^7 \times 5}{66}$$

$$\Rightarrow \lambda = \frac{36 \times 10^{-7}}{5 \times 1.097} = 656 \text{ nm}$$

10. $\lambda = 228 \text{ \AA}$

$$E = \frac{hc}{\lambda} = \frac{6.63 \times 10^{-34} \times 3 \times 10^8}{228 \times 10^{-10}} = 0.0872 \times 10^{-16}$$

The transition takes place from $n = 1$ to $n = 2$

Now, ex. $13.6 \times 3/4 \times z^2 = 0.0872 \times 10^{-16}$

$$\Rightarrow z^2 = \frac{0.0872 \times 10^{-16} \times 4}{13.6 \times 3 \times 1.6 \times 10^{-19}} = 5.3$$

$$z = \sqrt{5.3} = 2.3$$

The ion may be Helium.

11. $F = \frac{q_1 q_2}{4\pi\epsilon_0 r^2}$

[Smallest dist. Between the electron and nucleus in the radius of first Bohr's orbit]

$$= \frac{(1.6 \times 10^{-19}) \times (1.6 \times 10^{-19}) \times 9 \times 10^9}{(0.53 \times 10^{-10})^2} = 82.02 \times 10^{-9} = 8.202 \times 10^{-8} = 8.2 \times 10^{-8} \text{ N}$$

12. a) From the energy data we see that the H atom transits from binding energy of 0.85 eV to excitation energy of 10.2 eV = Binding Energy of -3.4 eV.

So, $n = 4$ to $n = 2$

b) We know $= 1/\lambda = 1.097 \times 10^7 (1/4 - 1/16)$

$$\Rightarrow \lambda = \frac{16}{1.097 \times 3 \times 10^7} = 4.8617 \times 10^{-7} = 487 \text{ nm.}$$

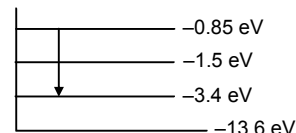

13. The second wavelength is from Balmer to Lyman i.e. from $n = 2$ to $n = 1$

$$n_1 = 2 \text{ to } n_2 = 1$$

$$\frac{1}{\lambda} = R \left(\frac{1}{n_1^2} - \frac{1}{n_2^2} \right)$$

$$\Rightarrow \frac{1}{\lambda} = 1.097 \times 10^7 \left(\frac{1}{2^2} - \frac{1}{1^2} \right) \Rightarrow 1.097 \times 10^7 \left(\frac{1}{4} - 1 \right)$$

$$\Rightarrow \lambda = \frac{4}{1.097 \times 3} \times 10^{-7}$$

$$= 1.215 \times 10^{-7} = 121.5 \times 10^{-9} = 122 \text{ nm.}$$

14. Energy at $n = 6$, $E = \frac{-13.6}{36} = -0.377777$

Energy in groundstate = -13.6 eV

Energy emitted in Second transition = $-13.6 - (-0.37777 + 1.13)$

$$= -12.09 = 12.1 \text{ eV}$$

b) Energy in the intermediate state = 1.13 eV + 0.0377777

$$= 1.507777 = \frac{13.6 \times z^2}{n^2} = \frac{13.6}{n^2}$$

$$\text{or, } n = \sqrt{\frac{13.6}{1.507}} = 3.03 = 3 = n.$$

15. The potential energy of a hydrogen atom is zero in ground state.

An electron is bound to the nucleus with energy 13.6 eV.,

Show we have to give energy of 13.6 eV. To cancel that energy.

Then additional 10.2 eV. is required to attain first excited state.

Total energy of an atom in the first excited state is = 13.6 eV. + 10.2 eV. = 23.8 eV.

16. Energy in ground state is the energy acquired in the transition of 2nd excited state to ground state.
As 2nd excited state is taken as zero level.

$$E = \frac{hc}{\lambda_1} = \frac{4.14 \times 10^{-15} \times 3 \times 10^8}{46 \times 10^{-9}} = \frac{1242}{46} = 27 \text{ eV.}$$

Again energy in the first excited state

$$E = \frac{hc}{\lambda_{II}} = \frac{4.14 \times 10^{-15} \times 3 \times 10^8}{103.5} = 12 \text{ eV.}$$

17. a) The gas emits 6 wavelengths, let it be in nth excited state.

$$\Rightarrow \frac{n(n-1)}{2} = 6 \Rightarrow n = 4 \quad \therefore \text{The gas is in 4}^{\text{th}} \text{ excited state.}$$

- b) Total no. of wavelengths in the transition is 6. We have $\frac{n(n-1)}{2} = 6 \Rightarrow n = 4$.

18. a) We know, $m v r = \frac{nh}{2\pi} \Rightarrow m r^2 \omega = \frac{nh}{2\pi} \Rightarrow \omega = \frac{hn}{2\pi \times m \times r^2}$

$$= \frac{1 \times 6.63 \times 10^{-34}}{2 \times 3.14 \times 9.1 \times 10^{-31} \times (0.53)^2 \times 10^{-20}} = 0.413 \times 10^{17} \text{ rad/s} = 4.13 \times 10^{17} \text{ rad/s.}$$

19. The range of Balmer series is 656.3 nm to 365 nm. It can resolve λ and $\lambda + \Delta\lambda$ if $\lambda/\Delta\lambda = 8000$.

$$\therefore \text{No. of wavelengths in the range} = \frac{656.3 - 365}{8000} = 36$$

Total no. of lines $36 + 2 = 38$ [extra two is for first and last wavelength]

20. a) $n_1 = 1, n_2 = 3, E = 13.6 (1/1 - 1/9) = 13.6 \times 8/9 = hc/\lambda$

$$\text{or, } \frac{13.6 \times 8}{9} = \frac{4.14 \times 10^{-15} \times 3 \times 10^8}{\lambda} \Rightarrow \lambda = \frac{4.14 \times 3 \times 10^{-7}}{13.6 \times 8} = 1.027 \times 10^{-7} = 103 \text{ nm.}$$

- b) As 'n' changes by 2, we may consider $n = 2$ to $n = 4$

$$\text{then } E = 13.6 \times (1/4 - 1/16) = 2.55 \text{ eV and } 2.55 = \frac{1242}{\lambda} \text{ or } \lambda = 487 \text{ nm.}$$

21. Frequency of the revolution in the ground state is $\frac{V_0}{2\pi r_0}$

[r_0 = radius of ground state, V_0 = velocity in the ground state]

$$\therefore \text{Frequency of radiation emitted is } \frac{V_0}{2\pi r_0} = f$$

$$\therefore C = f\lambda \Rightarrow \lambda = C/f = \frac{C2\pi r_0}{V_0}$$

$$\therefore \lambda = \frac{C2\pi r_0}{V_0} = 45.686 \text{ nm} = 45.7 \text{ nm.}$$

22. $KE = 3/2 KT = 1.5 KT, K = 8.62 \times 10^{-5} \text{ eV/k, Binding Energy} = -13.6 (1/\infty - 1/1) = 13.6 \text{ eV.}$

According to the question, $1.5 KT = 13.6$

$$\Rightarrow 1.5 \times 8.62 \times 10^{-5} \times T = 13.6$$

$$\Rightarrow T = \frac{13.6}{1.5 \times 8.62 \times 10^{-5}} = 1.05 \times 10^5 \text{ K}$$

No, because the molecule exists as H_2^+ which is impossible.

23. $K = 8.62 \times 10^{-5} \text{ eV/k}$

K.E. of H_2 molecules = $3/2 KT$

Energy released, when atom goes from ground state to $n = 3$

$$\Rightarrow 13.6 (1/1 - 1/9) \Rightarrow 3/2 KT = 13.6(1/1 - 1/9)$$

$$\Rightarrow 3/2 \times 8.62 \times 10^{-5} T = \frac{13.6 \times 8}{9}$$

$$\Rightarrow T = 0.9349 \times 10^5 = 9.349 \times 10^4 = 9.4 \times 10^4 \text{ K.}$$

24. $n = 2, T = 10^{-8} \text{ s}$

$$\text{Frequency} = \frac{me^4}{4\epsilon_0^2 n^3 h^3}$$

$$\text{So, time period} = 1/f = \frac{4\epsilon_0^2 n^3 h^3}{me^4} \Rightarrow \frac{4 \times (8.85)^2 \times 2^3 \times (6.63)^3}{9.1 \times (1.6)^4} \times \frac{10^{-24} - 10^{-102}}{10^{-76}}$$

$$= 12247.735 \times 10^{-19} \text{ sec.}$$

$$\text{No. of revolutions} = \frac{10^{-8}}{12247.735 \times 10^{-19}} = 8.16 \times 10^5$$

$$= 8.2 \times 10^6 \text{ revolution.}$$

25. Dipole moment (μ)

$$= n i A = 1 \times q/t A = qfA$$

$$= e \times \frac{me^4}{4\epsilon_0^2 h^3 n^3} \times (\pi r_0^2 n^2) = \frac{me^5 \times (\pi r_0^2 n^2)}{4\epsilon_0^2 h^3 n^3}$$

$$= \frac{(9.1 \times 10^{-31})(1.6 \times 10^{-19})^5 \times \pi \times (0.53)^2 \times 10^{-20} \times 1}{4 \times (8.85 \times 10^{-12})^2 (6.64 \times 10^{-34})^3 (1)^3}$$

$$= 0.0009176 \times 10^{-20} = 9.176 \times 10^{-24} \text{ A} \cdot \text{m}^2.$$

26. Magnetic Dipole moment = $n i A = \frac{e \times me^4 \times \pi r_0^2 n^2}{4\epsilon_0^2 h^3 n^3}$

$$\text{Angular momentum} = mvr = \frac{nh}{2\pi}$$

Since the ratio of magnetic dipole moment and angular momentum is independent of Z .
Hence it is an universal constant.

$$\text{Ratio} = \frac{e^5 \times m \times \pi r_0^2 n^2}{24\epsilon_0^2 h^3 n^3} \times \frac{2\pi}{nh} \Rightarrow \frac{(1.6 \times 10^{-19})^5 \times (9.1 \times 10^{-31}) \times (3.14)^2 \times (0.53 \times 10^{-10})^2}{2 \times (8.85 \times 10^{-12})^2 \times (6.63 \times 10^{-34})^4 \times 1^2}$$

$$= 8.73 \times 10^{10} \text{ C/kg.}$$

27. The energies associated with 450 nm radiation = $\frac{1242}{450} = 2.76 \text{ eV}$

$$\text{Energy associated with 550 nm radiation} = \frac{1242}{550} = 2.258 = 2.26 \text{ eV.}$$

The light comes under visible range

Thus, $n_1 = 2, n_2 = 3, 4, 5, \dots$

$$E_2 - E_3 = 13.6 (1/2^2 - 1/3^2) = 1.9 \text{ eV}$$

$$E_2 - E_4 = 13.6 (1/4 - 1/16) = 2.55 \text{ eV}$$

$$E_2 - E_5 = 13.6 (1/4 - 1/25) = 2.856 \text{ eV}$$

Only $E_2 - E_4$ comes in the range of energy provided. So the wavelength corresponding to that energy will be absorbed.

$$\lambda = \frac{1242}{2.55} = 487.05 \text{ nm} = 487 \text{ nm}$$

487 nm wavelength will be absorbed.

28. From transitions $n = 2$ to $n = 1$.

$$E = 13.6 (1/1 - 1/4) = 13.6 \times 3/4 = 10.2 \text{ eV}$$

Let in check the transitions possible on He. $n = 1$ to 2

$$E_1 = 4 \times 13.6 (1 - 1/4) = 40.8 \text{ eV} \quad [E_1 > E \text{ hence it is not possible}]$$

$n = 1$ to $n = 3$

$$E_2 = 4 \times 13.6 (1 - 1/9) = 48.3 \text{ eV} \quad [E_2 > E \text{ hence impossible}]$$

Similarly $n = 1$ to $n = 4$ is also not possible.

$n = 2$ to $n = 3$

$$E_3 = 4 \times 13.6 (1/4 - 1/9) = 7.56 \text{ eV}$$

$$n = 2 \text{ to } n = 4$$

$$E_4 = 4 \times 13.6 (1/4 - 1/16) = 10.2 \text{ eV}$$

As, $E_3 < E$ and $E_4 = E$

Hence E_3 and E_4 can be possible.

29. $\lambda = 50 \text{ nm}$

Work function = Energy required to remove the electron from $n_1 = 1$ to $n_2 = \infty$.

$$E = 13.6 (1/1 - 1/\infty) = 13.6$$

$$\frac{hc}{\lambda} - 13.6 = KE$$

$$\Rightarrow \frac{1242}{50} - 13.6 = KE \Rightarrow KE = 24.84 - 13.6 = 11.24 \text{ eV.}$$

30. $\lambda = 100 \text{ nm}$

$$E = \frac{hc}{\lambda} = \frac{1242}{100} = 12.42 \text{ eV}$$

a) The possible transitions may be E_1 to E_2

E_1 to E_2 , energy absorbed = 10.2 eV

Energy left = 12.42 - 10.2 = 2.22 eV

$$2.22 \text{ eV} = \frac{hc}{\lambda} = \frac{1242}{\lambda} \quad \text{or} \quad \lambda = \frac{1242}{2.22} = 559.45 = 560 \text{ nm}$$

E_1 to E_3 , Energy absorbed = 12.1 eV

Energy left = 12.42 - 12.1 = 0.32 eV

$$0.32 = \frac{hc}{\lambda} = \frac{1242}{\lambda} \quad \text{or} \quad \lambda = \frac{1242}{0.32} = 3881.2 = 3881 \text{ nm}$$

E_3 to E_4 , Energy absorbed = 0.65 eV

Energy left = 12.42 - 0.65 = 11.77 eV

$$11.77 = \frac{hc}{\lambda} = \frac{1242}{\lambda} \quad \text{or} \quad \lambda = \frac{1242}{11.77} = 105.52$$

b) The energy absorbed by the H atom is now radiated perpendicular to the incident beam.

$$\rightarrow 10.2 = \frac{hc}{\lambda} \quad \text{or} \quad \lambda = \frac{1242}{10.2} = 121.76 \text{ nm}$$

$$\rightarrow 12.1 = \frac{hc}{\lambda} \quad \text{or} \quad \lambda = \frac{1242}{12.1} = 102.64 \text{ nm}$$

$$\rightarrow 0.65 = \frac{hc}{\lambda} \quad \text{or} \quad \lambda = \frac{1242}{0.65} = 1910.76 \text{ nm}$$

31. $\phi = 1.9 \text{ eV}$

a) The hydrogen is ionized

$$n_1 = 1, n_2 = \infty$$

Energy required for ionization = 13.6 ($1/n_1^2 - 1/n_2^2$) = 13.6

$$\frac{hc}{\lambda} - 1.9 = 13.6 \Rightarrow \lambda = 80.1 \text{ nm} = 80 \text{ nm.}$$

b) For the electron to be excited from $n_1 = 1$ to $n_2 = 2$

$$E = 13.6 (1/n_1^2 - 1/n_2^2) = 13.6(1 - 1/4) = \frac{13.6 \times 3}{4}$$

$$\frac{hc}{\lambda} - 1.9 = \frac{13.6 \times 3}{4} \Rightarrow \lambda = 1242 / 12.1 = 102.64 = 102 \text{ nm.}$$

32. The given wavelength in Balmer series.

The first line, which requires minimum energy is from $n_1 = 3$ to $n_2 = 2$.

\therefore The energy should be equal to the energy required for transition from ground state to $n = 3$.

i.e. $E = 13.6 [1 - (1/9)] = 12.09 \text{ eV}$

\therefore Minimum value of electric field = 12.09 v/m = 12.1 v/m

33. In one dimensional elastic collision of two bodies of equal masses.

The initial velocities of bodies are interchanged after collision.

∴ Velocity of the neutron after collision is zero.

Hence, it has zero energy.

34. The hydrogen atoms after collision move with speeds v_1 and v_2 .

$$mv = mv_1 + mv_2 \quad \dots(1)$$

$$\frac{1}{2}mv^2 = \frac{1}{2}mv_1^2 + \frac{1}{2}mv_2^2 + \Delta E \quad \dots(2)$$

$$\text{From (1) } v^2 = (v_1 + v_2)^2 = v_1^2 + v_2^2 + 2v_1v_2$$

$$\text{From (2) } v^2 = v_1^2 + v_2^2 + 2\Delta E/m$$

$$= 2v_1v_2 = \frac{2\Delta E}{m} \quad \dots(3)$$

$$(v_1 - v_2)^2 = (v_1 + v_2)^2 - 4v_1v_2$$

$$\Rightarrow (v_1 - v_2) = v^2 - 4\Delta E/m$$

For minimum value of 'v'

$$v_1 = v_2 \Rightarrow v^2 - (4\Delta E/m) = 0$$

$$\Rightarrow v^2 = \frac{4\Delta E}{m} = \frac{4 \times 13.6 \times 1.6 \times 10^{-19}}{1.67 \times 10^{-27}}$$

$$\Rightarrow v = \sqrt{\frac{4 \times 13.6 \times 1.6 \times 10^{-19}}{1.67 \times 10^{-27}}} = 7.2 \times 10^4 \text{ m/s.}$$

35. Energy of the neutron is $\frac{1}{2}mv^2$.

The condition for inelastic collision is $\Rightarrow \frac{1}{2}mv^2 > 2\Delta E$

$$\Rightarrow \Delta E = \frac{1}{4}mv^2$$

ΔE is the energy absorbed.

Energy required for first excited state is 10.2 eV.

∴ $\Delta E < 10.2 \text{ eV}$

$$\therefore 10.2 \text{ eV} < \frac{1}{4}mv^2 \Rightarrow v_{\min} = \sqrt{\frac{4 \times 10.2}{m}} \text{ eV}$$

$$\Rightarrow v = \sqrt{\frac{10.2 \times 1.6 \times 10^{-19} \times 4}{1.67 \times 10^{-27}}} = 6 \times 10^4 \text{ m/sec.}$$

36. a) $\lambda = 656.3 \text{ nm}$

$$\text{Momentum } P = E/c = \frac{hc}{\lambda} \times \frac{1}{c} = \frac{h}{\lambda} = \frac{6.63 \times 10^{-34}}{656.3 \times 10^{-9}} = 0.01 \times 10^{-25} = 1 \times 10^{-27} \text{ kg-m/s}$$

$$\text{b) } 1 \times 10^{-27} = 1.67 \times 10^{-27} \times v$$

$$\Rightarrow v = 1/1.67 = 0.598 = 0.6 \text{ m/s}$$

$$\text{c) KE of atom} = \frac{1}{2} \times 1.67 \times 10^{-27} \times (0.6)^2 = \frac{0.3006 \times 10^{-27}}{1.6 \times 10^{-19}} \text{ eV} = 1.9 \times 10^{-9} \text{ eV.}$$

37. Difference in energy in the transition from $n = 3$ to $n = 2$ is 1.89 eV.

Let recoil energy be E .

$$\frac{1}{2}m_e [V_2^2 - V_3^2] + E = 1.89 \text{ eV} \Rightarrow 1.89 \times 1.6 \times 10^{-19} \text{ J}$$

$$\therefore \frac{1}{2} \times 9.1 \times 10^{-31} \left[\left(\frac{2187}{2} \right)^2 - \left(\frac{2187}{3} \right)^2 \right] + E = 3.024 \times 10^{-19} \text{ J}$$

$$\Rightarrow E = 3.024 \times 10^{-19} - 3.0225 \times 10^{-25}$$

38. $n_1 = 2, n_2 = 3$

Energy possessed by H_α light

$$= 13.6 \left(\frac{1}{n_1^2} - \frac{1}{n_2^2} \right) = 13.6 \times \left(\frac{1}{4} - \frac{1}{9} \right) = 1.89 \text{ eV.}$$

For H_α light to be able to emit photoelectrons from a metal the work function must be greater than or equal to 1.89 eV.

39. The maximum energy liberated by the Balmer Series is $n_1 = 2, n_2 = \infty$

$$E = 13.6(1/n_1^2 - 1/n_2^2) = 13.6 \times 1/4 = 3.4 \text{ eV}$$

3.4 eV is the maximum work function of the metal.

40. $\phi = 1.9 \text{ eV}$

The radiations coming from the hydrogen discharge tube consist of photons of energy = 13.6 eV.

Maximum KE of photoelectrons emitted

$$= \text{Energy of Photons} - \text{Work function of metal.}$$

$$= 13.6 \text{ eV} - 1.9 \text{ eV} = 11.7 \text{ eV}$$

41. $\lambda = 440 \text{ nm}$, $e = \text{Charge of an electron}$, $\phi = 2 \text{ eV}$, $V_0 = \text{stopping potential}$.

$$\text{We have, } \frac{hc}{\lambda} - \phi = eV_0 \Rightarrow \frac{4.14 \times 10^{-15} \times 3 \times 10^8}{440 \times 10^{-9}} - 2\text{eV} = eV_0$$

$$\Rightarrow eV_0 = 0.823 \text{ eV} \Rightarrow V_0 = 0.823 \text{ volts.}$$

42. Mass of Earth = $M_e = 6.0 \times 10^{24} \text{ kg}$

$$\text{Mass of Sun} = M_s = 2.0 \times 10^{30} \text{ kg}$$

$$\text{Earth - Sun dist} = 1.5 \times 10^{11} \text{ m}$$

$$mvr = \frac{nh}{2\pi} \text{ or, } m^2 v^2 r^2 = \frac{n^2 h^2}{4\pi^2} \quad \dots(1)$$

$$\frac{GM_e M_s}{r^2} = \frac{M_e v^2}{r} \text{ or } v^2 = GM_s/r \quad \dots(2)$$

Dividing (1) and (2)

$$\text{We get } M_e^2 r = \frac{n^2 h^2}{4\pi^2 GM_s}$$

for $n = 1$

$$r = \sqrt{\frac{h^2}{4\pi^2 GM_s M_e^2}} = 2.29 \times 10^{-138} \text{ m} = 2.3 \times 10^{-138} \text{ m.}$$

$$\text{b) } n^2 = \frac{M_e^2 \times r \times 4 \times \pi^2 \times G \times M_s}{h^2} = 2.5 \times 10^{74}.$$

43. $m_e v r = \frac{nh}{2\pi} \quad \dots(1)$

$$\frac{GM_n M_e}{r^2} = \frac{m_e v^2}{r} \Rightarrow \frac{GM_n}{r} = v^2 \quad \dots(2)$$

Squaring (2) and dividing it with (1)

$$\frac{m_e^2 v^2 r^2}{v^2} = \frac{n^2 h^2 r}{4\pi^2 G m_n} \Rightarrow m_e^2 r = \frac{n^2 h^2 r}{4\pi^2 G m_n} \Rightarrow r = \frac{n^2 h^2 r}{4\pi^2 G m_n m_e^2}$$

$$\Rightarrow v = \frac{nh}{2\pi r m_e} \text{ from (1)}$$

$$\Rightarrow v = \frac{nh 4\pi^2 GM_n M_e^2}{2\pi M_e n^2 h^2} = \frac{2\pi GM_n M_e}{nh}$$

$$\text{KE} = \frac{1}{2} m_e v^2 = \frac{1}{2} m_e \frac{(2\pi GM_n M_e)^2}{n^2 h^2} = \frac{4\pi^2 G^2 M_n^2 M_e^3}{2n^2 h^2}$$

$$\text{PE} = \frac{-GM_n M_e}{r} = \frac{-GM_n M_e 4\pi^2 GM_n M_e^2}{n^2 h^2} = \frac{-4\pi^2 G^2 M_n^2 M_e^3}{n^2 h^2}$$

$$\text{Total energy} = \text{KE} + \text{PE} = \frac{2\pi^2 G^2 M_n^2 M_e^3}{2n^2 h^2}$$

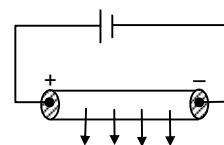

44. According to Bohr's quantization rule

$$mvr = \frac{nh}{2\pi}$$

'r' is less when 'n' has least value i.e. 1

$$\text{or, } mv = \frac{nh}{2\pi R} \quad \dots(1)$$

$$\text{Again, } r = \frac{mv}{qB}, \quad \text{or, } mv = rqB \quad \dots(2)$$

From (1) and (2)

$$rqB = \frac{nh}{2\pi r} \quad [q = e]$$

$$\Rightarrow r^2 = \frac{nh}{2\pi eB} \Rightarrow r = \sqrt{h/2\pi eB} \quad [\text{here } n = 1]$$

$$\text{b) For the radius of } n\text{th orbit, } r = \sqrt{\frac{nh}{2\pi eB}}.$$

$$\text{c) } mvr = \frac{nh}{2\pi}, \quad r = \frac{mv}{qB}$$

Substituting the value of 'r' in (1)

$$mv \times \frac{mv}{qB} = \frac{nh}{2\pi}$$

$$\Rightarrow m^2 v^2 = \frac{nheB}{2\pi} \quad [n = 1, q = e]$$

$$\Rightarrow v^2 = \frac{heB}{2\pi m^2} \Rightarrow \text{or } v = \sqrt{\frac{heB}{2\pi m^2}}.$$

45. even quantum numbers are allowed

$n_1 = 2, n_2 = 4 \rightarrow$ For minimum energy or for longest possible wavelength.

$$E = 13.6 \left(\frac{1}{n_1^2} - \frac{1}{n_2^2} \right) = 13.6 \left(\frac{1}{2^2} - \frac{1}{4^2} \right) = 2.55$$

$$\Rightarrow 2.55 = \frac{hc}{\lambda}$$

$$\Rightarrow \lambda = \frac{hc}{2.55} = \frac{1242}{2.55} = 487.05 \text{ nm} = 487 \text{ nm}$$

46. Velocity of hydrogen atom in state 'n' = u

Also the velocity of photon = u

But $u \ll C$

Here the photon is emitted as a wave.

So its velocity is same as that of hydrogen atom i.e. u.

\therefore According to Doppler's effect

$$\text{frequency } v = v_0 \left(\frac{1+u/c}{1-u/c} \right)$$

$$\text{as } u \ll C \quad 1 - \frac{u}{c} = q$$

$$\therefore v = v_0 \left(\frac{1+u/c}{1} \right) = v_0 \left(1 + \frac{u}{c} \right) \Rightarrow v = v_0 \left(1 + \frac{u}{c} \right)$$



X - RAYS CHAPTER 44

1. $\lambda = 0.1 \text{ nm}$
 - a) Energy = $\frac{hc}{\lambda} = \frac{1242 \text{ eV}\cdot\text{nm}}{0.1 \text{ nm}}$
 $= 12420 \text{ eV} = 12.42 \text{ KeV} = 12.4 \text{ keV}.$
 - b) Frequency = $\frac{C}{\lambda} = \frac{3 \times 10^8}{0.1 \times 10^{-9}} = \frac{3 \times 10^8}{10^{-10}} = 3 \times 10^{18} \text{ Hz}$
 - c) Momentum = $E/C = \frac{12.4 \times 10^3 \times 1.6 \times 10^{-19}}{3 \times 10^8} = 6.613 \times 10^{-24} \text{ kg}\cdot\text{m/s} = 6.62 \times 10^{-24} \text{ kg}\cdot\text{m/s}.$
2. Distance = $3 \text{ km} = 3 \times 10^3 \text{ m}$
 $C = 3 \times 10^8 \text{ m/s}$
 $t = \frac{\text{Dist}}{\text{Speed}} = \frac{3 \times 10^3}{3 \times 10^8} = 10^{-5} \text{ sec.}$
 $\Rightarrow 10 \times 10^{-8} \text{ sec} = 10 \mu\text{s}$ in both case.
3. $V = 30 \text{ KV}$
 $\lambda = \frac{hc}{E} = \frac{hc}{eV} = \frac{1242 \text{ eV}\cdot\text{nm}}{e \times 30 \times 10^3} = 414 \times 10^{-4} \text{ nm} = 41.4 \text{ Pm}.$
4. $\lambda = 0.10 \text{ nm} = 10^{-10} \text{ m}; \quad h = 6.63 \times 10^{-34} \text{ J}\cdot\text{s}$
 $C = 3 \times 10^8 \text{ m/s}; \quad e = 1.6 \times 10^{-19} \text{ C}$
 $\lambda_{\min} = \frac{hc}{eV} \quad \text{or} \quad V = \frac{hc}{e\lambda}$
 $= \frac{6.63 \times 10^{-34} \times 3 \times 10^8}{1.6 \times 10^{-19} \times 10^{-10}} = 12.43 \times 10^3 \text{ V} = 12.4 \text{ KV}.$
 Max. Energy = $\frac{hc}{\lambda} = \frac{6.63 \times 10^{-34} \times 3 \times 10^8}{10^{-10}} = 19.89 \times 10^{-18} = 1.989 \times 10^{-15} = 2 \times 10^{-15} \text{ J}.$
5. $\lambda = 80 \text{ pm}, E = \frac{hc}{\lambda} = \frac{1242}{80 \times 10^{-3}} = 15.525 \times 10^3 \text{ eV} = 15.5 \text{ KeV}$
6. We know $\lambda = \frac{hc}{V}$
 Now $\lambda = \frac{hc}{1.01V} = \frac{\lambda}{1.01}$
 $\lambda - \lambda' = \frac{0.01}{1.01} \lambda.$
 $\% \text{ change of wave length} = \frac{0.01 \times \lambda}{1.01 \times \lambda} \times 100 = \frac{1}{1.01} = 0.9900 = 1\%.$
7. $d = 1.5 \text{ m}, \lambda = 30 \text{ pm} = 30 \times 10^{-3} \text{ nm}$
 $E = \frac{hc}{\lambda} = \frac{1242}{30 \times 10^{-3}} = 41.4 \times 10^3 \text{ eV}$
 Electric field = $\frac{V}{d} = \frac{41.4 \times 10^3}{1.5} = 27.6 \times 10^3 \text{ V/m} = 27.6 \text{ KV/m}.$
8. Given $\lambda' = \lambda - 26 \text{ pm}, V' = 1.5 \text{ V}$
 Now, $\lambda = \frac{hc}{eV}, \quad \lambda' = \frac{hc}{eV'}$
 or $\lambda V = \lambda' V'$
 $\Rightarrow \lambda V = (\lambda - 26 \times 10^{-12}) \times 1.5 \text{ V}$

$$\Rightarrow \lambda = 1.5 \lambda - 1.5 \times 26 \times 10^{-12}$$

$$\Rightarrow \lambda = \frac{39 \times 10^{-12}}{0.5} = 78 \times 10^{-12} \text{ m}$$

$$V = \frac{hc}{e\lambda} = \frac{6.63 \times 3 \times 10^{-34} \times 10^8}{1.6 \times 10^{-19} \times 78 \times 10^{-12}} = 0.15937 \times 10^5 = 15.93 \times 10^3 \text{ V} = 15.93 \text{ KV.}$$

9. $V = 32 \text{ KV} = 32 \times 10^3 \text{ V}$

When accelerated through 32 KV

$$E = 32 \times 10^3 \text{ eV}$$

$$\lambda = \frac{hc}{E} = \frac{1242}{32 \times 10^3} = 38.8 \times 10^{-3} \text{ nm} = 38.8 \text{ pm.}$$

10. $\lambda = \frac{hc}{eV}$; $V = 40 \text{ kV}$, $f = 9.7 \times 10^{18} \text{ Hz}$

$$\text{or, } \frac{h}{c} = \frac{h}{eV} ; \text{ or, } \frac{i}{f} = \frac{h}{eV} ; \text{ or } h = \frac{eV}{f} \text{ V-s}$$

$$= \frac{eV}{f} \text{ V-s} = \frac{40 \times 10^3}{9.7 \times 10^{18}} = 4.12 \times 10^{-15} \text{ eV-s.}$$

11. $V = 40 \text{ KV} = 40 \times 10^3 \text{ V}$

$$\text{Energy} = 40 \times 10^3 \text{ eV}$$

$$\text{Energy utilized} = \frac{70}{100} \times 40 \times 10^3 = 28 \times 10^3 \text{ eV}$$

$$\lambda = \frac{hc}{E} = \frac{1242 - \text{ev nm}}{28 \times 10^3 \text{ ev}} \Rightarrow 44.35 \times 10^{-3} \text{ nm} = 44.35 \text{ pm.}$$

For other wavelengths,

$$E = 70\% \text{ (left over energy)} = \frac{70}{100} \times (40 - 28)10^3 = 84 \times 10^2.$$

$$\lambda' = \frac{hc}{E} = \frac{1242}{8.4 \times 10^3} = 147.86 \times 10^{-3} \text{ nm} = 147.86 \text{ pm} = 148 \text{ pm.}$$

For third wavelength,

$$E = \frac{70}{100} = (12 - 8.4) \times 10^3 = 7 \times 3.6 \times 10^2 = 25.2 \times 10^2$$

$$\lambda' = \frac{hc}{E} = \frac{1242}{25.2 \times 10^2} = 49.2857 \times 10^{-2} \text{ nm} = 493 \text{ pm.}$$

12. $K_\alpha = 21.3 \times 10^{-12} \text{ pm}$, Now, $E_K - E_L = \frac{1242}{21.3 \times 10^{-3}} = 58.309 \text{ kev}$

$$E_L = 11.3 \text{ kev,}$$

$$E_K = 58.309 + 11.3 = 69.609 \text{ kev}$$

$$\text{Now, } V_e = 69.609 \text{ KeV, or } V = 69.609 \text{ KV.}$$

13. $\lambda = 0.36 \text{ nm}$

$$E = \frac{1242}{0.36} = 3450 \text{ eV } (E_M - E_K)$$

Energy needed to ionize an organ atom = 16 eV

Energy needed to knock out an electron from K-shell

$$= (3450 + 16) \text{ eV} = 3466 \text{ eV} = 3.466 \text{ KeV.}$$

14. $\lambda_1 = 887 \text{ pm}$

$$v = \frac{C}{\lambda} = \frac{3 \times 10^8}{887 \times 10^{-12}} = 3.382 \times 10^7 = 33.82 \times 10^{16} = 5.815 \times 10^8$$

$$\lambda_2 = 146 \text{ pm}$$

$$v = \frac{3 \times 10^8}{146 \times 10^{-12}} = 0.02054 \times 10^{20} = 2.054 \times 10^{18} = 1.4331 \times 10^9.$$

We know, $\sqrt{v} = a(z - b)$

$$\Rightarrow \frac{\sqrt{5.815 \times 10^8}}{\sqrt{1.4331 \times 10^9}} = \frac{a(13 - b)}{a(30 - b)}$$

$$\Rightarrow \frac{13 - b}{30 - b} = \frac{5.815 \times 10^{-1}}{1.4331} = 0.4057.$$

$$\Rightarrow 30 \times 0.4057 - 0.4057 b = 13 - b$$

$$\Rightarrow 12.171 - 0.4.57 b + b = 13$$

$$\Rightarrow b = \frac{0.829}{0.5943} = 1.39491$$

$$\Rightarrow a = \frac{5.815 \times 10^8}{11.33} = 0.51323 \times 10^8 = 5 \times 10^7.$$

For 'Fe',

$$\sqrt{v} = 5 \times 10^7 (26 - 1.39) = 5 \times 24.61 \times 10^7 = 123.05 \times 10^7$$

$$c/\lambda = 15141.3 \times 10^{14}$$

$$= \lambda = \frac{3 \times 10^8}{15141.3 \times 10^{14}} = 0.000198 \times 10^{-6} \text{ m} = 198 \times 10^{-12} = 198 \text{ pm}.$$

15. $E = 3.69 \text{ kev} = 3690 \text{ eV}$

$$\lambda = \frac{hc}{E} = \frac{1242}{3690} = 0.33658 \text{ nm}$$

$$\sqrt{c/\lambda} = a(z - b); \quad a = 5 \times 10^7 \sqrt{\text{Hz}}, \quad b = 1.37 \text{ (from previous problem)}$$

$$\sqrt{\frac{3 \times 10^8}{0.34 \times 10^{-9}}} = 5 \times 10^7 (Z - 1.37) \Rightarrow \sqrt{8.82 \times 10^{17}} = 5 \times 10^7 (Z - 1.37)$$

$$\Rightarrow 9.39 \times 10^8 = 5 \times 10^7 (Z - 1.37) \Rightarrow 93.9 / 5 = Z - 1.37$$

$$\Rightarrow Z = 20.15 = 20$$

∴ The element is calcium.

16. K_B radiation is when the e jumps from $n = 3$ to $n = 1$ (here n is principal quantum no)

$$\Delta E = hv = Rhc (z - h)^2 \left(\frac{1}{2^2} - \frac{1}{3^2} \right)$$

$$\Rightarrow \sqrt{v} = \sqrt{\frac{9Rc}{8}} (z - h)$$

$$\therefore \sqrt{v} \propto z$$

Second method :

We can directly get value of v by`

$$hv = \text{Energy}$$

$$\Rightarrow v = \frac{\text{Energy(in kev)}}{h}$$

This we have to find out \sqrt{v} and draw the same graph as above.

17. $b = 1$

For $\propto a$ (57)

$$\sqrt{v} = a (Z - b)$$

$$\Rightarrow \sqrt{v} = a (57 - 1) = a \times 56 \quad \dots(1)$$

For Cu(29)

$$\sqrt{1.88 \times 10^{78}} = a(29 - 1) = 28 a \quad \dots(2)$$

dividing (1) and (2)

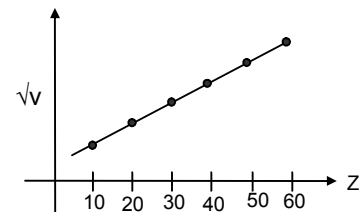

$$\sqrt{\frac{v}{1.88 \times 10^{18}}} = \frac{a \times 56}{a \times 28} = 2.$$

$$\Rightarrow v = 1.88 \times 10^{18} (2)^2 = 4 \times 1.88 \times 10^{18} = 7.52 \times 10^{18} \text{ Hz.}$$

18. $K_{\alpha} = E_K - E_L \quad \dots(1) \quad \lambda K_{\alpha} = 0.71 \text{ \AA}^{\circ}$

$K_{\beta} = E_K - E_M \quad \dots(2) \quad \lambda K_{\beta} = 0.63 \text{ \AA}^{\circ}$

$L_{\alpha} = E_L - E_M \quad \dots(3)$

Subtracting (2) from (1)

$$K_{\alpha} - K_{\beta} = E_M - E_L = -L_{\alpha}$$

$$\text{or, } L_{\alpha} = K_{\beta} - K_{\alpha} = \frac{3 \times 10^8}{0.63 \times 10^{-10}} - \frac{3 \times 10^8}{0.71 \times 10^{-10}}$$

$$= 4.761 \times 10^{18} - 4.225 \times 10^{18} = 0.536 \times 10^{18} \text{ Hz.}$$

$$\text{Again } \lambda = \frac{3 \times 10^8}{0.536 \times 10^{18}} = 5.6 \times 10^{-10} = 5.6 \text{ \AA}^{\circ}.$$

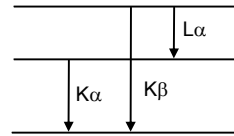

19. $E_1 = \frac{1242}{21.3 \times 10^{-3}} = 58.309 \times 10^3 \text{ eV}$

$$E_2 = \frac{1242}{141 \times 10^{-3}} = 8.8085 \times 10^3 \text{ eV}$$

$$E_3 = E_1 + E_2 \Rightarrow (58.309 + 8.809) \text{ eV} = 67.118 \times 10^3 \text{ eV}$$

$$\lambda = \frac{hc}{E_3} = \frac{1242}{67.118 \times 10^3} = 18.5 \times 10^{-3} \text{ nm} = 18.5 \text{ pm.}$$

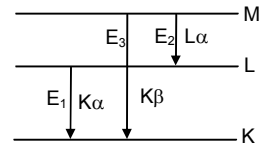

20. $E_K = 25.31 \text{ KeV, } E_L = 3.56 \text{ KeV, } E_M = 0.530 \text{ KeV}$

$$K_{\alpha} = E_K - E_L = hv$$

$$\Rightarrow v = \frac{E_K - E_L}{h} = \frac{25.31 - 3.56}{4.14 \times 10^{-15}} \times 10^3 = 5.25 \times 10^{15} \text{ Hz}$$

$$K_{\beta} = E_K - E_M = hv$$

$$\Rightarrow v = \frac{E_K - E_M}{h} = \frac{25.31 - 0.53}{4.14 \times 10^{-15}} \times 10^3 = 5.985 \times 10^{18} \text{ Hz.}$$

21. Let for, k series emission the potential required = v

\therefore Energy of electrons = ev

This amount of energy ev = energy of L shell

The maximum potential difference that can be applied without emitting any electron is 11.3 ev.

22. V = 40 KV, i = 10 mA

1% of T_{KE} (Total Kinetic Energy) = X ray

$$i = ne \quad \text{or } n = \frac{10^{-2}}{1.6 \times 10^{-19}} = 0.625 \times 10^{17} \text{ no.of electrons.}$$

$$KE \text{ of one electron} = eV = 1.6 \times 10^{-19} \times 40 \times 10^3 = 6.4 \times 10^{-15} \text{ J}$$

$$T_{KE} = 0.625 \times 6.4 \times 10^{17} \times 10^{-15} = 4 \times 10^2 \text{ J.}$$

a) Power emitted in X-ray = $4 \times 10^2 \times (-1/100) = 4w$

b) Heat produced in target per second = $400 - 4 = 396 \text{ J.}$

23. Heat produced/sec = 200 w

$$\Rightarrow \frac{neV}{t} = 200 \Rightarrow (ne/t)V = 200$$

$$\Rightarrow i = 200 / V = 10 \text{ mA.}$$

24. Given : $v = (25 \times 10^{14} \text{ Hz})(Z - 1)^2$

$$\text{Or } C/\lambda = 25 \times 10^{14} (Z - 1)^2$$

a) $\frac{3 \times 10^8}{78.9 \times 10^{-12} \times 25 \times 10^{14}} = (Z - 1)^2$

$$\text{or, } (Z - 1)^2 = 0.001520 \times 10^6 = 1520$$

$$\Rightarrow Z - 1 = 38.98 \text{ or } Z = 39.98 = 40. \text{ It is (Zr)}$$

$$b) \frac{3 \times 10^8}{146 \times 10^{-12} \times 25 \times 10^{14}} = (Z-1)^2$$

$$\text{or, } (Z-1)^2 = 0.0008219 \times 10^6$$

$$\Rightarrow Z-1 = 28.669 \text{ or } Z = 29.669 = 30. \text{ It is (Zn).}$$

$$c) \frac{3 \times 10^8}{158 \times 10^{-12} \times 25 \times 10^{14}} = (Z-1)^2$$

$$\text{or, } (Z-1)^2 = 0.0007594 \times 10^6$$

$$\Rightarrow Z-1 = 27.5589 \text{ or } Z = 28.5589 = 29. \text{ It is (Cu).}$$

$$d) \frac{3 \times 10^8}{198 \times 10^{-12} \times 25 \times 10^{14}} = (Z-1)^2$$

$$\text{or, } (Z-1)^2 = 0.000606 \times 10^6$$

$$\Rightarrow Z-1 = 24.6182 \text{ or } Z = 25.6182 = 26. \text{ It is (Fe).}$$

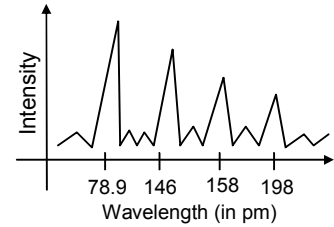

25. Here energy of photon = E
 $E = 6.4 \text{ KeV} = 6.4 \times 10^3 \text{ eV}$

$$\text{Momentum of Photon} = E/C = \frac{6.4 \times 10^3}{3 \times 10^8} = 3.41 \times 10^{-24} \text{ m/sec.}$$

According to collision theory of momentum of photon = momentum of atom

$$\therefore \text{Momentum of Atom} = P = 3.41 \times 10^{-24} \text{ m/sec}$$

$$\therefore \text{Recoil K.E. of atom} = P^2 / 2m$$

$$\Rightarrow \frac{(3.41 \times 10^{-24})^2 \text{ eV}}{(2)(9.3 \times 10^{-26} \times 1.6 \times 10^{-19})} = 3.9 \text{ eV} [1 \text{ Joule} = 1.6 \times 10^{-19} \text{ eV}]$$

26. $V_0 \rightarrow$ Stopping Potential, $\lambda \rightarrow$ Wavelength, $eV_0 = hv - hv_0$

$$eV_0 = hc/\lambda \Rightarrow V_0\lambda = hc/e$$

$V \rightarrow$ Potential difference across X-ray tube, $\lambda \rightarrow$ Cut of wavelength

$$\lambda = hc / eV \quad \text{or} \quad V\lambda = hc / e$$

Slopes are same i.e. $V_0\lambda = V\lambda$

$$\frac{hc}{e} = \frac{6.63 \times 10^{-34} \times 3 \times 10^8}{1.6 \times 10^{-19}} = 1.242 \times 10^{-6} \text{ Vm}$$

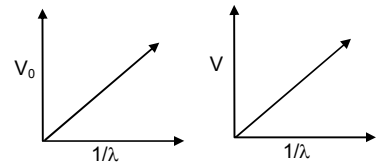

27. $\lambda = 10 \text{ pm} = 100 \times 10^{-12} \text{ m}$

$$D = 40 \text{ cm} = 40 \times 10^{-2} \text{ m}$$

$$\beta = 0.1 \text{ mm} = 0.1 \times 10^{-3} \text{ m}$$

$$\beta = \frac{\lambda D}{d}$$

$$\Rightarrow d = \frac{\lambda D}{\beta} = \frac{100 \times 10^{-12} \times 40 \times 10^{-2}}{10^{-3} \times 0.1} = 4 \times 10^{-7} \text{ m.}$$



CHAPTER - 45
SEMICONDUCTOR AND SEMICONDUCTOR DEVICES

1. $f = 1013 \text{ kg/m}^3, V = 1 \text{ m}^3$
 $m = fV = 1013 \times 1 = 1013 \text{ kg}$
 $\text{No. of atoms} = \frac{1013 \times 10^3 \times 6 \times 10^{23}}{23} = 264.26 \times 10^{26}$.
 a) Total no. of states = $2N = 2 \times 264.26 \times 10^{26} = 528.52 = 5.3 \times 10^{28} \times 10^{26}$
 b) Total no. of unoccupied states = 2.65×10^{26} .
2. In a pure semiconductor, the no. of conduction electrons = no. of holes
 Given volume = $1 \text{ cm} \times 1 \text{ cm} \times 1 \text{ mm}$
 $= 1 \times 10^{-2} \times 1 \times 10^{-2} \times 1 \times 10^{-3} = 10^{-7} \text{ m}^3$
 $\text{No. of electrons} = 6 \times 10^{19} \times 10^{-7} = 6 \times 10^{12}$.
 Hence no. of holes = 6×10^{12} .
3. $E = 0.23 \text{ eV}, K = 1.38 \times 10^{-23}$
 $KT = E$
 $\Rightarrow 1.38 \times 10^{-23} \times T = 0.23 \times 1.6 \times 10^{-19}$
 $\Rightarrow T = \frac{0.23 \times 1.6 \times 10^{-19}}{1.38 \times 10^{-23}} = \frac{0.23 \times 1.6 \times 10^4}{1.38} = 0.2676 \times 10^4 = 2670$.
4. Bandgap = $1.1 \text{ eV}, T = 300 \text{ K}$
 a) Ratio = $\frac{1.1}{KT} = \frac{1.1}{8.62 \times 10^{-5} \times 3 \times 10^2} = 42.53 = 43$
 b) $4.253' = \frac{1.1}{8.62 \times 10^{-5} \times T}$ or $T = \frac{1.1 \times 10^5}{4.253 \times 8.62} = 3000.47 \text{ K}$.
5. $2KT = \text{Energy gap between acceptor band and valency band}$
 $\Rightarrow 2 \times 1.38 \times 10^{-23} \times 300$
 $\Rightarrow E = (2 \times 1.38 \times 3) \times 10^{-21} \text{ J} = \frac{6 \times 1.38}{1.6} \times \frac{10^{-21}}{10^{-19}} \text{ eV} = \left(\frac{6 \times 1.38}{1.6} \right) \times 10^{-2} \text{ eV}$
 $= 5.175 \times 10^{-2} \text{ eV} = 51.75 \text{ meV} = 50 \text{ meV}$.
6. Given :
 Band gap = 3.2 eV ,
 $E = hc / \lambda = 1242 / \lambda = 3.2$ or $\lambda = 388.1 \text{ nm}$.
7. $\lambda = 820 \text{ nm}$
 $E = hc / \lambda = 1242 / 820 = 1.5 \text{ eV}$
8. Band Gap = $0.65 \text{ eV}, \lambda = ?$
 $E = hc / \lambda = 1242 / 0.65 = 1910.7 \times 10^{-9} \text{ m} = 1.9 \times 10^{-5} \text{ m}$.
9. Band gap = Energy need to over come the gap
 $\frac{hc}{\lambda} = \frac{1242 \text{ eV} - \text{nm}}{620 \text{ nm}} = 2.0 \text{ eV}$.
10. Given $n = e^{-\Delta E / 2KT}, \Delta E = \text{Diamond} \rightarrow 6 \text{ eV}; \Delta E \text{ Si} \rightarrow 1.1 \text{ eV}$
 Now, $n_1 = e^{-\Delta E_1 / 2KT} = e^{\frac{-6}{2 \times 300 \times 8.62 \times 10^{-5}}}$
 $n_2 = e^{-\Delta E_2 / 2KT} = e^{\frac{-1.1}{2 \times 300 \times 8.62 \times 10^{-5}}}$
 $\frac{n_1}{n_2} = \frac{4.14772 \times 10^{-51}}{5.7978 \times 10^{-10}} = 7.15 \times 10^{-42}$.

Due to more ΔE , the conduction electrons per cubic metre in diamond is almost zero.

11. $\sigma = T^{3/2} e^{-\Delta E/2KT}$ at 4°K

$$\sigma = 4^{3/2} = e^{\frac{-0.74}{2 \times 8.62 \times 10^{-5} \times 4}} = 8 \times e^{-1073.08}$$

At 300 K,

$$\sigma = 300^{3/2} e^{\frac{-0.67}{2 \times 8.62 \times 10^{-5} \times 300}} = \frac{3 \times 1730}{8} e^{-12.95}$$

$$\text{Ratio} = \frac{8 \times e^{-1073.08}}{[(3 \times 1730)/8] \times e^{-12.95}} = \frac{64}{3 \times 1730} e^{-1060.13}$$

12. Total no. of charge carriers initially = $2 \times 7 \times 10^{15} = 14 \times 10^{15}$ /Cubic meter

Finally the total no. of charge carriers = $14 \times 10^{17} / \text{m}^3$

We know :

The product of the concentrations of holes and conduction electrons remains, almost the same.

Let x be the no. of holes.

$$\text{So, } (7 \times 10^{15}) \times (7 \times 10^{15}) = x \times (14 \times 10^{17} - x)$$

$$\Rightarrow 14x \times 10^{17} - x^2 = 79 \times 10^{30}$$

$$\Rightarrow x^2 - 14x \times 10^{17} - 49 \times 10^{30} = 0$$

$$x = \frac{14 \times 10^{17} \pm 14^2 \times \sqrt{10^{34} + 4 \times 49 \times 10^{30}}}{2} = 14.00035 \times 10^{17}$$

= Increased in no. of holes or the no. of atoms of Boron added.

$$\Rightarrow 1 \text{ atom of Boron is added per } \frac{5 \times 10^{28}}{1386.035 \times 10^{15}} = 3.607 \times 10^{-3} \times 10^{13} = 3.607 \times 10^{10}$$

13. (No. of holes) (No. of conduction electrons) = constant.

At first :

$$\text{No. of conduction electrons} = 6 \times 10^{19}$$

$$\text{No. of holes} = 6 \times 10^{19}$$

After doping

$$\text{No. of conduction electrons} = 2 \times 10^{23}$$

$$\text{No. of holes} = x.$$

$$(6 \times 10^{19})(6 \times 10^{19}) = (2 \times 10^{23})x$$

$$\Rightarrow \frac{6 \times 6 \times 10^{19+19}}{2 \times 10^{23}} = x$$

$$\Rightarrow x = 18 \times 10^{15} = 1.8 \times 10^{16}$$

14. $\sigma = \sigma_0 e^{-\Delta E/2KT}$

$$\Delta E = 0.650 \text{ eV, } T = 300 \text{ K}$$

$$\text{According to question, } K = 8.62 \times 10^{-5} \text{ eV}$$

$$\sigma_0 e^{-\Delta E/2KT} = 2 \times \sigma_0 e^{\frac{-\Delta E}{2 \times K \times 300}}$$

$$\Rightarrow e^{\frac{-0.65}{2 \times 8.62 \times 10^{-5} \times T}} = 6.96561 \times 10^{-5}$$

Taking in on both sides,

$$\text{We get, } \frac{-0.65}{2 \times 8.62 \times 10^{-5} \times T'} = -11.874525$$

$$\Rightarrow \frac{1}{T'} = \frac{11.874525 \times 2 \times 8.62 \times 10^{-5}}{0.65}$$

$$\Rightarrow T' = 317.51178 = 318 \text{ K.}$$

15. Given band gap = 1 eV
 Net band gap after doping = $(1 - 10^{-3})\text{eV} = 0.999 \text{ eV}$
 According to the question, $KT_1 = 0.999/50$
 $\Rightarrow T_1 = 231.78 = 231.8$
 For the maximum limit $KT_2 = 2 \times 0.999$
 $\Rightarrow T_2 = \frac{2 \times 1 \times 10^{-3}}{8.62 \times 10^{-5}} = \frac{2}{8.62} \times 10^2 = 23.2$
 Temperature range is (23.2 – 231.8).
16. Depletion region 'd' = 400 nm = $4 \times 10^{-7} \text{ m}$
 Electric field $E = 5 \times 10^5 \text{ V/m}$
 a) Potential barrier $V = E \times d = 0.2 \text{ V}$
 b) Kinetic energy required = Potential barrier $\times e = 0.2 \text{ eV}$ [Where e = Charge of electron]
17. Potential barrier = 0.2 Volt
 a) K.E. = (Potential difference) $\times e = 0.2 \text{ eV}$ (in unbiased condⁿ)
 b) In forward biasing
 $KE + Ve = 0.2e$
 $\Rightarrow KE = 0.2e - 0.1e = 0.1e$
 c) In reverse biasing
 $KE - Ve = 0.2e$
 $\Rightarrow KE = 0.2e + 0.1e = 0.3e$
18. Potential barrier 'd' = 250 meV
 Initial KE of hole = 300 meV
 We know : KE of the hole decreases when the junction is forward biased and increases when reverse biased in the given 'Pn' diode.
 So,
 a) Final KE = $(300 - 250) \text{ meV} = 50 \text{ meV}$
 b) Initial KE = $(300 + 250) \text{ meV} = 550 \text{ meV}$
19. $i_1 = 25 \mu\text{A}$, $V = 200 \text{ mV}$, $i_2 = 75 \mu\text{A}$
 a) When in unbiased condition drift current = diffusion current
 \therefore Diffusion current = $25 \mu\text{A}$
 b) On reverse biasing the diffusion current becomes 'O'.
 c) On forward biasing the actual current be x.
 $x - \text{Drift current} = \text{Forward biasing current}$
 $\Rightarrow x - 25 \mu\text{A} = 75 \mu\text{A}$
 $\Rightarrow x = (75 + 25) \mu\text{A} = 100 \mu\text{A}$
20. Drift current = $20 \mu\text{A} = 20 \times 10^{-6} \text{ A}$.
 Both holes and electrons are moving
 So, no. of electrons = $\frac{20 \times 10^{-6}}{2 \times 1.6 \times 10^{-19}} = 6.25 \times 10^{13}$.
21. a) $e^{aV/KT} = 100$
 $\Rightarrow \frac{V}{8.62 \times 10^{-5} \times 300} = 100$
 $\Rightarrow \frac{V}{8.62 \times 10^{-5} \times 300} = 4.605 \Rightarrow V = 4.605 \times 8.62 \times 3 \times 10^{-3} = 119.08 \times 10^{-3}$
 $R = \frac{V}{I} = \frac{V}{I_0(e^{eV/KT} - 1)} = \frac{119.08 \times 10^{-3}}{10 \times 10^{-6} \times (100 - 1)} = \frac{119.08 \times 10^{-3}}{99 \times 10^{-5}} = 1.2 \times 10^2$
 $V_0 = I_0 R$
 $\Rightarrow 10 \times 10^{-6} \times 1.2 \times 10^2 = 1.2 \times 10^{-3} = 0.0012 \text{ V}$.

c) $0.2 = \frac{KT}{e i_0} e^{-eV/KT}$

$K = 8.62 \times 10^{-5} \text{ eV/K}, T = 300 \text{ K}$

$i_0 = 10 \times 10^{-5} \text{ A}$

Substituting the values in the equation and solving

We get $V = 0.25$

22. a) $i_0 = 20 \times 10^{-6} \text{ A}, T = 300 \text{ K}, V = 300 \text{ mV}$

$i = i_0 e^{\frac{eV}{KT} - 1} = 20 \times 10^{-6} (e^{\frac{100}{8.62}} - 1) = 2.18 \text{ A} = 2 \text{ A}$

b) $4 = 20 \times 10^{-6} (e^{\frac{V}{8.62 \times 3 \times 10^{-2}} - 1}) \Rightarrow e^{\frac{V \times 10^3}{8.62 \times 3}} - 1 = \frac{4 \times 10^6}{20}$

$\Rightarrow e^{\frac{V \times 10^3}{8.62 \times 3}} = 200001 \Rightarrow \frac{V \times 10^3}{8.62 \times 3} = 12.2060$

$\Rightarrow V = 315 \text{ mV} = 318 \text{ mV}$

23. a) Current in the circuit = Drift current

(Since, the diode is reverse biased = $20 \mu\text{A}$)

b) Voltage across the diode = $5 - (20 \times 20 \times 10^{-6})$
 $= 5 - (4 \times 10^{-4}) = 5 \text{ V}$

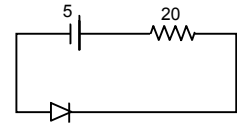

24. From the figure :

According to wheat stone bridge principle, there is no current through the diode.

Hence net resistance of the circuit is $\frac{40}{2} = 20 \Omega$.

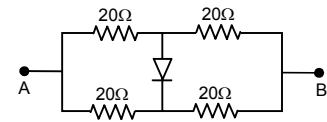

25. a) Since both the diodes are forward biased net resistance = 0

$i = \frac{2V}{2\Omega} = 1 \text{ A}$

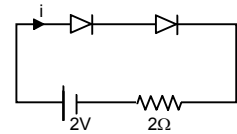

b) One of the diodes is forward biased and other is reverse bias.

Thus the resistance of one becomes ∞ .

$i = \frac{2}{2 + \infty} = 0 \text{ A}$

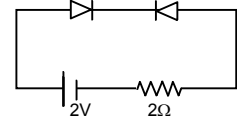

Both are forward biased.

Thus the resistance is 0.

$i = \frac{2}{2} = 1 \text{ A}$

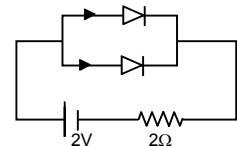

One is forward biased and other is reverse biased.

Thus the current passes through the forward biased diode.

$\therefore i = \frac{2}{2} = 1 \text{ A}$

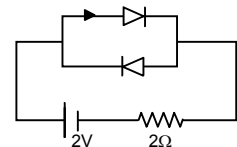

26. The diode is reverse biased. Hence the resistance is infinite. So, current through A_1 is zero.

For A_2 , current = $\frac{2}{10} = 0.2 \text{ Amp}$.

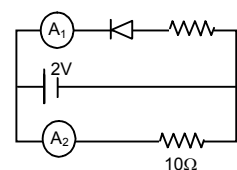

27. Both diodes are forward biased. Thus the net diode resistance is 0.

$$i = \frac{5}{(10+10)/10 \cdot 10} = \frac{5}{5} = 1 \text{ A.}$$

One diode is forward biased and other is reverse biased.

Current passes through the forward biased diode only.

$$i = \frac{V}{R_{\text{net}}} = \frac{5}{10+0} = 1/2 = 0.5 \text{ A.}$$

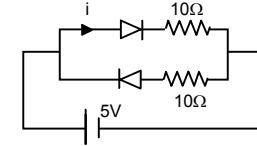
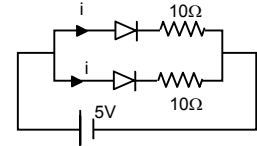

28. a) When $R = 12 \Omega$

The wire EF becomes ineffective due to the net (-)ve voltage.

Hence, current through $R = 10/24 = 0.4166 = 0.42 \text{ A.}$

b) Similarly for $R = 48 \Omega.$

$$i = \frac{10}{(48+12)} = 10/60 = 0.16 \text{ A.}$$

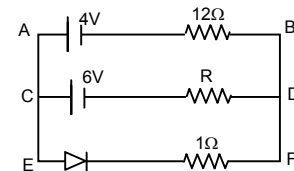

29.

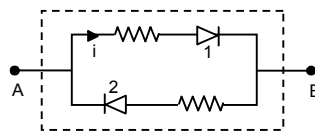
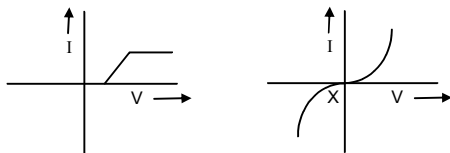
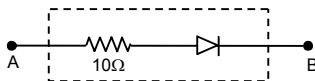

Since the diode 2 is reverse biased no current will pass through it.

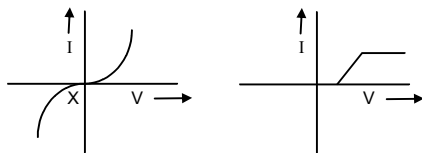

30. Let the potentials at A and B be V_A and V_B respectively.

i) If $V_A > V_B$

Then current flows from A to B and the diode is in forward biased.

Eq. Resistance = $10/2 = 5 \Omega.$

ii) If $V_A < V_B$

Then current flows from B to A and the diode is reverse biased.

Hence Eq. Resistance = $10 \Omega.$

31. $\delta I_b = 80 \mu\text{A} - 30 \mu\text{A} = 50 \mu\text{A} = 50 \times 10^{-6} \text{ A}$

$\delta I_c = 3.5 \text{ mA} - 1 \text{ mA} = 2.5 \text{ mA} = 2.5 \times 10^{-3} \text{ A}$

$$\beta = \left(\frac{\delta I_c}{\delta I_b} \right) V_{ce} = \text{constant}$$

$$\Rightarrow \frac{2.5 \times 10^{-3}}{50 \times 10^{-6}} = \frac{2500}{50} = 50.$$

Current gain = 50.

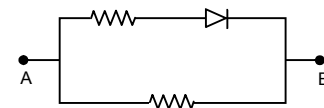

32. $\beta = 50, \delta I_b = 50 \mu\text{A},$

$$V_0 = \beta \times R_G = 50 \times 2/0.5 = 200.$$

a) $V_G = V_0/V_1 = \frac{V_0}{\delta I_b \times R_i} = \frac{200}{50 \times 10^{-6} \times 5 \times 10^2} = 8000 \text{ V}.$

b) $\delta V_i = \delta I_b \times R_i = 50 \times 10^{-6} \times 5 \times 10^2 = 0.00025 \text{ V} = 25 \text{ mV}.$

c) Power gain = $\beta^2 \times R_G = \beta^2 \times \frac{R_0}{R_i} = 2500 \times \frac{2}{0.5} = 10^4.$

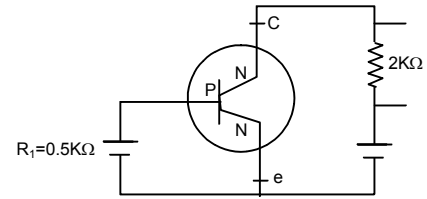

33. $X = \overline{ABC} + \overline{BCA} + \overline{CAB}$

a) $A = 1, B = 0, C = 1$

$$X = 1.$$

b) $A = B = C = 1$

$$X = 0.$$

34. For $\overline{ABC} + \overline{BCA}$

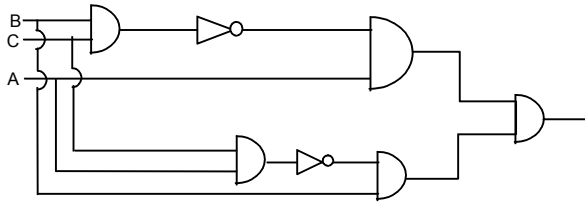

35. LHS = $AB \times \overline{AB} = X + \overline{X}$ [$X = AB$]

If $X = 0, \overline{X} = 1$

If $\overline{X} = 0, X = 1$

$$\Rightarrow 1 + 0 \text{ or } 0 + 1 = 1$$

$$\Rightarrow \text{RHS} = 1 \text{ (Proved)}$$



THE NUCLEUS CHAPTER - 46

- $M = Am_p$, $f = M/V$, $m_p = 1.007276 \text{ u}$
 $R = R_0 A^{1/3} = 1.1 \times 10^{-15} A^{1/3}$, $u = 1.6605402 \times 10^{-27} \text{ kg}$

$$= \frac{A \times 1.007276 \times 1.6605402 \times 10^{-27}}{4/3 \times 3.14 \times R^3} = 0.300159 \times 10^{18} = 3 \times 10^{17} \text{ kg/m}^3$$
 'f' in CGS = Specific gravity = 3×10^{14} .
- $f = \frac{M}{V} \Rightarrow V = \frac{M}{f} = \frac{4 \times 10^{30}}{2.4 \times 10^{17}} = \frac{1}{0.6} \times 10^{13} = \frac{1}{6} \times 10^{14}$
 $V = 4/3 \pi R^3$
 $\Rightarrow \frac{1}{6} \times 10^{14} = 4/3 \pi \times R^3 \Rightarrow R^3 = \frac{1}{6} \times \frac{3}{4} \times \frac{1}{\pi} \times 10^{14}$
 $\Rightarrow R^3 = \frac{1}{8} \times \frac{100}{\pi} \times 10^{12}$
 $\therefore R = \frac{1}{2} \times 10^4 \times 3.17 = 1.585 \times 10^4 \text{ m} = 15 \text{ km}$.
- Let the mass of ' α ' particle be xu .
' α ' particle contains 2 protons and 2 neutrons.
 \therefore Binding energy = $(2 \times 1.007825 \text{ u} + 2 \times 1.00866 \text{ u} - xu)C^2 = 28.2 \text{ MeV}$ (given).
 $\therefore x = 4.0016 \text{ u}$.
- $\text{Li}^7 + p \rightarrow \text{I} + \alpha + E$; $\text{Li}^7 = 7.016 \text{ u}$
 $\alpha = {}^4\text{He} = 4.0026 \text{ u}$; $p = 1.007276 \text{ u}$
 $E = \text{Li}^7 + p - 2\alpha = (7.016 + 1.007276) \text{ u} - (2 \times 4.0026) \text{ u} = 0.018076 \text{ u}$.
 $\Rightarrow 0.018076 \times 931 = 16.828 = 16.83 \text{ MeV}$.
- $B = (Zm_p + Nm_n - M)C^2$
 $Z = 79$; $N = 118$; $m_p = 1.007276 \text{ u}$; $M = 196.96 \text{ u}$; $m_n = 1.008665 \text{ u}$
 $B = [(79 \times 1.007276 + 118 \times 1.008665) \text{ u} - M]c^2$
 $= 198.597274 \times 931 - 196.96 \times 931 = 1524.302094$
 so, Binding Energy per nucleon = $1524.3 / 197 = 7.737$.
- a) $U^{238} {}_2\text{He}^4 + \text{Th}^{234}$
 $E = [M_U - (N_{HC} + M_{Th})]u = 238.0508 - (234.04363 + 4.00260)u = 4.25487 \text{ MeV} = 4.255 \text{ MeV}$.
 b) $E = U^{238} - [\text{Th}^{234} + 2n'_0 + 2p'_1]$
 $= \{238.0508 - [234.64363 + 2(1.008665) + 2(1.007276)]\}u$
 $= 0.024712 \text{ u} = 23.0068 = 23.007 \text{ MeV}$.
- ${}^{223}\text{Ra} = 223.018 \text{ u}$; ${}^{209}\text{Pb} = 208.981 \text{ u}$; ${}^{14}\text{C} = 14.003 \text{ u}$.
 ${}^{223}\text{Ra} \rightarrow {}^{209}\text{Pb} + {}^{14}\text{C}$
 $\Delta m = \text{mass } {}^{223}\text{Ra} - \text{mass } ({}^{209}\text{Pb} + {}^{14}\text{C})$
 $\Rightarrow = 223.018 - (208.981 + 14.003) = 0.034$.
 Energy = $\Delta M \times u = 0.034 \times 931 = 31.65 \text{ Me}$.
- $E_{Z,N} \rightarrow E_{Z-1, N+1} \Rightarrow E_{Z,N} \rightarrow E_{Z-1, N} + {}^1_1\text{H}^1$ [As hydrogen has no neutrons but protons only]
 $\Delta E = (M_{Z-1, N} + N_H - M_{Z,N})c^2$
- $E_2N = E_{Z,N-1} + {}^1_0n$.
 Energy released = (Initial Mass of nucleus - Final mass of nucleus) $c^2 = (M_{Z,N-1} + M_0 - M_{Z,N})c^2$.
- $\text{P}^{32} \rightarrow \text{S}^{32} + {}^0_{-1}\bar{\nu} + {}^0_{+1}\beta$
 Energy of antineutrino and β -particle
 $= (31.974 - 31.972)u = 0.002 \text{ u} = 0.002 \times 931 = 1.862 \text{ MeV} = 1.86$.
- $\text{In} \rightarrow \text{P} + e^-$
 We know : Half life = $0.6931 / \lambda$ (Where λ = decay constant).
 Or $\lambda = 0.6931 / 14 \times 60 = 8.25 \times 10^{-4} \text{ S}$ [As half life = 14 min = 14×60 sec].
 Energy = $[M_n - (M_p + M_e)]u = [(M_{nu} - M_{pu}) - M_{pe}]c^2 = [0.00189 \text{ u} - 511 \text{ KeV}/c^2]$
 $= [1293159 \text{ eV}/c^2 - 511000 \text{ eV}/c^2]c^2 = 782159 \text{ eV} = 782 \text{ KeV}$.

12. ${}_{58}^{226}\text{Ra} \rightarrow {}_2^4\alpha + {}_{26}^{222}\text{Rn}$
 ${}_{8}^{19}\text{O} \rightarrow {}_{9}^{19}\text{F} + {}_n^0\beta + {}_0^0\bar{\nu}$
 ${}_{25}^{13}\text{Al} \rightarrow {}_{12}^{25}\text{MG} + {}_{-1}^0\text{e} + {}_0^0\bar{\nu}$
13. ${}^{64}\text{Cu} \rightarrow {}^{64}\text{Ni} + \text{e}^- + \nu$
 Emission of neutrino is along with a positron emission.
 a) Energy of positron = 0.650 MeV.
 Energy of Neutrino = 0.650 – KE of given positron = 0.650 – 0.150 = 0.5 MeV = 500 KeV.
 b) Momentum of Neutrino = $\frac{500 \times 1.6 \times 10^{-19}}{3 \times 10^8} \times 10^3 \text{ J} = 2.67 \times 10^{-22} \text{ kg m/s.}$
14. a) ${}_{19}^{40}\text{K} \rightarrow {}_{20}^{40}\text{Ca} + {}_{-1}^0\text{e} + {}_0^0\bar{\nu}$
 ${}_{19}^{40}\text{K} \rightarrow {}_{18}^{40}\text{Ar} + {}_{-1}^0\text{e} + {}_0^0\bar{\nu}$
 ${}_{19}^{40}\text{K} + {}_{-1}^0\text{e} \rightarrow {}_{18}^{40}\text{Ar}$
 ${}_{19}^{40}\text{K} \rightarrow {}_{20}^{40}\text{Ca} + {}_{-1}^0\text{e} + {}_0^0\bar{\nu}$.
 b) $Q = [\text{Mass of reactants} - \text{Mass of products}]c^2$
 $= [39.964\text{u} - 39.9626\text{u}] = [39.964\text{u} - 39.9626\text{u}]c^2 = (39.964 - 39.9626) 931 \text{ MeV} = 1.3034 \text{ MeV.}$
 ${}_{19}^{40}\text{K} \rightarrow {}_{18}^{40}\text{Ar} + {}_{-1}^0\text{e} + {}_0^0\bar{\nu}$
 $Q = (39.9640 - 39.9624)uc^2 = 1.4890 = 1.49 \text{ MeV.}$
 ${}_{19}^{40}\text{K} + {}_{-1}^0\text{e} \rightarrow {}_{18}^{40}\text{Ar}$
 $Q_{\text{value}} = (39.964 - 39.9624)uc^2$.
15. ${}_{3}^6\text{Li} + \text{n} \rightarrow {}_{3}^7\text{Li} ; {}_{3}^7\text{Li} + \text{r} \rightarrow {}_{3}^8\text{Li}$
 ${}_{3}^8\text{Li} \rightarrow {}_{4}^8\text{Be} + \text{e}^- + \nu^-$
 ${}_{4}^8\text{Be} \rightarrow {}_{2}^4\text{He} + {}_{2}^4\text{He}$
16. ${}^{\text{C}} \rightarrow {}^{\text{B}} + \beta^+ + \nu$
 mass of C = 11.014u ; mass of B = 11.0093u
 Energy liberated = (11.014 – 11.0093)u = 29.5127 MeV.
 For maximum K.E. of the positron energy of ν may be assumed as 0.
 \therefore Maximum K.E. of the positron is 29.5127 MeV.
17. Mass ${}^{238}\text{Th} = 228.028726 \text{ u} ; {}^{224}\text{Ra} = 224.020196 \text{ u} ; \alpha = {}_2^4\text{He} \rightarrow 4.00260\text{u}$
 ${}^{238}\text{Th} \rightarrow {}^{224}\text{Ra}^* + \alpha$
 ${}^{224}\text{Ra}^* \rightarrow {}^{224}\text{Ra} + \nu(217 \text{ Kev})$
 Now, Mass of ${}^{224}\text{Ra}^* = 224.020196 \times 931 + 0.217 \text{ MeV} = 208563.0195 \text{ MeV.}$
 KE of $\alpha = E({}^{226}\text{Th}) - E({}^{224}\text{Ra}^* + \alpha)$
 $= 228.028726 \times 931 - [208563.0195 + 4.00260 \times 931] = 5.30383 \text{ MeV} = 5.304 \text{ MeV.}$
18. ${}^{12}\text{N} \rightarrow {}^{12}\text{C}^* + \text{e}^+ + \nu$
 ${}^{12}\text{C}^* \rightarrow {}^{12}\text{C} + \nu(4.43 \text{ MeV})$
 Net reaction : ${}^{12}\text{N} \rightarrow {}^{12}\text{C} + \text{e}^+ + \nu + \nu(4.43 \text{ MeV})$
 Energy of $(\text{e}^+ + \nu) = N^{12} - (C^{12} + \nu)$
 $= 12.018613\text{u} - (12)\text{u} - 4.43 = 0.018613 \text{ u} - 4.43 = 17.328 - 4.43 = 12.89 \text{ MeV.}$
 Maximum energy of electron (assuming 0 energy for ν) = 12.89 MeV.
19. a) $t_{1/2} = 0.693 / \lambda$ [$\lambda \rightarrow$ Decay constant]
 $\Rightarrow t_{1/2} = 3820 \text{ sec} = 64 \text{ min.}$
 b) Average life = $t_{1/2} / 0.693 = 92 \text{ min.}$
 c) $0.75 = 1 \text{ e}^{-\lambda t} \Rightarrow \ln 0.75 = -\lambda t \Rightarrow t = \ln 0.75 / -0.00018 = 1598.23 \text{ sec.}$
20. a) 198 grams of Ag contains $\rightarrow N_0$ atoms.
 $1 \mu\text{g of Ag contains} \rightarrow N_0/198 \times 1 \mu\text{g} = \frac{6 \times 10^{23} \times 1 \times 10^{-6}}{198} \text{ atoms}$

- $$\text{Activity} = \lambda N = \frac{0.693}{t_{1/2}} \times N = \frac{0.693 \times 6 \times 10^{17}}{198 \times 2.7} \text{ disintegrations/day.}$$
- $$= \frac{0.693 \times 6 \times 10^{17}}{198 \times 2.7 \times 3600 \times 24} \text{ disintegration/sec} = \frac{0.693 \times 6 \times 10^{17}}{198 \times 2.7 \times 36 \times 24 \times 3.7 \times 10^{10}} \text{ curie} = 0.244 \text{ Curie.}$$
- b) $A = \frac{A_0}{2^{t/t_{1/2}}} = \frac{0.244}{2 \times \frac{7}{2.7}} = 0.0405 = 0.040 \text{ Curie.}$
21. $t_{1/2} = 8.0 \text{ days}$; $A_0 = 20 \mu \text{ Ci}$
 a) $t = 4.0 \text{ days}$; $\lambda = 0.693/8$
 $A = A_0 e^{-\lambda t} = 20 \times 10^{-6} \times e^{-(0.693/8) \times 4} = 1.41 \times 10^{-5} \text{ Ci} = 14 \mu \text{ Ci}$
 b) $\lambda = \frac{0.693}{8 \times 24 \times 3600} = 1.0026 \times 10^{-6}.$
22. $\lambda = 4.9 \times 10^{-18} \text{ s}^{-1}$
 a) Avg. life of $^{238}\text{U} = \frac{1}{\lambda} = \frac{1}{4.9 \times 10^{-18}} = \frac{1}{4.9} \times 10^{18} \text{ sec.}$
 $= 6.47 \times 10^3 \text{ years.}$
 b) Half life of uranium $= \frac{0.693}{\lambda} = \frac{0.693}{4.9 \times 10^{-18}} = 4.5 \times 10^9 \text{ years.}$
 c) $A = \frac{A_0}{2^{t/t_{1/2}}} \Rightarrow \frac{A_0}{2^{t/t_{1/2}}} = \frac{A_0}{A} = 2^2 = 4.$
23. $A = 200$, $A_0 = 500$, $t = 50 \text{ min}$
 $A = A_0 e^{-\lambda t}$ or $200 = 500 \times e^{-50 \times 60 \times \lambda}$
 $\Rightarrow \lambda = 3.05 \times 10^{-4} \text{ s.}$
 b) $t_{1/2} = \frac{0.693}{\lambda} = \frac{0.693}{0.000305} = 2272.13 \text{ sec} = 38 \text{ min.}$
24. $A_0 = 4 \times 10^5 \text{ disintegration / sec}$
 $A' = 1 \times 10^6 \text{ dis/sec}$; $t = 20 \text{ hours.}$
 $A' = \frac{A_0}{2^{t/t_{1/2}}} \Rightarrow 2^{t/t_{1/2}} = \frac{A_0}{A'} \Rightarrow 2^{t/t_{1/2}} = 4$
 $\Rightarrow t/t_{1/2} = 2 \Rightarrow t^{1/2} = t/2 = 20 \text{ hours} / 2 = 10 \text{ hours.}$
 $A'' = \frac{A_0}{2^{t/t_{1/2}}} \Rightarrow A'' = \frac{4 \times 10^6}{2^{100/10}} = 0.00390625 \times 10^6 = 3.9 \times 10^3 \text{ disintegrations/sec.}$
25. $t_{1/2} = 1602 \text{ Y}$; $Ra = 226 \text{ g/mole}$; $Cl = 35.5 \text{ g/mole.}$
 1 mole $\text{RaCl}_2 = 226 + 71 = 297 \text{ g}$
 $297 \text{ g} = 1 \text{ mole of Ra.}$
 $0.1 \text{ g} = \frac{1}{297} \times 0.1 \text{ mole of Ra} = \frac{0.1 \times 6.023 \times 10^{23}}{297} = 0.02027 \times 10^{22}$
 $\lambda = 0.693 / t_{1/2} = 1.371 \times 10^{-11}.$
 $\text{Activity} = \lambda N = 1.371 \times 10^{-11} \times 2.027 \times 10^{20} = 2.779 \times 10^9 = 2.8 \times 10^9 \text{ disintegrations/second.}$
26. $t_{1/2} = 10 \text{ hours}$, $A_0 = 1 \text{ ci}$
 Activity after 9 hours $= A_0 e^{-\lambda t} = 1 \times e^{\frac{-0.693}{10} \times 9} = 0.5359 = 0.536 \text{ Ci.}$
 No. of atoms left after 9th hour, $A_9 = \lambda N_9$
 $\Rightarrow N_9 = \frac{A_9}{\lambda} = \frac{0.536 \times 10 \times 3.7 \times 10^{10} \times 3600}{0.693} = 28.6176 \times 10^{10} \times 3600 = 103.023 \times 10^{13}.$
 Activity after 10 hours $= A_0 e^{-\lambda t} = 1 \times e^{\frac{-0.693}{10} \times 10} = 0.5 \text{ Ci.}$
 No. of atoms left after 10th hour
 $A_{10} = \lambda N_{10}$

$$\Rightarrow N_{10} = \frac{A_{10}}{\lambda} = \frac{0.5 \times 3.7 \times 10^{10} \times 3600}{0.693/10} = 26.37 \times 10^{10} \times 3600 = 96.103 \times 10^{13}$$

$$\text{No. of disintegrations} = (103.023 - 96.103) \times 10^{13} = 6.92 \times 10^{13}$$

27. $t_{1/2} = 14.3$ days ; $t = 30$ days = 1 month

As, the selling rate is decided by the activity, hence $A_0 = 800$ disintegration/sec.

$$\text{We know, } A = A_0 e^{-\lambda t} \quad [\lambda = 0.693/14.3]$$

$$A = 800 \times 0.233669 = 186.935 = 187 \text{ rupees.}$$

28. According to the question, the emission rate of γ rays will drop to half when the β^+ decays to half of its original amount. And for this the sample would take 270 days.

\therefore The required time is 270 days.

29. a) $P \rightarrow n + e^+ + \nu$ Hence it is a β^+ decay.

b) Let the total no. of atoms be $100 N_0$.

	Carbon	Boron
Initially	$90 N_0$	$10 N_0$
Finally	$10 N_0$	$90 N_0$

$$\text{Now, } 10 N_0 = 90 N_0 e^{-\lambda t} \Rightarrow 1/9 = e^{-\frac{0.693}{20.3} \times t} \quad [\text{because } t_{1/2} = 20.3 \text{ min}]$$

$$\Rightarrow \ln \frac{1}{9} = \frac{-0.693}{20.3} t \Rightarrow t = \frac{2.1972 \times 20.3}{0.693} = 64.36 = 64 \text{ min.}$$

30. $N = 4 \times 10^{23}$; $t_{1/2} = 12.3$ years.

$$\text{a) Activity} = \frac{dN}{dt} = \lambda n = \frac{0.693}{t_{1/2}} N = \frac{0.693}{12.3} \times 4 \times 10^{23} \text{ dis/year.}$$

$$= 7.146 \times 10^{14} \text{ dis/sec.}$$

$$\text{b) } \frac{dN}{dt} = 7.146 \times 10^{14}$$

$$\text{No. of decays in next 10 hours} = 7.146 \times 10^{14} \times 10 \times 3600 = 257.256 \times 10^{17} = 2.57 \times 10^{19}$$

$$\text{c) } N = N_0 e^{-\lambda t} = 4 \times 10^{23} \times e^{-\frac{0.693}{12.3} \times 6.16} = 2.82 \times 10^{23} = \text{No. of atoms remained}$$

$$\text{No. of atoms disintegrated} = (4 - 2.82) \times 10^{23} = 1.18 \times 10^{23}$$

31. Counts received per $\text{cm}^2 = 50000$ Counts/sec.

$$N = N_0 \text{ of active nucleic} = 6 \times 10^{16}$$

$$\text{Total counts radiated from the source} = \text{Total surface area} \times 50000 \text{ counts/cm}^2$$

$$= 4 \times 3.14 \times 1 \times 10^4 \times 5 \times 10^4 = 6.28 \times 10^9 \text{ Counts} = dN/dt$$

$$\text{We know, } \frac{dN}{dt} = \lambda N$$

$$\text{Or } \lambda = \frac{6.28 \times 10^9}{6 \times 10^{16}} = 1.0467 \times 10^{-7} = 1.05 \times 10^{-7} \text{ s}^{-1}$$

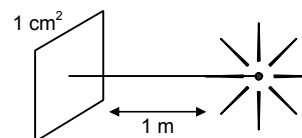

32. Half life period can be a single for all the process. It is the time taken for 1/2 of the uranium to convert to lead.

$$\text{No. of atoms of } U^{238} = \frac{6 \times 10^{23} \times 2 \times 10^{-3}}{238} = \frac{12}{238} \times 10^{20} = 0.05042 \times 10^{20}$$

$$\text{No. of atoms in Pb} = \frac{6 \times 10^{23} \times 0.6 \times 10^{-3}}{206} = \frac{3.6}{206} \times 10^{20}$$

$$\text{Initially total no. of uranium atoms} = \left(\frac{12}{235} + \frac{3.6}{206} \right) \times 10^{20} = 0.06789$$

$$N = N_0 e^{-\lambda t} \Rightarrow N = N_0 e^{-t/t_{1/2}} \Rightarrow 0.05042 = 0.06789 e^{-\frac{0.693}{4.47 \times 10^9} t}$$

$$\Rightarrow \log \left(\frac{0.05042}{0.06789} \right) = \frac{-0.693 t}{4.47 \times 10^9}$$

$$\Rightarrow t = 1.92 \times 10^9 \text{ years.}$$

33. $A_0 = 15.3$; $A = 12.3$; $t_{1/2} = 5730$ year

$$\lambda = \frac{0.6931}{T_{1/2}} = \frac{0.6931}{5730} \text{ yr}^{-1}$$

Let the time passed be t ,

$$\text{We know } A = A_0 e^{-\lambda t} = \frac{0.6931}{5730} \times t \Rightarrow 12.3 = 15.3 \times e^{-\lambda t}$$

$$\Rightarrow t = 1804.3 \text{ years.}$$

34. The activity when the bottle was manufactured = A_0

$$\text{Activity after 8 years} = A_0 e^{-\frac{0.693}{12.5} \times 8}$$

Let the time of the mountaineering = t years from the present

$$A = A_0 e^{-\frac{0.693}{12.5} \times t}$$
 ; $A = \text{Activity of the bottle found on the mountain.}$

$$A = (\text{Activity of the bottle manufactured 8 years before}) \times 1.5\%$$

$$\Rightarrow A_0 e^{-\frac{0.693}{12.5} \times t} = A_0 e^{-\frac{0.693}{12.5} \times 8} \times 0.015$$

$$\Rightarrow \frac{-0.693}{12.5} t = \frac{-0.693 \times 8}{12.5} + \ln[0.015]$$

$$\Rightarrow 0.05544 t = 0.44352 + 4.1997 \Rightarrow t = 83.75 \text{ years.}$$

35. a) Here we should take R_0 at time is $t_0 = 30 \times 10^9 \text{ s}^{-1}$

$$\text{i) } \ln(R_0/R_1) = \ln\left(\frac{30 \times 10^9}{30 \times 10^9}\right) = 0$$

$$\text{ii) } \ln(R_0/R_2) = \ln\left(\frac{30 \times 10^9}{16 \times 10^9}\right) = 0.63$$

$$\text{iii) } \ln(R_0/R_3) = \ln\left(\frac{30 \times 10^9}{8 \times 10^9}\right) = 1.35$$

$$\text{iv) } \ln(R_0/R_4) = \ln\left(\frac{30 \times 10^9}{3.8 \times 10^9}\right) = 2.06$$

$$\text{v) } \ln(R_0/R_5) = \ln\left(\frac{30 \times 10^9}{2 \times 10^9}\right) = 2.7$$

b) \therefore The decay constant $\lambda = 0.028 \text{ min}^{-1}$

c) \therefore The half life period = $t_{1/2}$.

$$t_{1/2} = \frac{0.693}{\lambda} = \frac{0.693}{0.028} = 25 \text{ min.}$$

36. Given : Half life period $t_{1/2} = 1.30 \times 10^9$ year , $A = 160 \text{ count/s} = 1.30 \times 10^9 \times 365 \times 86400$

$$\therefore A = \lambda N \Rightarrow 160 = \frac{0.693}{t_{1/2}} N$$

$$\Rightarrow N = \frac{160 \times 1.30 \times 365 \times 86400 \times 10^9}{0.693} = 9.5 \times 10^{18}$$

$$\therefore 6.023 \times 10^{23} \text{ No. of present in 40 grams.}$$

$$6.023 \times 10^{23} = 40 \text{ g} \Rightarrow 1 = \frac{40}{6.023 \times 10^{23}}$$

$$\therefore 9.5 \times 10^{18} \text{ present in} = \frac{40 \times 9.5 \times 10^{18}}{6.023 \times 10^{23}} = 6.309 \times 10^{-4} = 0.00063.$$

$$\therefore \text{The relative abundance at 40 k in natural potassium} = (2 \times 0.00063 \times 100)\% = 0.12\%.$$

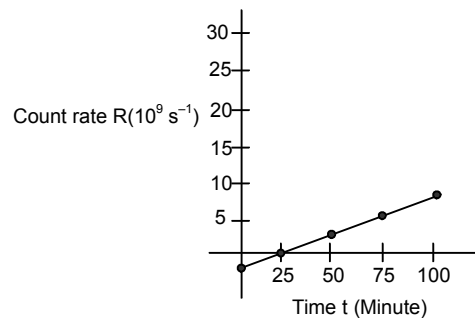

37. a) $P + e \rightarrow n + \nu$ neutrino [a $\rightarrow 4.95 \times 10^7 \text{ s}^{-1/2}$; b $\rightarrow 1$]
 b) $\sqrt{f} = a(z - b)$
 $\Rightarrow \sqrt{c/\lambda} = 4.95 \times 10^7 (79 - 1) = 4.95 \times 10^7 \times 78 \Rightarrow C/\lambda = (4.95 \times 78)^2 \times 10^{14}$
 $\Rightarrow \lambda = \frac{3 \times 10^8}{14903.2 \times 10^{14}} = 2 \times 10^{-5} \times 10^{-6} = 2 \times 10^{-4} \text{ m} = 20 \text{ pm}.$
38. Given : Half life period = $t_{1/2}$, Rate of radio active decay = $\frac{dN}{dt} = R \Rightarrow R = \frac{dN}{dt}$
 Given after time $t \gg t_{1/2}$, the number of active nuclei will become constant.
 i.e. $(\frac{dN}{dt})_{\text{present}} = R = (\frac{dN}{dt})_{\text{decay}}$
 $\therefore R = (\frac{dN}{dt})_{\text{decay}}$
 $\Rightarrow R = \lambda N$ [where, λ = Radioactive decay constant, N = constant number]
 $\Rightarrow R = \frac{0.693}{t_{1/2}} (N) \Rightarrow Rt_{1/2} = 0.693 N \Rightarrow N = \frac{Rt_{1/2}}{0.693}.$
39. Let N_0 = No. of radioactive particle present at time $t = 0$
 N = No. of radio active particle present at time t .
 $\therefore N = N_0 e^{-\lambda t}$ [λ - Radioactive decay constant]
 \therefore The no. of particles decay = $N_0 - N = N_0 - N_0 e^{-\lambda t} = N_0 (1 - e^{-\lambda t})$
 We know, $A_0 = \lambda N_0$; $R = \lambda N_0$; $N_0 = R/\lambda$
 From the above equation
 $N = N_0 (1 - e^{-\lambda t}) = \frac{R}{\lambda} (1 - e^{-\lambda t})$ (substituting the value of N_0)
40. $n = 1 \text{ mole} = 6 \times 10^{23}$ atoms, $t_{1/2} = 14.3$ days
 $t = 70$ hours, dN/dt in root after time $t = \lambda N$
 $N = N_0 e^{-\lambda t} = 6 \times 10^{23} \times e^{\frac{-0.693 \times 70}{14.3 \times 24}} = 6 \times 10^{23} \times 0.868 = 5.209 \times 10^{23}.$
 $5.209 \times 10^{23} \times \frac{-0.693}{14.3 \times 24} = \frac{0.0105 \times 10^{23}}{3600} \text{ dis/hour.}$
 $= 2.9 \times 10^{-6} \times 10^{23} \text{ dis/sec} = 2.9 \times 10^{17} \text{ dis/sec.}$
 Fraction of activity transmitted = $\left(\frac{1 \mu\text{Ci}}{2.9 \times 10^{17}} \right) \times 100\%$
 $\Rightarrow \left(\frac{1 \times 3.7 \times 10^8}{2.9 \times 10^{17}} \times 100 \right) \% = 1.275 \times 10^{-11} \%$.
41. $V = 125 \text{ cm}^3 = 0.125 \text{ L}$, $P = 500 \text{ K pa} = 5 \text{ atm.}$
 $T = 300 \text{ K}$, $t_{1/2} = 12.3 \text{ years} = 3.82 \times 10^8 \text{ sec.}$ Activity = $\lambda \times N$
 $N = n \times 6.023 \times 10^{23} = \frac{5 \times 0.125}{8.2 \times 10^{-2} \times 3 \times 10^2} \times 6.023 \times 10^{23} = 1.5 \times 10^{22} \text{ atoms.}$
 $\lambda = \frac{0.693}{3.82 \times 10^8} = 0.1814 \times 10^{-8} = 1.81 \times 10^{-9} \text{ s}^{-1}$
 Activity = $\lambda N = 1.81 \times 10^{-9} \times 1.5 \times 10^{22} = 2.7 \times 10^3 \text{ disintegration/sec}$
 $= \frac{2.7 \times 10^{13}}{3.7 \times 10^{10}} \text{ Ci} = 729 \text{ Ci.}$
42. ${}_{83}^{212}\text{Bi} \rightarrow {}_{81}^{208}\text{Tl} + {}_2^4\text{He}(\alpha)$
 ${}_{83}^{212}\text{Bi} \rightarrow {}_{84}^{212}\text{Po} + e^-$
 $t_{1/2} = 1 \text{ h.}$ Time elapsed = 1 hour
 at $t = 0$ Bi^{212} Present = 1 g
 \therefore at $t = 1$ Bi^{212} Present = 0.5 g
 Probability α -decay and β -decay are in ratio 7/13.
 \therefore Tl remained = 0.175 g
 \therefore Po remained = 0.325 g

43. Activities of sample containing ^{108}Ag and ^{110}Ag isotopes = 8.0×10^8 disintegration/sec.

a) Here we take $A = 8 \times 10^8$ dis./sec

\therefore i) $\ln(A_1/A_{0_1}) = \ln(11.794/8) = 0.389$

ii) $\ln(A_2/A_{0_2}) = \ln(9.1680/8) = 0.1362$

iii) $\ln(A_3/A_{0_3}) = \ln(7.4492/8) = -0.072$

iv) $\ln(A_4/A_{0_4}) = \ln(6.2684/8) = -0.244$

v) $\ln(5.4115/8) = -0.391$

vi) $\ln(3.0828/8) = -0.954$

vii) $\ln(1.8899/8) = -1.443$

viii) $\ln(1.167/8) = -1.93$

ix) $\ln(0.7212/8) = -2.406$

b) The half life of ^{110}Ag from this part of the plot is 24.4 s.

c) Half life of $^{110}\text{Ag} = 24.4$ s.

\therefore decay constant $\lambda = 0.693/24.4 = 0.0284 \Rightarrow t = 50$ sec,

The activity $A = A_0 e^{-\lambda t} = 8 \times 10^8 \times e^{-0.0284 \times 50} = 1.93 \times 10^8$

d)

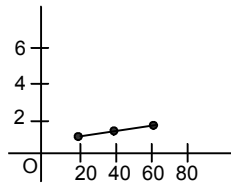

e) The half life period of ^{108}Ag from the graph is 144 s.

44. $t_{1/2} = 24$ h

$\therefore t_{1/2} = \frac{t_1 t_2}{t_1 + t_2} = \frac{24 \times 6}{24 + 6} = 4.8$ h.

$A_0 = 6$ rci ; $A = 3$ rci

$\therefore A = \frac{A_0}{2^{t/t_{1/2}}} \Rightarrow 3 \text{ rci} = \frac{6 \text{ rci}}{2^{t/4.8\text{h}}} \Rightarrow \frac{t}{24.8\text{h}} = 2 \Rightarrow t = 4.8$ h.

45. $Q = qe^{-t/CR}$; $A = A_0 e^{-\lambda t}$

$$\frac{\text{Energy}}{\text{Activity}} = \frac{1q^2 \times e^{-2t/CR}}{2 CA_0 e^{-\lambda t}}$$

Since the term is independent of time, so their coefficients can be equated,

So, $\frac{2t}{CR} = \lambda t$ or, $\lambda = \frac{2}{CR}$ or, $\frac{1}{\tau} = \frac{2}{CR}$ or, $R = 2 \frac{\tau}{C}$ (Proved)

46. $R = 100 \Omega$; $L = 100$ mH

After time t , $i = i_0 (1 - e^{-t/Lr})$ $N = N_0 (e^{-\lambda t})$

$\frac{i}{N} = \frac{i_0(1 - e^{-tR/L})}{N_0 e^{-\lambda t}}$ i/N is constant i.e. independent of time.

Coefficients of t are equal $-R/L = -\lambda \Rightarrow R/L = 0.693/t_{1/2}$

$= t_{1/2} = 0.693 \times 10^{-3} = 6.93 \times 10^{-4}$ sec.

47. 1 g of 'I' contain 0.007 g U^{235} So, 235 g contains 6.023×10^{23} atoms.

So, 0.7 g contains $\frac{6.023 \times 10^{23}}{235} \times 0.007$ atom

1 atom given 200 Mev. So, 0.7 g contains $\frac{6.023 \times 10^{23} \times 0.007 \times 200 \times 10^6 \times 1.6 \times 10^{-19}}{235}$ J = 5.74×10^{-8} J.

48. Let n atoms disintegrate per second

Total energy emitted/sec = $(n \times 200 \times 10^6 \times 1.6 \times 10^{-19})$ J = Power

300 MW = 300×10^6 Watt = Power

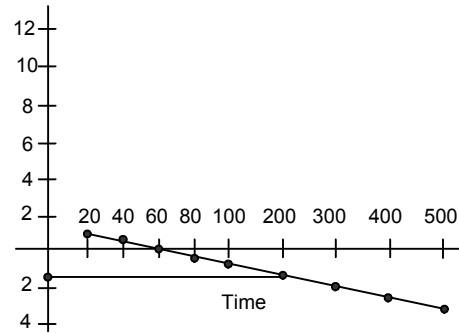

$$300 \times 10^6 = n \times 200 \times 10^6 \times 1.6 \times 10^{-19}$$

$$\Rightarrow n = \frac{3}{2 \times 1.6} \times 10^{19} = \frac{3}{3.2} \times 10^{19}$$

6×10^{23} atoms are present in 238 grams

$$\frac{3}{3.2} \times 10^{19} \text{ atoms are present in } \frac{238 \times 3 \times 10^{19}}{6 \times 10^{23} \times 3.2} = 3.7 \times 10^{-4} \text{ g} = 3.7 \text{ mg.}$$

49. a) Energy radiated per fission = 2×10^8 ev

$$\text{Usable energy} = 2 \times 10^8 \times 25/100 = 5 \times 10^7 \text{ ev} = 5 \times 1.6 \times 10^{-12}$$

$$\text{Total energy needed} = 300 \times 10^8 = 3 \times 10^8 \text{ J/s}$$

$$\text{No. of fission per second} = \frac{3 \times 10^8}{5 \times 1.6 \times 10^{-12}} = 0.375 \times 10^{20}$$

$$\text{No. of fission per day} = 0.375 \times 10^{20} \times 3600 \times 24 = 3.24 \times 10^{24} \text{ fissions.}$$

b) From 'a' No. of atoms disintegrated per day = 3.24×10^{24}

We have, 6.023×10^{23} atoms for 235 g

$$\text{for } 3.24 \times 10^{24} \text{ atom} = \frac{235}{6.023 \times 10^{23}} \times 3.24 \times 10^{24} \text{ g} = 1264 \text{ g/day} = 1.264 \text{ kg/day.}$$

50. a) ${}^2_1\text{H} + {}^2_1\text{H} \rightarrow {}^3_1\text{H} + {}^1_1\text{H}$

$$Q \text{ value} = 2M({}^2_1\text{H}) = [M({}^3_1\text{H}) + M({}^1_1\text{H})]$$

$$= [2 \times 2.014102 - (3.016049 + 1.007825)]u = 4.0275 \text{ Mev} = 4.05 \text{ Mev.}$$

b) ${}^2_1\text{H} + {}^2_1\text{H} \rightarrow {}^3_2\text{He} + n$

$$Q \text{ value} = 2[M({}^2_1\text{H}) - M({}^3_2\text{He}) + M_n]$$

$$= [2 \times 2.014102 - (3.016049 + 1.008665)]u = 3.26 \text{ Mev} = 3.25 \text{ Mev.}$$

c) ${}^2_1\text{H} + {}^3_1\text{H} \rightarrow {}^4_2\text{He} + n$

$$Q \text{ value} = [M({}^2_1\text{H}) + M({}^3_1\text{H}) - M({}^4_2\text{He}) + M_n]$$

$$= (2.014102 + 3.016049) - (4.002603 + 1.008665)]u = 17.58 \text{ Mev} = 17.57 \text{ Mev.}$$

$$51. \text{ PE} = \frac{Kq_1q_2}{r} = \frac{9 \times 10^9 \times (2 \times 1.6 \times 10^{-19})^2}{r} \dots(1)$$

$$1.5 \text{ KT} = 1.5 \times 1.38 \times 10^{-23} \times T \dots(2)$$

$$\text{Equating (1) and (2)} \quad 1.5 \times 1.38 \times 10^{-23} \times T = \frac{9 \times 10^9 \times 10.24 \times 10^{-38}}{2 \times 10^{-15}}$$

$$\Rightarrow T = \frac{9 \times 10^9 \times 10.24 \times 10^{-38}}{2 \times 10^{-15} \times 1.5 \times 1.38 \times 10^{-23}} = 22.26087 \times 10^9 \text{ K} = 2.23 \times 10^{10} \text{ K.}$$

52. ${}^4\text{H} + {}^4\text{H} \rightarrow {}^8\text{Be}$

$$M({}^2\text{H}) \rightarrow 4.0026 \text{ u}$$

$$M({}^8\text{Be}) \rightarrow 8.0053 \text{ u}$$

$$Q \text{ value} = [2 M({}^2\text{H}) - M({}^8\text{Be})] = (2 \times 4.0026 - 8.0053) \text{ u}$$

$$= -0.0001 \text{ u} = -0.0931 \text{ Mev} = -93.1 \text{ Kev.}$$

53. In 18 g of N_0 of molecule = 6.023×10^{23}

$$\text{In 100 g of } N_0 \text{ of molecule} = \frac{6.023 \times 10^{26}}{18} = 3.346 \times 10^{25}$$

$$\therefore \% \text{ of Deuterium} = 3.346 \times 10^{26} \times 99.985$$

$$\text{Energy of Deuterium} = 30.4486 \times 10^{25} = (4.028204 - 3.016044) \times 93$$

$$= 942.32 \text{ ev} = 1507 \times 10^5 \text{ J} = 1507 \text{ mJ}$$



THE SPECIAL THEORY OF RELATIVITY

CHAPTER - 47

1. $S = 1000 \text{ km} = 10^6 \text{ m}$

The process requires minimum possible time if the velocity is maximum.

We know that maximum velocity can be that of light i.e. $= 3 \times 10^8 \text{ m/s}$.

$$\text{So, time} = \frac{\text{Distance}}{\text{Speed}} = \frac{10^6}{3 \times 10^8} = \frac{1}{300} \text{ s.}$$

2. $l = 50 \text{ cm}$, $b = 25 \text{ cm}$, $h = 10 \text{ cm}$, $v = 0.6 c$

a) The observer in the train notices the same value of l , b , h because relativity are in due to difference in frames.

b) In 2 different frames, the component of length parallel to the velocity undergoes contraction but the perpendicular components remain the same. So length which is parallel to the x-axis changes and breadth and height remain the same.

$$e' = e \sqrt{1 - \frac{v^2}{c^2}} = 50 \sqrt{1 - \frac{(0.6)^2 C^2}{C^2}}$$

$$= 50 \sqrt{1 - 0.36} = 50 \times 0.8 = 40 \text{ cm.}$$

The lengths observed are $40 \text{ cm} \times 25 \text{ cm} \times 10 \text{ cm}$.

3. $L = 1 \text{ m}$

a) $v = 3 \times 10^5 \text{ m/s}$

$$L' = 1 \sqrt{1 - \frac{9 \times 10^{10}}{9 \times 10^{16}}} = \sqrt{1 - 10^{-6}} = 0.9999995 \text{ m}$$

b) $v = 3 \times 10^6 \text{ m/s}$

$$L' = 1 \sqrt{1 - \frac{9 \times 10^{12}}{9 \times 10^{16}}} = \sqrt{1 - 10^{-4}} = 0.99995 \text{ m.}$$

c) $v = 3 \times 10^7 \text{ m/s}$

$$L' = 1 \sqrt{1 - \frac{9 \times 10^{14}}{9 \times 10^{16}}} = \sqrt{1 - 10^{-2}} = 0.9949 = 0.995 \text{ m.}$$

4. $v = 0.6 \text{ cm/sec}$; $t = 1 \text{ sec}$

a) length observed by the observer $= vt \Rightarrow 0.6 \times 3 \times 10^8 \Rightarrow 1.8 \times 10^8 \text{ m}$

b) $l = l_0 \sqrt{1 - v^2/c^2} \Rightarrow 1.8 \times 10^8 = l_0 \sqrt{1 - \frac{(0.6)^2 C^2}{C^2}}$

$$l_0 = \frac{1.8 \times 10^8}{0.8} = 2.25 \times 10^8 \text{ m/s.}$$

5. The rectangular field appears to be a square when the length becomes equal to the breadth i.e. 50 m .

i.e. $L' = 50$; $L = 100$; $v = ?$

$C = 3 \times 10^8 \text{ m/s}$

We know, $L' = L \sqrt{1 - v^2/c^2}$

$$\Rightarrow 50 = 100 \sqrt{1 - v^2/c^2} \Rightarrow v = \sqrt{3/2} C = 0.866 C.$$

6. $L_0 = 1000 \text{ km} = 10^6 \text{ m}$

$v = 360 \text{ km/h} = (360 \times 5) / 18 = 100 \text{ m/sec.}$

a) $h' = h_0 \sqrt{1 - v^2/c^2} = 10^6 \sqrt{1 - \left(\frac{100}{3 \times 10^8}\right)^2} = 10^6 \sqrt{1 - \frac{10^4}{9 \times 10^6}} = 10^9.$

Solving change in length = 56 nm .

b) $\Delta t = \Delta L/v = 56 \text{ nm} / 100 \text{ m} = 0.56 \text{ ns}$.

7. $v = 180 \text{ km/hr} = 50 \text{ m/s}$

$t = 10 \text{ hours}$

let the rest dist. be L .

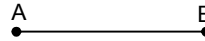

$$L' = L\sqrt{1 - v^2/c^2} \Rightarrow L' = 10 \times 180 = 1800 \text{ k.m.}$$

$$1800 = L\sqrt{1 - \frac{180^2}{(3 \times 10^5)^2}}$$

or, $1800 \times 1800 = L(1 - 36 \times 10^{-14})$

or, $L = \frac{3.24 \times 10^6}{1 - 36 \times 10^{-14}} = 1800 + 25 \times 10^{-12}$

or 25 nm more than 1800 km.

b) Time taken in road frame by Car to cover the dist = $\frac{1.8 \times 10^6 + 25 \times 10^{-9}}{50}$

= $0.36 \times 10^5 + 5 \times 10^{-8} = 10 \text{ hours} + 0.5 \text{ ns.}$

8. a) $u = 5c/13$

$$\Delta t = \frac{t}{\sqrt{1 - v^2/c^2}} = \frac{1y}{\sqrt{1 - \frac{25c^2}{169c^2}}} = \frac{y \times 13}{12} = \frac{13}{12}y.$$

The time interval between the consecutive birthday celebration is 13/12 y.

b) The friend on the earth also calculates the same speed.

9. The birth timings recorded by the station clocks is proper time interval because it is the ground frame. That of the train is improper as it records the time at two different places. The proper time interval ΔT is less than improper.

i.e. $\Delta T' = v \Delta T$

Hence for – (a) up train → Delhi baby is elder (b) down train → Howrah baby is elder.

10. The clocks of a moving frame are out of synchronization. The clock at the rear end leads the one at front by $L_0 v/C^2$ where L_0 is the rest separation between the clocks, and v is speed of the moving frame. Thus, the baby adjacent to the guard cell is elder.

11. $v = 0.9999 C$; $\Delta t = \text{One day in earth}$; $\Delta t' = \text{One day in heaven}$

$$v = \frac{1}{\sqrt{1 - v^2/c^2}} = \frac{1}{\sqrt{1 - \frac{(0.9999)^2 C^2}{C^2}}} = \frac{1}{0.014141782} = 70.712$$

$\Delta t' = v \Delta t$;

Hence, $\Delta t' = 70.7 \text{ days in heaven.}$

12. $t = 100 \text{ years}$; $V = 60/100 C$; $C = 0.6 C$.

$$\Delta t = \frac{t}{\sqrt{1 - V^2/C^2}} = \frac{100y}{\sqrt{1 - \frac{(0.6)^2 C^2}{C^2}}} = \frac{100y}{0.8} = 125 y.$$

13. We know

$$f' = f\sqrt{1 - V^2/C^2}$$

f' = apparent frequency ;

f = frequency in rest frame

$v = 0.8 C$

$$f' = \sqrt{1 - \frac{0.64C^2}{C^2}} = \sqrt{0.36} = 0.6 \text{ s}^{-1}$$

14. $V = 100 \text{ km/h}$, $\Delta t = \text{Proper time interval} = 10 \text{ hours}$

$$\Delta t' = \frac{\Delta t}{\sqrt{1 - V^2/C^2}} = \frac{10 \times 3600}{\sqrt{1 - \left(\frac{1000}{36 \times 3 \times 10^8}\right)^2}}$$

$$\Delta t' - \Delta t = 10 \times 3600 \left[\frac{1}{1 - \left(\frac{1000}{36 \times 3 \times 10^8}\right)^2} - 1 \right]$$

By solving we get, $\Delta t' - \Delta t = 0.154 \text{ ns}$.

\therefore Time will lag by 0.154 ns.

15. Let the volume (initial) be V .

$$V' = V/2$$

$$\text{So, } V/2 = v\sqrt{1 - V^2/C^2}$$

$$\Rightarrow C/2 = \sqrt{C^2 - V^2} \Rightarrow C^2/4 = C^2 - V^2$$

$$\Rightarrow V^2 = C^2 - \frac{C^2}{4} = \frac{3}{4}C^2 \Rightarrow V = \frac{\sqrt{3}}{2}C.$$

16. $d = 1 \text{ cm}$, $v = 0.995 C$

$$\begin{aligned} \text{a) time in Laboratory frame} &= \frac{d}{v} = \frac{1 \times 10^{-2}}{0.995C} \\ &= \frac{1 \times 10^{-2}}{0.995 \times 3 \times 10^8} = 33.5 \times 10^{-12} = 33.5 \text{ PS} \end{aligned}$$

b) In the frame of the particle

$$t' = \frac{t}{\sqrt{1 - V^2/C^2}} = \frac{33.5 \times 10^{-12}}{\sqrt{1 - (0.995)^2}} = 335.41 \text{ PS}.$$

17. $x = 1 \text{ cm} = 1 \times 10^{-2} \text{ m}$; $K = 500 \text{ N/m}$, $m = 200 \text{ g}$
Energy stored = $\frac{1}{2} Kx^2 = \frac{1}{2} \times 500 \times 10^{-4} = 0.025 \text{ J}$

$$\text{Increase in mass} = \frac{0.025}{C^2} = \frac{0.025}{9 \times 10^{16}}$$

$$\text{Fractional Change of max} = \frac{0.025}{9 \times 10^{16}} \times \frac{1}{2 \times 10^{-1}} = 0.01388 \times 10^{-16} = 1.4 \times 10^{-8}.$$

18. $Q = MS \Delta\theta \Rightarrow 1 \times 4200 (100 - 0) = 420000 \text{ J}$.

$$E = (\Delta m)C^2$$

$$\Rightarrow \Delta m = \frac{E}{C^2} = \frac{Q}{C^2} = \frac{420000}{(3 \times 10^8)^2}$$

$$= 4.66 \times 10^{-12} = 4.7 \times 10^{-12} \text{ kg}.$$

19. Energy possessed by a monoatomic gas = $3/2 nRdt$.

Now $dT = 10$, $n = 1 \text{ mole}$, $R = 8.3 \text{ J/mol-K}$.

$$E = 3/2 \times t \times 8.3 \times 10$$

$$\text{Loss in mass} = \frac{1.5 \times 8.3 \times 10}{C^2} = \frac{124.5}{9 \times 10^{15}}$$

$$= 1383 \times 10^{-16} = 1.38 \times 10^{-15} \text{ Kg}.$$

20. Let initial mass be m

$$\frac{1}{2} mv^2 = E$$

$$\Rightarrow E = \frac{1}{2} m \left(\frac{12 \times 5}{18} \right)^2 = \frac{m \times 50}{9}$$

$$\Delta m = E/C^2$$

$$\Rightarrow \Delta m = \frac{m \times 50}{9 \times 9 \times 10^{16}} \Rightarrow \frac{\Delta m}{m} = \frac{50}{81 \times 10^{16}}$$

$$\Rightarrow 0.617 \times 10^{-16} = 6.17 \times 10^{-17}$$

21. Given : Bulb is 100 Watt = 100 J/s

So, 100 J is expended per 1 sec.

Hence total energy expended in 1 year = $100 \times 3600 \times 24 \times 365 = 3153600000$ J

$$\text{Change in mass recorded} = \frac{\text{Total energy}}{C^2} = \frac{3153600000}{9 \times 10^{16}}$$

$$= 3.504 \times 10^8 \times 10^{-16} \text{ kg} = 3.5 \times 10^{-8} \text{ Kg.}$$

22. $I = 1400 \text{ w/m}^2$

$$\text{Power} = 1400 \text{ w/m}^2 \times A$$

$$= (1400 \times 4\pi R^2)w = 1400 \times 4\pi \times (1.5 \times 10^{11})^2$$

$$= 1400 \times 4\pi \times (1/5)^2 \times 10^{22}$$

$$\text{a) } \frac{E}{t} = \frac{\Delta m C^2}{t} = \frac{\Delta m}{t} = \frac{E/t}{C^2}$$

$$C^2 = \frac{1400 \times 4\pi \times 2.25 \times 10^{22}}{9 \times 10^{16}} = 1696 \times 10^{66} = 4.396 \times 10^9 = 4.4 \times 10^9.$$

b) 4.4×10^9 Kg disintegrates in 1 sec.

$$2 \times 10^{30} \text{ Kg disintegrates in } \frac{2 \times 10^{30}}{4.4 \times 10^9} \text{ sec.}$$

$$= \left(\frac{1 \times 10^{21}}{2.2 \times 365 \times 24 \times 3600} \right) = 1.44 \times 10^{-8} \times 10^{21} \text{ y} = 1.44 \times 10^{13} \text{ y.}$$

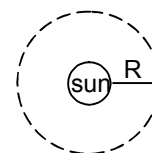

23. Mass of Electron = Mass of positron = 9.1×10^{-31} Kg

Both are oppositely charged and they annihilate each other.

Hence, $\Delta m = m + m = 2 \times 9.1 \times 10^{-31}$ Kg

Energy of the resulting γ particle = $\Delta m C^2$

$$= 2 \times 9.1 \times 10^{-31} \times 9 \times 10^{16} \text{ J} = \frac{2 \times 9.1 \times 9 \times 10^{-15}}{1.6 \times 10^{-19}} \text{ ev}$$

$$= 102.37 \times 10^4 \text{ ev} = 1.02 \times 10^6 \text{ ev} = 1.02 \text{ Mev.}$$

24. $m_e = 9.1 \times 10^{-31}$, $v_0 = 0.8 C$

$$\text{a) } m' = \frac{m_e}{\sqrt{1 - v^2/C^2}} = \frac{9.1 \times 10^{-31}}{\sqrt{1 - 0.64C^2/C^2}} = \frac{9.1 \times 10^{-31}}{0.6}$$

$$= 15.16 \times 10^{-31} \text{ Kg} = 15.2 \times 10^{-31} \text{ Kg.}$$

b) K.E. of the electron : $m'C^2 - m_e C^2 = (m' - m_e) C^2$

$$= (15.2 \times 10^{-31} - 9.1 \times 10^{-31})(3 \times 10^8)^2 = (15.2 \times 9.1) \times 9 \times 10^{-31} \times 10^{18} \text{ J}$$

$$= 54.6 \times 10^{-15} \text{ J} = 5.46 \times 10^{-14} \text{ J} = 5.5 \times 10^{-14} \text{ J.}$$

c) Momentum of the given electron = Apparent mass \times given velocity

$$= 15.2 \times 10^{-31} - 0.8 \times 3 \times 10^8 \text{ m/s} = 36.48 \times 10^{-23} \text{ kg m/s}$$

$$= 3.65 \times 10^{-22} \text{ kg m/s}$$

$$25. \text{ a) } ev - m_0 C^2 = \frac{m_0 C^2}{2\sqrt{1 - \frac{v^2}{C^2}}} \Rightarrow ev - 9.1 \times 10^{-31} \times 9 \times 10^{16}$$

$$= \frac{9.1 \times 9 \times 10^{-31} \times 10^{16}}{2\sqrt{1 - \frac{0.36C^2}{C^2}}} \Rightarrow ev - 9.1 \times 9 \times 10^{-15}$$

$$= \frac{9.1 \times 9 \times 10^{-15}}{2 \times 0.8} \Rightarrow eV - 9.1 \times 9 \times 10^{-15} = \frac{9.1 \times 9 \times 10^{-15}}{1.6}$$

$$\Rightarrow eV = \left(\frac{9.1 \times 9}{1.6} + 9.1 \times 9 \right) \times 10^{-15} = eV \left(\frac{81.9}{1.6} + 81.9 \right) \times 10^{-15}$$

$$eV = 133.0875 \times 10^{-15} \Rightarrow V = 83.179 \times 10^4 = 831 \text{ KV.}$$

$$\text{b) } eV - m_0 C^2 = \frac{m_0 C^2}{2\sqrt{1 - \frac{V^2}{C^2}}} \Rightarrow eV - 9.1 \times 9 \times 10^{-19} \times 9 \times 10^{16} = \frac{9.1 \times 9 \times 10^{-15}}{2\sqrt{1 - \frac{0.81C^2}{C^2}}}$$

$$\Rightarrow eV - 81.9 \times 10^{-15} = \frac{9.1 \times 9 \times 10^{-15}}{2 \times 0.435}$$

$$\Rightarrow eV = 12.237 \times 10^{-15}$$

$$\Rightarrow V = \frac{12.237 \times 10^{-15}}{1.6 \times 10^{-19}} = 76.48 \text{ kV.}$$

$$V = 0.99 C = eV - m_0 C^2 = \frac{m_0 C^2}{2\sqrt{1 - \frac{V^2}{C^2}}}$$

$$\Rightarrow eV = \frac{m_0 C^2}{2\sqrt{1 - \frac{V^2}{C^2}}} + m_0 C^2 = \frac{9.1 \times 10^{-31} \times 9 \times 10^{16}}{2\sqrt{1 - (0.99)^2}} + 9.1 \times 10^{-31} \times 9 \times 10^{16}$$

$$\Rightarrow eV = 372.18 \times 10^{-15} \Rightarrow V = \frac{372.18 \times 20^{-15}}{1.6 \times 10^{-19}} = 272.6 \times 10^4$$

$$\Rightarrow V = 2.726 \times 10^6 = 2.7 \text{ MeV.}$$

$$26. \text{ a) } \frac{m_0 C^2}{\sqrt{1 - \frac{V^2}{C^2}}} - m_0 C^2 = 1.6 \times 10^{-19}$$

$$\Rightarrow m_0 C^2 \left(\frac{1}{\sqrt{1 - V^2/C^2}} - 1 \right) = 1.6 \times 10^{-19}$$

$$\Rightarrow \frac{1}{\sqrt{1 - V^2/C^2}} - 1 = \frac{1.6 \times 10^{-19}}{9.1 \times 10^{-31} \times 9 \times 10^{16}}$$

$$\Rightarrow V = C \times 0.001937231 = 3 \times 0.001967231 \times 0^8 = 5.92 \times 10^5 \text{ m/s.}$$

$$\text{b) } \frac{m_0 C^2}{\sqrt{1 - \frac{V^2}{C^2}}} - m_0 C^2 = 1.6 \times 10^{-19} \times 10 \times 10^3$$

$$\Rightarrow m_0 C^2 \left(\frac{1}{\sqrt{1 - V^2/C^2}} - 1 \right) = 1.6 \times 10^{-15}$$

$$\Rightarrow \frac{1}{\sqrt{1 - V^2/C^2}} - 1 = \frac{1.6 \times 10^{-15}}{9.1 \times 9 \times 10^{15}}$$

$$\Rightarrow V = 0.584475285 \times 10^8 = 5.85 \times 10^7 \text{ m/s.}$$

$$\text{c) } \text{K.E.} = 10 \text{ Mev} = 10 \times 10^6 \text{ eV} = 10^7 \times 1.6 \times 10^{-19} \text{ J} = 1.6 \times 10^{-12} \text{ J}$$

$$\Rightarrow \frac{m_0 C^2}{\sqrt{1 - \frac{V^2}{C^2}}} - m_0 C^2 = 1.6 \times 10^{-12} \text{ J}$$

$$\Rightarrow V^2 = 8.999991359 \times 10^{16} \Rightarrow V = 2.999987038 \times 10^8.$$

27. $\Delta m = m - m_0 = 2m_0 - m_0 = m_0$

Energy $E = m_0 c^2 = 9.1 \times 10^{-31} \times 9 \times 10^{16} \text{ J}$

E in e.v. = $\frac{9.1 \times 9 \times 10^{-15}}{1.6 \times 10^{-19}} = 51.18 \times 10^4 \text{ ev} = 511 \text{ Kev.}$

28.
$$\frac{\left(\frac{m_0 C^2}{\sqrt{1 - \frac{V^2}{C^2}}} - m_0 C^2 \right) - \frac{1}{2} m v^2}{\frac{1}{2} m_0 v^2} = 0.01$$

$$\Rightarrow \left[\frac{m_0 C^2 \left(1 + \frac{V^2}{2C^2} + \frac{1}{2} \times \frac{3}{4} \frac{V^2}{C^2} + \frac{1}{2} \times \frac{3}{4} \times \frac{5}{6} \frac{V^6}{C^6} \right) - m_0 C^2}{\frac{1}{2} m_0 v^2} \right] - \frac{1}{2} m v^2 = 0.1$$

$$\Rightarrow \frac{\frac{1}{2} m_0 v^2 + \frac{3}{8} m_0 \frac{V^4}{C^2} + \frac{15}{96} m_0 \frac{V^4}{C^2} - \frac{1}{2} m_0 v^2}{\frac{1}{2} m_0 v^2} = 0.01$$

$$\Rightarrow \frac{3}{4} \frac{V^4}{C^2} + \frac{15}{96 \times 2} \frac{V^4}{C^4} = 0.01$$

Neglecting the v^4 term as it is very small

$$\Rightarrow \frac{3}{4} \frac{V^2}{C^2} = 0.01 \Rightarrow \frac{V^2}{C^2} = 0.04 / 3$$

$$\Rightarrow V/C = 0.2/\sqrt{3} = V = 0.2/\sqrt{3} C = \frac{0.2}{1.732} \times 3 \times 10^8$$

$$= 0.346 \times 10^8 \text{ m/s} = 3.46 \times 10^7 \text{ m/s.}$$

